

**FAX UNIT**  
**(Machine Code: A639)**

July 31st, 1996  
Subject to change

# Table of Contents

## OVERALL MACHINE INFORMATION

---

|  |            |
|--|------------|
| <b>1.SPECIFICATIONS</b> .....                      | <b>1-1</b> |
| <b>2.FEATURES</b> .....                            | <b>1-2</b> |
| 2.1FEATURES LIST.....                              | 1-2        |
| 2.2CAPABILITIES OF PROGRAMMABLE ITEMS .....        | 1-5        |
| 2.3POSSIBLE COMBINATIONS OF OPTIONAL IC CARDS..... | 1-6        |
| <b>3.OVERALL MACHINE CONTROL</b> .....             | <b>1-7</b> |
| 3.1SYSTEM CONTROL.....                             | 1-7        |
| 3.2POWER DISTRIBUTION AND CONTROL .....            | 1-8        |
| 3.3MEMORY BACK-UP.....                             | 1-8        |
| <b>4.VIDEO DATA PATH</b> .....                     | <b>1-9</b> |
| 4.1TRANSMISSION.....                               | 1-9        |
| 4.2RECEPTION .....                                 | 1-11       |

## DETAILED SECTION DESCRIPTIONS

---

|  |             |
|--|-------------|
| <b>1.AUTOMATIC SERVICE CALLS</b> .....                     | <b>2-1</b>  |
| 1.1SERVICE CALL CONDITIONS.....                            | 2-1         |
| 1.2PERIODIC SERVICE CALL .....                             | 2-3         |
| 1.3PM CALL .....   | 2-3         |
| 1.4EFFECTIVE TERM OF SERVICE CALLS .....                   | 2-3         |
| <b>2.PARALLEL MEMORY TRANSMISSION</b> .....                | <b>2-4</b>  |
| <b>3.TRANSFER BROADCASTING</b> .....                       | <b>2-6</b>  |
| <b>4.ORIGINAL SCAN PROCESS</b> .....                       | <b>2-9</b>  |
| 4.1MAIN SCAN DIRECTION .....                               | 2-9         |
| 4.2SUB SCAN DIRECTION.....                                 | 2-9         |
| <b>5.PAGE SPLIT TRANSMISSION (BOOK TRANSMISSION)</b> ..... | <b>2-10</b> |
| <b>6.IMAGE ROTATION BEFORE TRANSMISSION</b> .....          | <b>2-11</b> |
| <b>7.SMOOTHING</b> .....                                   | <b>2-12</b> |

|   |             |
|---|-------------|
| <b>8.PAPER SIZE SELECTION</b> .....             | <b>2-13</b> |
| 8.1WIDTH PRIORITY AND LENGTH PRIORITY .....     | 2-13        |
| 8.2IMAGE ROTATION BEFORE PRINTING .....         | 2-13        |
| 8.3SUB SCAN REDUCTION AND PAGE SEPARATION ..... | 2-14        |
| 8.4PAGE REDUCTION .....                         | 2-17        |
| 8.5TWO IN ONE .....                             | 2-18        |
| 8.6PAPER SIZE SELECTION PRIORITIES .....        | 2-19        |
| <b>9.TWO-SIDED (DUPLEX) PRINTING</b> .....      | <b>2-25</b> |
| <b>10.PCBs</b> .....                            | <b>2-26</b> |
| 10.1FCU .....                                   | 2-26        |
| 10.2NCU (US) .....                              | 2-28        |
| 10.3NCU (Europe/Asia) .....                     | 2-29        |
| 10.4NCU (France) .....                          | 2-30        |

## **INSTALLATION**

---

|  |             |
|--|-------------|
| <b>1.FAX UNIT</b> .....  | <b>3-1</b>  |
| 1.1INSTALLATION PROCEDURE .....  | 3-1         |
| 1.2INITIAL PROGRAMMING .....   | 3-5         |
| <b>2.ISDN G4 UNIT</b> .....  | <b>3-7</b>  |
| 2.1INSTALLATION PROCEDURE .....  | 3-7         |
| 2.2INITIAL PROGRAMMING .....   | 3-9         |
| <b>3. HARD DISK</b> .....  | <b>3-10</b> |
| 3.1INSTALLATION PROCEDURE .....  | 3-10        |
| 3.2INITIAL PROGRAMMING .....   | 3-11        |
| <b>4.HANDSET</b> .....   | <b>3-12</b> |
| 4.1INSTALLATION PROCEDURE .....  | 3-12        |
| <b>5. IC CARDS</b> .....   | <b>3-13</b> |
| 5.1INSTALLATION PROCEDURE .....  | 3-13        |
| 5.2ITEMS INITIALIZED WHEN FUNCTION UPGRADE CARD IS INSTALLED OR<br>REMOVED ..... | 3-14        |

# SERVICE TABLES AND PROCEDURES

---

|  |            |
|--|------------|
| <b>1.SERVICE LEVEL FUNCTIONS</b> .....             | <b>4-1</b> |
| 1.1HOW TO ENTER AND EXIT THE FAX SERVICE MODE..... | 4-1        |
| 1.2BIT SWITCH PROGRAMMING (FUNCTION 01).....       | 4-1        |
| 1.3SYSTEM PARAMETER LISTS (FUNCTION 02).....       | 4-2        |
| 1.4ROM VERSION DISPLAY (FUNCTION 02).....          | 4-5        |
| 1.5ERROR CODE DISPLAY (FUNCTION 03).....           | 4-5        |
| 1.6SERVICE MONITOR REPORT (FUNCTION 04).....       | 4-5        |
| 1.7G3 PROTOCOL DUMP LIST (FUNCTION 05).....        | 4-5        |
| 1.8G4 PROTOCOL DUMP LIST (FUNCTION 05).....        | 4-5        |
| 1.9RAM DISPLAY AND REWRITE (FUNCTION 06).....      | 4-6        |
| 1.10NCU PARAMETERS (FUNCTION 06).....              | 4-6        |
| 1.11RAM DUMP (FUNCTION 06).....                    | 4-7        |
| 1.12RAM CLEAR (FUNCTION 07).....                   | 4-7        |
| 1.13HARD DISK (FUNCTION 08).....                   | 4-8        |
| 1.14SERVICE STATION FAX NUMBER (FUNCTION 09).....  | 4-8        |
| 1.15SERIAL NUMBER (FUNCTION 10).....               | 4-9        |
| 1.16MODEM TEST (FUNCTION 11).....                  | 4-9        |
| 1.17DTMF TEST (FUNCTION 11).....                   | 4-9        |
| 1.18MODEM SIGNAL DETECTION TEST (FUNCTION 11)..... | 4-10       |
| 1.19RINGER TEST (FUNCTION 11).....                 | 4-10       |
| 1.20STAMP TEST .....                               | 4-10       |
| 1.21G4 PARAMETER PROGRAMMING (FUNCTION 12).....    | 4-11       |
| 1.22FILE PRINTOUT (FUNCTION 13).....               | 4-11       |
| 1.23TCR/JOURNAL PRINTOUT (FUNCTION 14).....        | 4-11       |
| 1.24USAGE LOG PRINTOUT (FUNCTION 15).....          | 4-12       |
| 1.25SOFTWARE DOWNLOAD (FUNCTION 16).....           | 4-13       |
| 1.26SOFTWARE UPLOAD (FUNCTION 16).....             | 4-15       |
| 1.27SRAM DATA DOWNLOAD (FUNCTION 16).....          | 4-16       |

|  |             |
|--|-------------|
| <b>2.BIT SWITCHES</b> .....                      | <b>4-18</b> |
| 2.1SYSTEM SWITCHES .....                         | 4-18        |
| 2.2SCANNER SWITCHES .....                        | 4-30        |
| 2.3PRINTER SWITCHES.....                         | 4-35        |
| 2.4COMMUNICATION SWITCHES.....                   | 4-40        |
| 2.5G3 SWITCHES .....                             | 4-47        |
| <b>3.NCU PARAMETERS</b> .....                    | <b>4-54</b> |
| <b>4.DEDICATED TRANSMISSION PARAMETERS</b> ..... | <b>4-63</b> |
| 4.1PROGRAMMING PROCEDURE .....                   | 4-63        |
| 4.2PARAMETERS .....                              | 4-64        |
| <b>5.SERVICE RAM ADDRESSES</b> .....             | <b>4-67</b> |
| <b>6.SPECIAL TOOLS AND LUBRICANTS</b> .....      | <b>4-77</b> |

## **REMOVAL AND REPLACEMENT**

---

|                           |            |
|---------------------------|------------|
| <b>1.PRECAUTION</b> ..... | <b>5-1</b> |
| <b>2.NCU</b> .....        | <b>5-2</b> |
| <b>3.FCU</b> .....        | <b>5-3</b> |

## **TROUBLESHOOTING**

---

|                             |            |
|-----------------------------|------------|
| <b>1.ERROR CODES</b> .....  | <b>6-1</b> |
| <b>2.FAX SC CODES</b> ..... | <b>6-7</b> |
| 2.1SC1201 .....             | 6-7        |
| 2.2SC1701 .....             | 6-7        |
| 2.3FAX SC CODE TABLE .....  | 6-8        |

**SECTION 1**

**OVERALL MACHINE  
INFORMATION**

# 1. SPECIFICATIONS

## Type

Desktop type transceiver

## Circuit

PSTN, PABX, ISDN (optional)

## Connection

Direct couple

## Original Size (Book)

### Maximum Length:

432 mm

### Maximum Width:

297 mm

## Original Size (ADF)

### Length:

105 - 1200 mm [4.1 - 47.2 ins]

### Width:

105 - 297 mm [4.1 - 11.7 ins]

### Thickness:

0.05 to 0.2 mm [2 to 8 mils]  
(equivalent to 40 - 90 g/m<sup>2</sup>)

## Note:

The maximum original length varies in immediate tx mode, depending on the scan width and resolution.

Refer to the "Video Data Path" later in this chapter for more details.

## Scanning Method

Flat bed, with CCD

## Scan Width

210 mm [8.64 ins] ± 1% (A4)

216 mm [8.5 ins] ± 1% (8.5" x 11")

256 mm [10.2 ins] ± 1% (B4)

279 mm [11.0 ins] ± 1% (11" x 17"r)

296 mm [12.2 ins] ± 1% (A3)

## Resolutions

8 x 3.85 lines/mm

8 x 7.7 lines/mm

8 x 15.4 lines/mm (G3 only)

16 x 15.4 lines/mm

200 x 100 dpi

200 x 200 dpi

400 x 400 dpi

## Note:

To use the 8 x 15.4 lines/mm, 16 x 15.4 lines/mm and 400 x 400 dpi resolutions, an optional page memory card is required.

## Memory Capacity

**ECM:** 128 kbytes

## SAF:

**Standard: 1 Mbytes:** 73 pages

**With 2 Mbyte option:** 219 pages

**With 4 Mbyte option:** 365 pages

**With 80 Mbyte HDD option:** 1200 pages

**With 80 Mbyte HDD plus Function**

**Upgrade Card:** 3000 pages

Measured using an ITU-T #1 test document (Slerexe letter)

## Compression

MH, MR, EFC, MMR, SSC (MMR only with ECM and G4)

SAF storage for memory tx: MMR and raw data

## Protocol

Group 3 with ECM

Group 4 (ISDN G4 option required)

## Modulation

V.17(TCM), V.29 (QAM), V.27ter (PHM), V.21 (FM)

## Data Rate (bps)

**G3:** 14400/12000/9600/7200/4800/2400, Automatic fallback

**G4 (option):** 64 kbps/56 kbps

## I/O Rate

With ECM: 0 ms/line

Without ECM: 2.5, 5, 10, 20, or 40 ms/line

## Transmission Time

**G3:** 6 s at 14400 bps; Measured with G3 ECM using memory for an ITU-T #1 test document (Slerexe letter) at 8 x 3.85 l/mm resolution

**G4 (option):** 3 s at 64 kbps; Measured with an ITU-T #1 test document (Slerexe letter) at 200 x 200 dpi resolution

## 2. FEATURES

### 2.1 FEATURES LIST

KEY:

O = Used, X = Not Used,

A = Optional memory 2M/4M required

B = Optional hard disk required

C = Optional page memory required

D = Optional function upgrade card required

E = Optional G4 kit required

| Video Processing Features                |   |
|--|---|
| Automatic image density selection        | O |
| Contrast                                 | O |
| Halftone (Basic & Error Diffusion)       | O |
| MTF                                      | O |
| Reduction before tx (B4 -> A4)           | O |
| Reduction before tx (A3 -> B4)           | O |
| Reduction before tx (A3 -> A4)           | O |
| Scanning Resolution - Standard           | O |
| Scanning Resolution - Detail             | O |
| Scanning Resolution - Fine               | C |
| Scanning Resolution - Superfine          | C |
| Smoothing to 400 x 400 dpi when printing | O |

| Communication Features - Automatic   |        |
|--------------------------------------|--------|
| AI short protocol                    | O      |
| Automatic fallback                   | O      |
| Automatic redialing (Memory tx only) | O      |
| Confidential reception               | A or B |
| Dual Access                          | O      |
| Substitute reception                 | O      |

| Communication Features - User Selectable |        |
|--|--------|
| 90° Image Rotation before tx             | O      |
| Action as a transfer broadcaster         | A or B |
| AI Redial (last ten numbers)             | O      |
| Answering machine interface              | X      |
| Authorized Reception                     | O      |
| Auto-answer delay time                   | X      |

| Communication Features - User Selectable |        |
|--|--------|
| Automatic dialing (pulse or DTMF)        | O      |
| Auto Document                            | O      |
| Automatic Voice Message                  | X      |
| Batch Transmission                       | A or B |
| Book Original tx                         | O      |
| Broadcasting                             | O      |
| Chain Dialing                            | O      |
| Communication Record Display             | O      |
| Confidential ID Override                 | O      |
| Confidential Reception                   | A or B |
| Confidential Transmission                | O      |
| Direct Fax Number Entry                  | O      |
| Economy Transmission                     | A or B |
| Fax on demand                            | X      |
| Forwarding                               | A or B |
| Free Polling                             | O      |
| Groups (9 groups)                        | O      |
| Group Transfer Station                   | A or B |
| Hold                                     | X      |
| ID Transmission                          | O      |
| Immediate Redialing                      | O      |
| Immediate transmission                   | O      |
| Keystroke Programs                       | O      |
| Length Reduction                         | O      |
| Memory transmission                      | O      |
| Multi-step Transfer                      | A or B |
| Next Transfer Station                    | X      |
| Non-standard original size specification | O      |
| OMR                                      | X      |
| On Hook Dial                             | O      |
| Ordering Toner                           | X      |
| Page Count                               | O      |
| Page separation mark                     | O      |
| Parallel memory transmission             | O      |
| Personal Codes                           | O      |
| Personal Codes with Conf. ID             | X      |
| Partial Image Area Scanning              | X      |
| Polling Reception                        | O      |
| Polling Transmission                     | O      |
| Polling tx file lifetime in the SAF      | O      |
| Quick Dial (Standard: 56 stations)       | O      |



| <b>Communication Features - User Selectable</b> |   |
|---|---|
| Reception modes (Fax, Tel)                      | O |
| Remote control features                         | X |
| Remote Transfer                                 | X |
| Resolutions available for reception             |   |
| Standard  | O |
| Detail  | O |
| Fine (16 x 15.4 l/mm only)                      | C |
| Superfine                                       | C |
| Restricted Access                               | O |
| Secured Polling                                 | O |
| Secured Polling with Stored ID Override         | O |
| Secure Transmission                             | X |
| Send Later                                      | O |
| Silent ringing detection                        | X |
| Speed Dial<br>(Standard: 100 stations)          | O |
| Telephone Directory                             | O |
| Tonal Signal Transmission                       | O |
| Transfer Request                                | O |
| Transmission Deadline (TRD)                     | O |
| Turnaround Polling                              | X |
| Two-step Transfer                               | X |
| Two in one                                      | O |
| Voice Request (immed. tx only)                  | X |

| <b>Communication Features - Service Selectable</b> |   |
|--|---|
| AI Short Protocol                                  | O |
| Auto-reduction override option                     | O |
| Busy tone detection                                | O |
| Cable Equalizer                                    |   |
| PSTN   | O |
| ISDN   | E |
| Closed Network (rx)                                | O |
| Continuous Polling Reception                       | O |
| Dedicated tx parameters                            | O |
| ECM  | O |
| EFC  | O |
| Inch-mm conversion before tx                       | O |
| mm-inch selection when printing                    | O |
| Page retransmission times                          | O |
| Protection against wrong conn.                     | O |
| Resol'n stepdown override option                   | X |
| Short Preamble                                     | X |
| Well log   | O |

| <b>Other User Features</b>                  |         |
|---|---------|
| Area code prefix                            | X       |
| Center mark                                 | O       |
| Checkered mark                              | O       |
| Clearing a memory file                      | O       |
| Clearing a polling file                     | O       |
| Clock                                       | O       |
| Confidential ID                             | A or B  |
| Counters                                    | O       |
| Daylight Saving Time                        | O       |
| Destination Check                           | X       |
| Direct entry of names                       | O       |
| File Retention Time                         | O       |
| File Retransmission                         | O       |
| Function Programs (F1 - F4)                 | O       |
| Hard Disk Filing System                     | X       |
| ID Code                                     | O       |
| Label Insertion ("To xxx")                  | O       |
| Language Selection                          | SP mode |
| Manual service call                         | O       |
| Memory Lock                                 | A or B  |
| Modifying a memory file (tx)                | O       |
| Multi Sort Document Reception               | A or B  |
| Own telephone number                        | O       |
| Energy Saver (Night Timer and standby mode) | O       |
| Print density control                       | O       |
| Printing a memory file                      | O       |
| RDS on/off                                  | O       |
| Reception Mode Switching Timer              | X       |
| Reception time printing                     | O       |
| Remaining memory indicator                  | O       |
| Reverse Order Printing                      | A or B  |
| RTI, TTI, CSI                               | O       |
| Speaker volume control                      | O       |
| Specified Cassette Selection                | O       |
| Substitute reception on/off                 | O       |
| Telephone line type                         | O       |
| Toner Saving Mode                           | X       |
| TTI/CIL on/off                              | O       |
| User Function Keys (4 keys)                 | O       |
| User Parameters                             | O       |
| Wild Cards                                  | O       |

| <b>Reports - Automatic</b>   |        |
|------------------------------|--------|
| Charge Control Report        | X      |
| Communication Failure Report | O      |
| Confidential File Report     | A or B |
| Error Report                 | O      |
| Fax On Demand Report         | X      |
| Memory Storage Report        | O      |
| Mode Change Report           | X      |
| Polling Clear Report         | O      |
| Polling Reserve Report       | O      |
| Polling Result Report        | O      |
| Power Failure Report         | O      |
| TCR (Journal)                | O      |
| Toner Cassette Order Form    | X      |
| Transfer Result Report       | A or B |
| Transmission Result Report   | O      |

| <b>Reports - User-initiated</b>   |        |
|-----------------------------------|--------|
| Authorized Reception List         | O      |
| Charge Control Report             | X      |
| File List                         | O      |
| Forwarding List                   | A or B |
| Group List                        | O      |
| Hard Disk File List               | X      |
| Personal Code List                | O      |
| Program List                      | O      |
| Quick Dial List                   | O      |
| Specified Cassette Selection List | B      |
| Speed Dial List                   | O      |
| TCR                               | O      |
| Transmission Status Report        | X      |
| User Function List                | X      |
| User Parameter List               | O      |

| <b>Service Mode Features</b>                      |         |
|---|---------|
| File Transfer                                     | O       |
| Hard Disk Utilities (Format etc.)                 | B       |
| LCD contrast adjustment                           | SP mode |
| Line error mark                                   | O       |
| Memory file printout (all files)                  | O       |
| Modem test  | O       |
| NCU parameters                                    | O       |
| Periodic service call                             | O       |
| PM Call   | O       |
| Printing all communication records kept in memory | O       |
| Programmable attenuation                          | X       |
| Protocol dump list                                | O       |
| RAM display/rewrite                               | O       |
| RAM dump  | O       |
| RAM test  | O       |
| RDS   |         |
| - RAM read/write                                  | O       |
| - Dial data transfer (Quick/Speed)                | O       |
| - Software transfer                               | O       |
| Ringer test                                       | O       |
| ROM version display                               | O       |
| Serial number                                     | O       |
| Service monitor report                            | O       |
| Service station number                            | O       |
| Software Download                                 | O       |
| Software Upload                                   | O       |
| SRAM data download                                | O       |
| System parameter list                             | O       |
| Technical data on the TCR                         | O       |

| <b>Service Mode Features</b>    |   |
|---------------------------------|---|
| Back-to-back test               | O |
| Bit switch programming          | O |
| Buzzer test                     | O |
| Cable equalizer                 | O |
| Comm. parameter display         | O |
| Counter check                   | O |
| Country code                    | O |
| DTMF tone test                  | O |
| Echo countermeasure             | O |
| Effective term of service calls | O |
| Error code display              | O |
| Excessive jam alarm             | O |

## 2.2 CAPABILITIES OF PROGRAMMABLE ITEMS

The following table shows how the capabilities of each programmable item will change after the optional function upgrade card is installed.

| Item   | Standard                                 | With function upgrade card               |
|--|--|--|
| Maximum number of memory files plus polling rx files   | 200                                      | 1000                                     |
| Maximum number of memory files   | 200                                      | 1000                                     |
| Maximum number of destinations per file  | 200                                      | 200                                      |
| Maximum number of destinations overall   | 500                                      | 2000                                     |
| Maximum number of pages overall  | 1200                                     | 3000                                     |
| Number of Quick Dials  | 56                                       | 56                                       |
| Number of Speed Dials  | 100                                      | 1000                                     |
| Number of Groups   | 9  | 30                                       |
| Maximum number of destinations per Group   | 200                                      | 200                                      |
| Maximum number of destinations dialed from the ten-key pad overall   | 100                                      | 1000                                     |
| Maximum number of programs   | 56<br>(programmed in 56 Quick Dial keys) | 56<br>(programmed in 56 Quick Dial keys) |
| Maximum number of destinations per program   | 200                                      | 200                                      |
| Maximum number of destinations used for all programs   | 300                                      | 2000                                     |
| Maximum number of Auto Documents   | 6<br>(programmed in 6 Quick Dial keys)   | 18<br>(programmed in 18 keys)            |
| Maximum number of communication records for the TCR (Journal) stored in the memory                               | 256                                      | 1000                                     |
| Maximum number of addresses specified for features such as Authorized Reception and Specified Cassette Selection | 30                                       | 50                                       |
| Maximum number of personal codes   | 20                                       | 50                                       |

Overall  
Machine  
Information

## 2.3 POSSIBLE COMBINATIONS OF OPTIONAL IC CARDS

The following table shows which optional IC cards can be or cannot be installed at the same time.

"**Yes**" in the table indicates that these two optional IC cards can be installed at the same time.

"**No**" in the table indicates that these two optional IC cards cannot be installed at the same time.

|   | <b>A</b>   | <b>B</b>   | <b>C</b>   | <b>D</b>   | <b>E</b>   |
|---|------------|------------|------------|------------|------------|
| <b>A:</b> Feature Expander 2M/4M                      |            | <b>No</b>  | <b>Yes</b> | <b>Yes</b> | <b>Yes</b> |
| <b>B:</b> Feature Expander 80M (HDD)                  | <b>No</b>  |            | <b>Yes</b> | <b>Yes</b> | <b>Yes</b> |
| <b>C:</b> Function Upgrade Card                       | <b>Yes</b> | <b>Yes</b> |            | <b>Yes</b> | <b>No</b>  |
| <b>D:</b> Page Memory Card                            | <b>Yes</b> | <b>Yes</b> | <b>Yes</b> |            | <b>Yes</b> |
| <b>E:</b> Flash/SRAM Data Copy Tool<br>(Service Tool) | <b>Yes</b> | <b>Yes</b> | <b>No</b>  | <b>Yes</b> |            |

# 3. OVERALL MACHINE CONTROL

## 3.1 SYSTEM CONTROL

Overall Machine Information

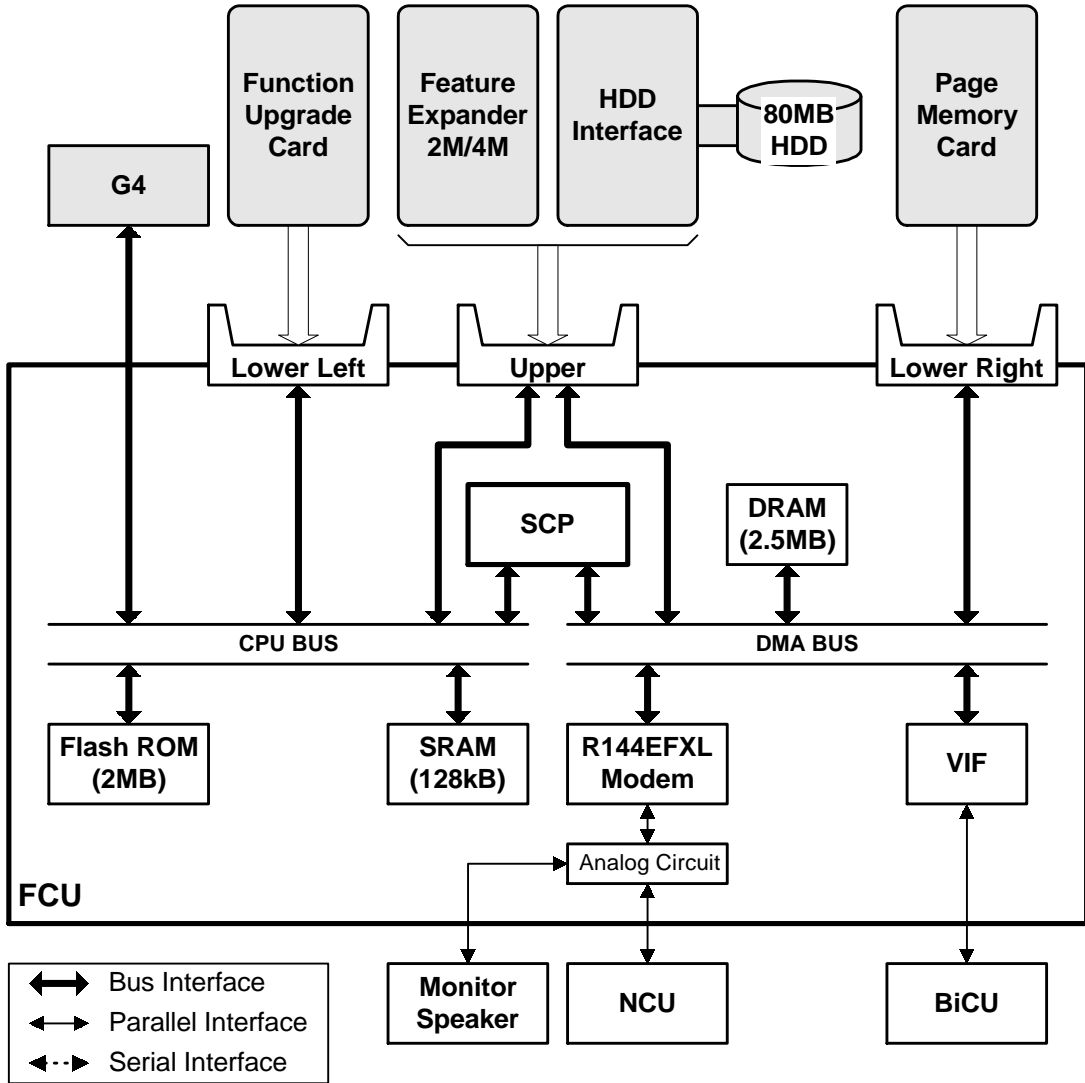

A194V500.wmf

The basic Fax Unit consists of two PCBs: an FCU and an NCU.

The FCU controls all the fax communications and fax features, in cooperation with the base copier's main board, the BiCU. The NCU switches the analog line between the fax unit and the optional external telephone.

### **Fax Options**

1. G4 unit: This allows the Fax Unit to communicate over an ISDN (Integrated Services Digital Network) line.
2. Function Upgrade Card: This expands the system's SRAM capacity to hold programmed telephone numbers, communication records, etc.
3. Feature Expander - 2M/4M: This expands the DRAM's capacity to hold up to 3MB or 5MB of received data or data for transmission. Also, some additional features become available when the Feature Expander is installed.
4. Feature Expander - Hard Disk: This extends the image data capacity to 80MB. Also, some additional features become available when the Feature Expander is installed.
5. Page Memory Card (High Resolution Card): This enhances the scan and receive resolutions to up to 400 x 400 dpi. Without this card, only 'Standard' and 'Detail' resolutions are available for both transmission and reception.

## **3.2 POWER DISTRIBUTION AND CONTROL**

The FCU is supplied from the base copier's BiCU (+24V, +12V, -12V, and +5VE) and PSU (+5V). Refer to the base copier's service manual for details.

## **3.3 MEMORY BACK-UP**

The system parameters and programmed items in the SRAM on the FCU and the SRAM on the Function Upgrade Card are backed up by a battery (long-term backup), in case the the base copier's ac switch is turned off.

**Note:** The data in the SRAM is not guaranteed if the card is disconnected from the machine. Whenever the Function Upgrade Card needs to be removed, follow the instructions in the software upload and download procedures in the Service Level Functions section to avoid any data loss.

The SAF memory DRAM on the FCU and the Feature Expander Card are backed up by a rechargeable battery for 1-hour.

# 4. VIDEO DATA PATH

## 4.1 TRANSMISSION

Overall Machine Information

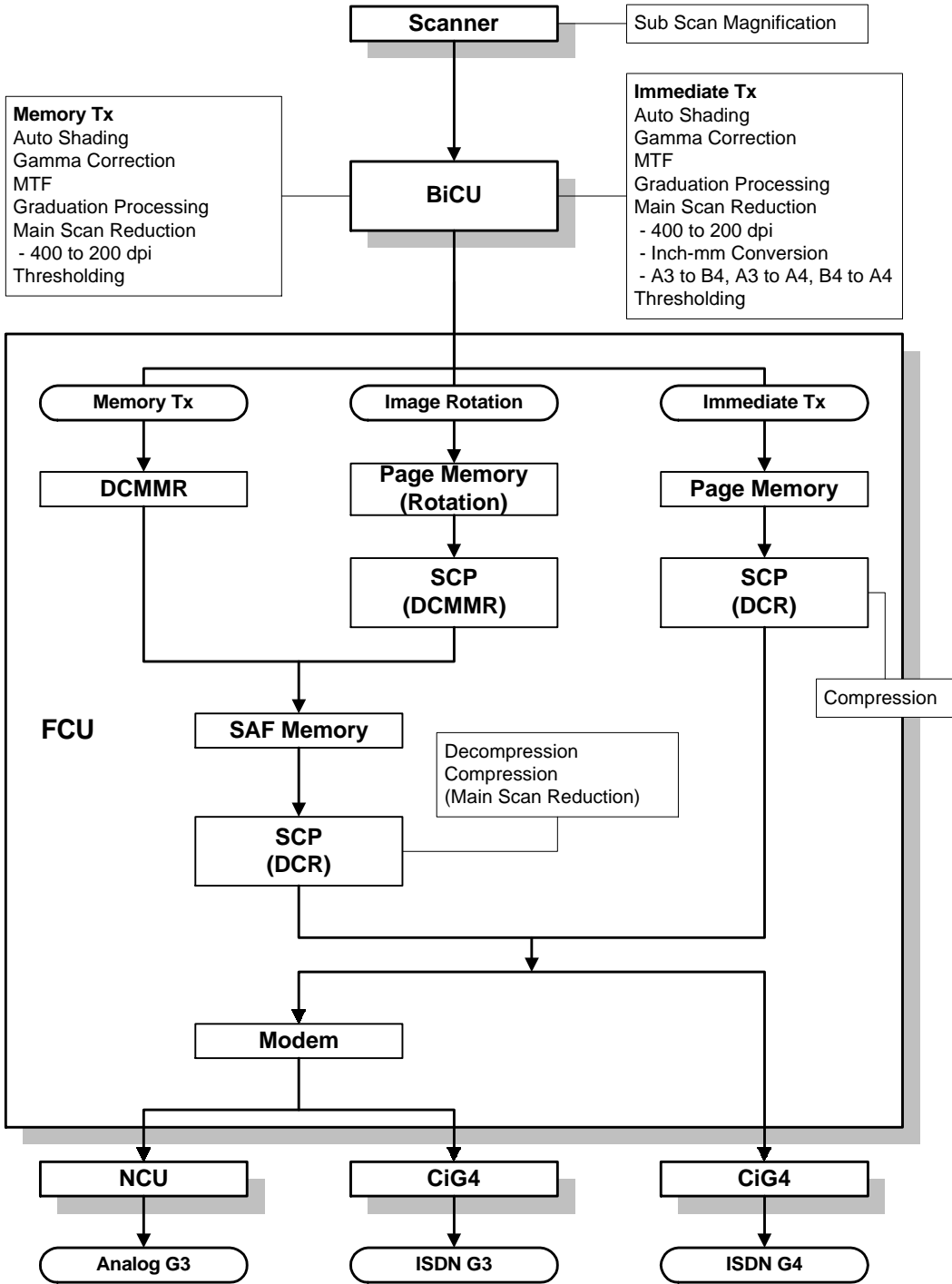

A194V501.wmf



## Memory Transmission and Parallel Memory Transmission

The base copier's scanner scans the original at the selected resolution in inch format. The BiCU processes the data and transfers it to the FCU.

**Note** When scanning a fax original, the BiCU uses the MTF and Thresholding parameter settings programmed in the scanner bit switches, not the copier's SP modes.

Then, the FCU converts the data to mm format, and compresses the data in MMR+raw format to store it in the SAF memory. If image rotation is possible, the image is rotated in page memory before compression.

At the time of transmission, the FCU decompresses the stored data, then re-compresses and/or reduces the data if necessary for transmission. Either the NCU or CiG4 (optional) transmits the data to the line.

### Immediate Transmission

The base copier's scanner scans the original at the resolution agreed with the receiving terminal. The BiCU video processes the data and transfers it to the FCU.

**Note** When scanning a fax original, the BiCU uses the MTF and Thresholding parameter settings programmed in the scanner bit switches, not the copier's SP modes.

Then the FCU stores the data in page memory, and compresses the data for transmission. Either the NCU or CiG4 (optional) transmits the data to the line.

The maximum transmittable page size for immediate transmission varies depending on the resolution selected and the size of page memory available. This is because the scanned data is stored in the page memory before transmission, not the SAF memory. Refer to the following table for details.

| Width                 | Resolution | Without optional Page Memory card | With optional Page Memory card |
|-----------------------|------------|-----------------------------------|--------------------------------|
| A4 (210 mm)/<br>8.5"  | Standard   | 1200 mm (47.2")                   | 1200 mm (47.2")                |
|                       | Detail     | 600 mm (23.6")                    | 1200 mm (47.2")                |
|                       | Fine       | Not usable                        | 1200 mm (47.2")                |
|                       | Superfine  | Not usable                        | 600 mm (23.6")                 |
| B4 (256 mm)/<br>10.1" | Standard   | 1000 mm (39.4")                   | 1200 mm (47.2")                |
|                       | Detail     | 500 mm (19.7")                    | 1200 mm (47.2")                |
|                       | Fine       | Not usable                        | 1000 mm (47.2")                |
|                       | Superfine  | Not usable                        | 500 mm (19.7")                 |
| A3 (297 mm)/<br>11"   | Standard   | 800 mm (31.5")                    | 1200 mm (47.2")                |
|                       | Detail     | 432 mm (17.0")                    | 1200 mm (47.2")                |
|                       | Fine       | Not usable                        | 800 mm (31.5")                 |
|                       | Superfine  | Not usable                        | 432 mm (17.0")                 |



## 4.2 RECEPTION

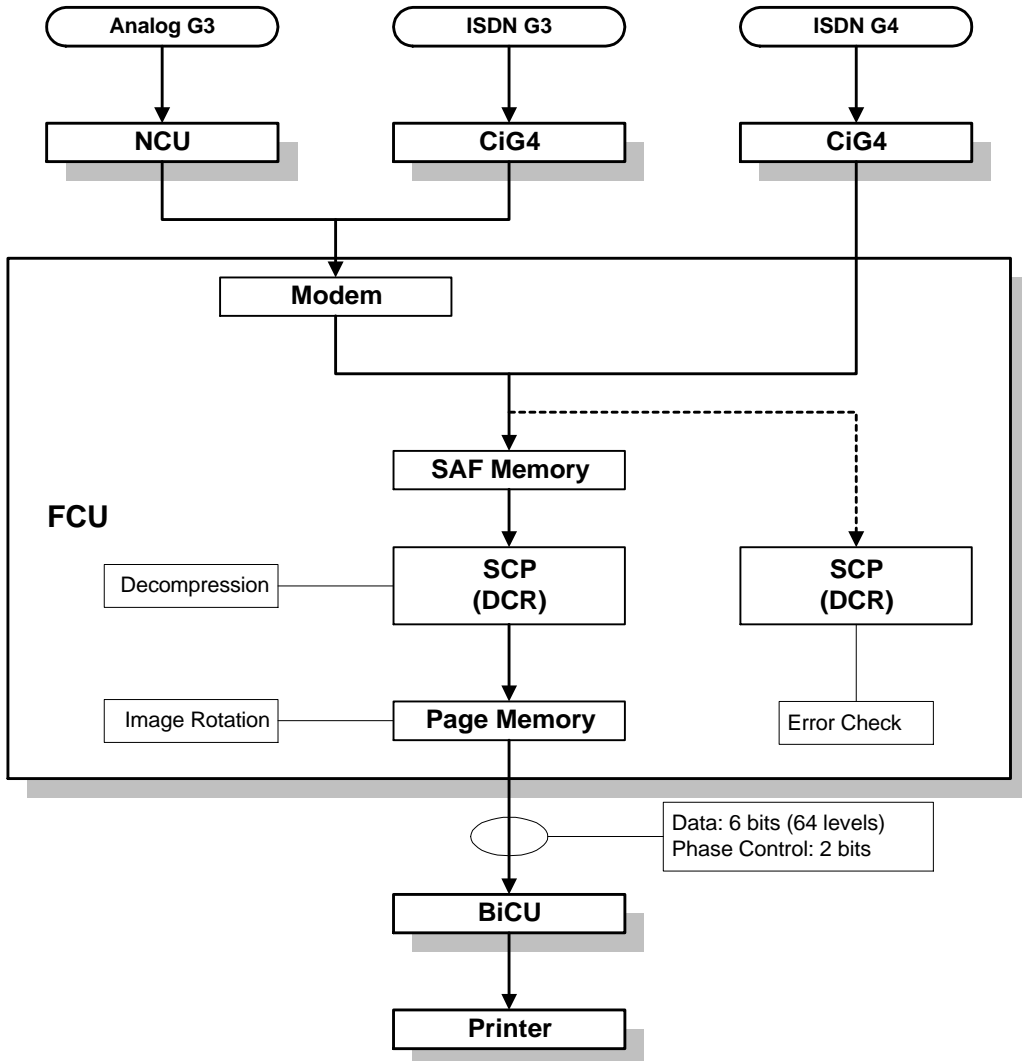

Overall Machine Information

A194V502.wmf

First, the FCU stores the data from either an analog line or an ISDN line to the SAF memory. (The data goes in parallel to the SCP, and is checked for error lines/frames.)

The FCU then decompresses the data and transfers it to page memory. If image rotation is possible, the image is rotated in page memory. The data is transferred to the BiCU in the 8-bit format (6-bits level/2-bits phase) used by the base copier's laser engine for printing.

**SECTION 2**

**DETAILED SECTION**  
**DESCRIPTIONS**

# 1. AUTOMATIC SERVICE CALLS

## 1.1 SERVICE CALL CONDITIONS

The fax unit makes an automatic service call when an SC code, other than the following, is informed from the base copier's BiCU.

**Note** The service station's fax number has to be programmed in advance, for the machine to make a service call.

### Exceptions

| Address (H) | Definition                     | Default | SC code                         |
|-------------|--------------------------------|---------|---------------------------------|
| 49FB64      | 1st SC code - High byte (BCD)  | 01      | 192                             |
| 49FB65      | 1st SC code - Low byte (BCD)   | 92      | SBU adjustment error            |
| 49FB66      | 2nd SC code - High byte (BCD)  | 01      | 193                             |
| 49FB67      | 2nd SC code - Low byte (BCD)   | 93      | APS sensor error                |
| 49FB68      | 3rd SC code - High byte (BCD)  | 03      | 390                             |
| 49FB69      | 3rd SC code - Low byte (BCD)   | 90      | TD sensor error 1               |
| 49FB6A      | 4th SC code - High byte (BCD)  | 03      | 393                             |
| 49FB6B      | 4th SC code - Low byte (BCD)   | 93      | TD sensor error 2               |
| 49FB6C      | 5th SC code - High byte (BCD)  | 06      | 691                             |
| 49FB6D      | 5th SC code - Low byte (BCD)   | 91      | BiCU/FCU<br>communication error |
| 49FB6E      | 6th SC code - High byte (BCD)  | 09      | 980                             |
| 49FB6F      | 6th SC code - Low byte (BCD)   | 80      | BiCU program load error         |
| 49FB70      | 7th SC code - High byte (BCD)  | FF      | Not programmed                  |
| 49FB71      | 7th SC code - Low byte (BCD)   | FF      |                                 |
| 49FB72      | 8th SC code - High byte (BCD)  | FF      | Not programmed                  |
| 49FB73      | 8th SC code - Low byte (BCD)   | FF      |                                 |
| 49FB74      | 9th SC code - High byte (BCD)  | FF      | Not programmed                  |
| 49FB75      | 9th SC code - Low byte (BCD)   | FF      |                                 |
| 49FB76      | 10th SC code - High byte (BCD) | FF      | Not programmed                  |
| 49FB77      | 10th SC code - Low byte (BCD)  | FF      |                                 |

Detailed  
Section  
Descriptions

To add additional SC codes, program them in the blank addresses.

The fax unit cannot make an automatic service call when a Fax SC code condition has occurred. Refer to Troubleshooting for Fax SC code details.

### Manual Service Call

If the service station needs a report, the user can make a service call manually, by setting bit 7 of User Parameter 14 (0E) to '1'.

A Sample Auto Service Report Format

```

* * * Auto Service Report (Date and Time) * * *

Problem      Reason of the call - "SC Code" or "PM Call"
S C          Latest 10 copier's SC codes
J A M       BJ A M 2FEED SIZE005      0708
    
```

Last 4 digits of the total print counter  
 Paper Size Code  
 Paper Feed Station  
 Jam Location

Service Monitor Report Contents

System Parameter List Contents

A194D508.wmf

| Paper Size Code Table |               |      |                       |
|-----------------------|---------------|------|-----------------------|
| Code                  | Size          | Code | Size                  |
| 005                   | A4 sideways   | 038  | 8.5 x 11" sideways    |
| 006                   | A5 sideways   | 044  | 5.5 x 8.5" sideways   |
| 014                   | B5 sideways   | 160  | 11 x 17" lengthwise   |
| 031                   | Non-standard  | 164  | 8.5 x 14" lengthwise  |
| 132                   | A3 lengthwise | 166  | 8.5 x 11" lengthwise  |
| 133                   | A4 lengthwise | 172  | 5.5 x 8.5" lengthwise |
| 141                   | B4 lengthwise |      |                       |
| 142                   | B5 lengthwise |      |                       |
| 159                   | Non-standard  |      |                       |

## 1.2 PERIODIC SERVICE CALL

The periodic service call notifies the service station of the machine's condition. The call is made at a time interval programmed in the following RAM addresses:

| Parameters  | Address (H) |
|---|-------------|
| Call interval: 01 through 15 month(s) (BCD)<br>00: Periodic Service Call Disabled | 480379      |
| Date and time of the next call  |             |
| Year: last two digits of the year (BCD)   | 48037A      |
| Month: 01 through 12 (BCD)  | 48037B      |
| Day: 01 through 31 (BCD)  | 48037C      |
| Hour: 00 through 23 (BCD)   | 48037D      |

Detailed  
Section  
Descriptions

To change these settings after programming, change the call interval. The machine then automatically changes the remaining parameters by referring to the interval and the current date and time.

## 1.3 PM CALL

If PM alarm is enabled by the base copier's SP mode and PM call is enabled by system switch 01, the machine will make an automatic service call when the base copier's PM counter reaches the PM interval.

### Cross reference

PM service call on/off: System switch 01, bit 0

PM alarm on/off: SP mode 5-501-2 (default: enabled)

PM interval: SP mode 5-501-1 (default: 45k prints)

## 1.4 EFFECTIVE TERM OF SERVICE CALLS

If a time limit for the effectiveness of service calls is programmed, the machine stops making automatic service calls after the time limit.

Program the time limit at the following addresses. This function is disabled when all of these addresses are 00(H).

|   | Address (H) |
|---|-------------|
| Year: last two digits of the year (BCD) | 480383      |
| Month: 01 through 12 (BCD)              | 480384      |
| Day: 01 through 31 (BCD)                | 480385      |

## 2. PARALLEL MEMORY TRANSMISSION

Using basic memory transmission, normally the machine starts dialing after the document has been completely scanned. Using Parallel Memory Transmission, the machine starts dialing at the same time the machine starts scanning. If the document has multiple pages, the machine scans them into memory and sends them while scanning continues.

**Note** This function is only usable when sending an original from the ADF.

The following table shows the differences between normal memory transmission and parallel memory transmission.

|  | Normal memory tx   | Parallel memory tx  |
|--|--|---|
| File Reserve Report                                    | Printed, if automatic report printout is enabled.  | Not printed.  |
| If the other terminal is busy                          | Tries to resend the message later.   | Continues scanning the document into memory, and tries to resend it later.  |
| If transmission failed                                 | Tries to resend the remaining pages later.   | Tries to resend the remaining pages later.  |
| If memory overflows during scanning                    | Stops scanning and erases all the scanned pages from memory, or sends all the scanned pages (user's choice). | Stops scanning and hangs up the communication when memory overflow is detected. Then erases all the scanned pages from memory without notifying the user. |
| If a document jam occurred during scanning             | Stops scanning and deletes all the scanned pages from memory.  | Stops scanning and hangs up the communication when a document jam is detected.  |
| How and when the scanned message is erased from memory | The complete message is erased after all the pages have been sent.   | Same as memory transmission.  |
| Memory threshold to start scanning into memory         | Depends on the setting of communication switch 0D. Default setting - 24kB                                    | Depends on the setting of system switch 10. Default setting - 512 kB  |
| Meaning of the stamp mark                              | Successfully stored.   | Successfully stored.  |
| Batch numbering (P. x/x)                               | Enabled  | Not available unless the number of pages is programmed manually.  |
| Including a sample of the image on reports             | Possible   | Possible  |

In the following cases, the machine uses normal memory transmission even if parallel memory transmission is enabled.

- Send later transmission
- Broadcasting
- Transmission of an Auto Document only
- Transfer request transmission
- When Image Rotation before Tx is enabled, and an A4 sideways or 8.5 x 11" sideways original is detected
- If the other terminal is busy
- If the external telephone connected to the machine is in use
- When communication switch 0A, bit 0 is set to 1, and the machine is using memory transmission when redialing
- When remaining memory space is less than the threshold for parallel memory transmission (default = 512 kB)
- When the original is located on the exposure glass

When using G4 transmission, parallel memory transmission is normally disabled, because transmission using G4 is much faster than scanning. As a result, G4 transmission using parallel memory transmission takes about twice as long as normal memory transmission (using an ITU-T #1 test chart).

If the document contains pages with complicated images or it is a photo document using halftone, parallel memory transmission may be faster than normal memory transmission. If the user commonly sends this type of fax message, enable parallel memory transmission for G4 transmission by changing system switch 11, bit 7 to 1.

### Cross Reference

|   |                                  |
|---|----------------------------------|
| Parallel memory tx (G3) On/Off                            | - User parameter 07, bit 2       |
| Parallel memory tx (G4) On/Off                            | - System switch 11, bit 7        |
| Memory threshold for enabling parallel memory tx          | - System switch 10, bits 0 to 7  |
| Point of resumption of memory transmission upon redialing | - Communication switch 0A, bit 0 |

### 3. TRANSFER BROADCASTING

This machine uses a new algorithm to identify the requester's fax number to send back the transfer result report. Previously, the transfer result report did not sometimes reach the requester with the old algorithm.

In a transfer broadcasting operation, the transfer requester informs its own fax number to the transfer station. The transfer station uses that number to identify the requester's fax number, which the transfer station must dial to send the transfer result report back to the requester.

Transmission of the transfer result report and selection of the number to dial depends on the following three settings.

| Setting   | Switch   |
|---|--|
| Conditions required for transfer result report transmission   | Communication switch 0B, bit 3<br>0: Always<br>1: Only if there is an error            |
| Action when there is no fax number in the programmed Quick/Speed dials which matches the requester's own fax number | Communication switch 0B, bit 5<br>0: Transfer is cancelled<br>1: Transfer is continued |
| Number of digits compared to find the requester's fax number from the programmed Quick/Speed dials.                 | Communication switch 0C, bits 0 to 4<br>(default setting = 5 digits)                   |

The requester's fax number format is normally as follows.

[ International access code ] [ Country code ] [ Area code ] - [ Local tel. no.]  
A pause ("-") must be programmed between area code and local tel. no.

Before the machine transfers the message, the machine compares the last few digits of the requester's own fax number with all the programmed Quick/Speed Dials as shown in the following diagram. Starting from Quick Dial 01 to the end of the Speed Dial codes. (The default setting for the number of digits compared is 5; see the above table.)

If the machine finds a number in which the compared digits match those of the requester's own fax number, the machine chooses the number as the destination for sending the report back. However, depending on the number of digits compared, the machine may choose the wrong destination, as shown in the example diagram on the next page.

Note that the machine does not compare the following:

- Pause ("-")
- ISDN sub-address ("/aaaa", "aaaa" is a sub-address number)

With a G4 transfer request, the G4 and G3 own fax numbers are informed from the requester, then the machine compares the G4 number first, and the G3 number second.



**Example**

**Requester's Own Fax No.  
0111201-2223456**

| No. of digits to compare | Result   |
|--------------------------|----------|
| 4                        | Q01      |
| 5                        | Q05      |
| 6                        | Q05      |
| 7                        | Q05      |
| 8                        | Q08      |
| 9                        | Q08      |
| 10                       | Q08      |
| 11                       | S07      |
| 12                       | No match |
| 13                       | No match |

|     |                  |
|-----|------------------|
| Q01 | 071-441-3456     |
| Q02 | 020-4773456      |
| Q03 | 020-4776666      |
| Q04 | 00-81454771748   |
| Q05 | 2223456          |
| Q06 | 00-4961969063456 |
| Q07 | 0569723456       |
| Q08 | 201-2223456      |
| Q09 | 00-31204564569   |
| Q10 | 013453456        |
| ⋮   | ⋮                |
| Q56 | 0875558888       |

|     |                 |
|-----|-----------------|
| S00 | 1223456         |
| S01 | 5413654         |
| S02 | 00-4126567878   |
| S03 | 0454771748      |
| S04 | 0634558989      |
| S05 | 07474125899     |
| S06 | 00-85226356541  |
| S07 | 00-12012223456  |
| S08 | 02212301564     |
| S09 | 6524555         |
| ⋮   | ⋮               |
| S99 | 00-496158756452 |

|      |            |
|------|------------|
| S100 | 2223456    |
| ⋮    | ⋮          |
| S999 | 0454771759 |

With  
Function Upgrade Card

A194D501.wmf

**Detailed  
Section  
Descriptions**

In this example:

Transfer Requester: USA (international dial access code 011)

Transfer Station: UK (international dial access code 00)

In the above example:

- If the requester is within the same area, Quick Dial 05 or Quick Dial 08 is the correct destination, depending on the required dialing method for numbers in the same country or area. The machine selects Quick Dial 05 if it compares from 5 to 7 digits, and selects Quick Dial 08 if it compares from 8 to 10 digits.
- If the requester is in another country, Speed Dial 07 is the correct destination. The machine selects this number if it compares 11 digits. Any setting higher than this will result in no match, due to the different international access codes at the start of the numbers.
- If the machine compares less than 4 digits, it selects Quick Dial 01.
- If the number of digits to compare is set to zero, the machine sends the report to the first Quick or Speed Dial number programmed in.

Note that the result can be changed depending on the locations where the candidates are programmed. For example, if "00-1-2012223456" is programmed in Quick Dial 01, the machine always selects this number for sending back the report, even if the transfer request is from within the same country.

When programming the machine to act as a Transfer Station, the combination of the communication switch 0C setting (number of digits) and the programmed location of the requester's fax number has to be considered carefully.

If the machine can not find the destination for the report, it either:

- Stops the transfer operation and prints a report locally (if bit 5 of communication switch 0B is 0).
- Or, continues the transfer operation and prints a result report locally after finishing all the transfer operations (if bit 5 of communication switch 0B is 1).

### **Cross Reference to other parameters**

|   |                                  |
|---|----------------------------------|
| ID code programming   | - Key operator mode              |
| Use of economy transmission during a transfer operation to end receivers          | - Communication switch 0B, bit 0 |
| Use of economy transmission during a transfer operation to next transfer stations | - Communication switch 0B, bit 1 |
| Use of label insertion for the end receivers in a transfer operation              | - Communication switch 0B, bit 2 |
| Printout of the message when acting as a transfer station                         | - Communication switch 0B, bit 4 |

## 4. ORIGINAL SCAN PROCESS

The machine scans at 400 dpi. The other end may have a different paper size or may not be able to print at 400 dpi. The base copier's scanner and BiCU work together to get the required resolution and size for transmission.

### 4.1 MAIN SCAN DIRECTION

The base copier's scanner always scans at 400 dpi (main scan direction). Then, the BiCU processes the scanned data to get the required resolution and data width. This is the same process as Reduction in copy mode.

**dpi:** dots per inch, **dpm:** dots per mm

| Reduction    | 400 dpi | 200 dpi | 16 dpm | 8 dpm |
|--------------|---------|---------|--------|-------|
| No reduction | 100.0%  | 50.0%   | 101.5% | 51.0% |
| A3 to B4     | 86.5%   | 43.0%   | 88.0%  | 44.0% |
| A3 to A4     | 70.5%   | 35.0%   | 71.5%  | 36.0% |
| B4 to A4     | 81.5%   | 41.0%   | 83.0%  | 41.5% |

Detailed  
Section  
Descriptions

### 4.2 SUB SCAN DIRECTION

In the sub scan direction, the base machine's scanner changes the motor speed to get the required resolution. However, if the reduction rate requires a faster speed than the scanner motor's maximum (37% reduction rate when using the ADF), the scanner and the BiCU (IPU) work together to get the required resolution as shown in the second table below.

| Reduction    | 400 lpi | 200 lpi            | 100 lpm            | 15.4 lpm | 7.7 lpm            | 3.85 lpm            |
|--------------|---------|--------------------|--------------------|----------|--------------------|---------------------|
| No reduction | 100.0%  | 50.0%              | 25.0% <sup>2</sup> | 97.8%    | 48.9%              | 24.5% <sup>7</sup>  |
| A3 to B4     | 86.5%   | 43.2%              | 21.6% <sup>3</sup> | 84.6%    | 42.3%              | 21.2% <sup>8</sup>  |
| A3 to A4     | 70.5%   | 35.2% <sup>1</sup> | 17.6% <sup>4</sup> | 69.0%    | 34.5% <sup>6</sup> | 17.3% <sup>9</sup>  |
| B4 to A4     | 81.5%   | 40.8%              | 20.4% <sup>5</sup> | 79.7%    | 39.8%              | 19.9% <sup>10</sup> |

**lpi:** lines per inch, **lpm:** lines per mm

| Notes           | Mode | Reduction by Scanner | Reduction by BiCU |
|-----------------|------|----------------------|-------------------|
| Case 1 (35.2%)  |      | 52.8%                | 66.7%             |
| Case 2 (25.0%)  | ADF  | 50.0%                | 50.0%             |
|                 | Book | 25.0%                |                   |
| Case 3 (21.6%)  |      | 43.2%                | 50.0%             |
| Case 4 (17.6%)  |      | 52.8%                | 33.3%             |
| Case 5 (20.4%)  |      | 40.8%                | 50.0%             |
| Case 6 (34.5%)  |      | 51.9%                | 66.7%             |
| Case 7 (24.5%)  | ADF  | 48.9%                | 50.0%             |
|                 | Book | 36.8%                | 66.7%             |
| Case 8 (21.2%)  |      | 42.4%                | 50.0%             |
| Case 9 (17.3%)  |      | 51.9%                | 33.3%             |
| Case 10 (19.9%) |      | 39.8%                | 50.0%             |

## 5. PAGE SPLIT TRANSMISSION (BOOK TRANSMISSION)

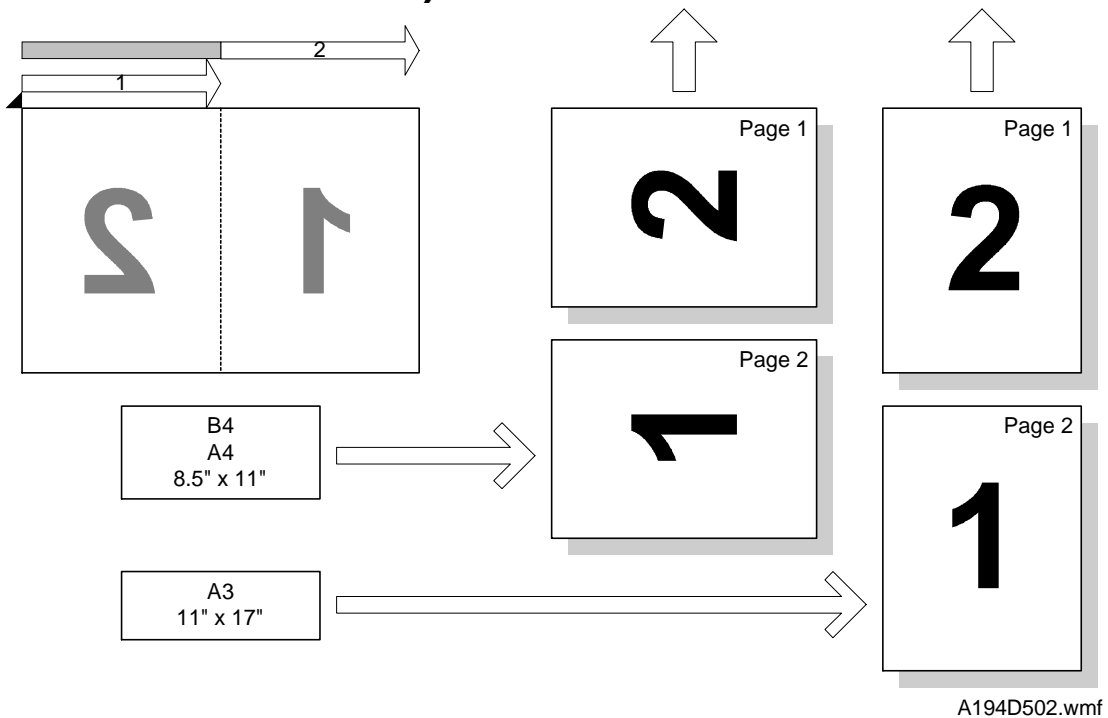

This function allows a B4, A4/8.5 x 11", or A3/11 x 17" size book original to be sent on two separate pages.

When this function is selected, the machine scans the original twice, and transmits the scanned pages in the same sequence as the pages were scanned.

In the above example, the page with number '2' is sent first, and the page with number '1' is sent next. To send page '1' first, the original should be placed so that page '1' is at the left.

- Notes**
- Memory transmission is used whenever this function is selected.
  - This function is only possible when sending a book original from the exposure glass.
  - If this function is used for an A3 or 11 x 17" original, the pages may be transmitted in a lengthwise direction, depending on the setting of "Image Rotation before Transmission" (see the next page).

## 6. IMAGE ROTATION BEFORE TRANSMISSION

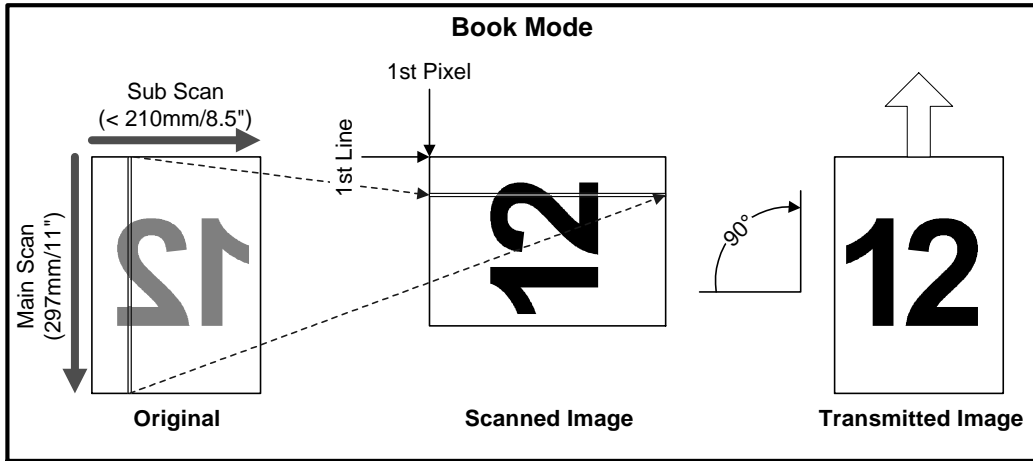
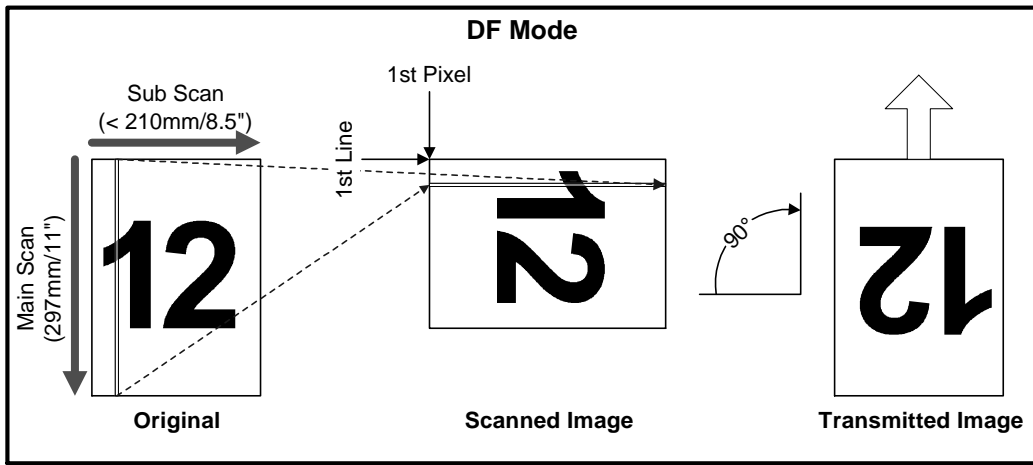

A194D503.wmf

This function avoids the unintentional reduction of an A3 or 11" width original. When the machine detects an A4 or 8.5 x 11" original placed sideways in the ADF or on the exposure glass, the fax unit rotates the scanned image clockwise by 90 degrees before transmission, as shown above.

- Notes**
- The orientations of the transmitted image from the ADF and from the exposure glass are different.
  - Even if Parallel Memory Transmission is enabled, the machine uses normal memory transmission to send an A4 or 8.5 x 11" sideways original.
  - If the machine carries out this function while printing, the machine stops printing until scanning is completed.

### Cross Reference

Image rotation before tx on/off - Scanner switch 0F, bit 0

## 7. SMOOTHING

When the fax unit prints a received fax image, the FCU converts the data into 400 x 400 dpi, 16 x 15.4 l/mm, or 15.4 x 16 l/mm (image rotation) resolution, and smooths the image. The FCU then sends the smoothed data to the printer in the 64 gradation levels + 3 laser pulse positions format used by the base copier.

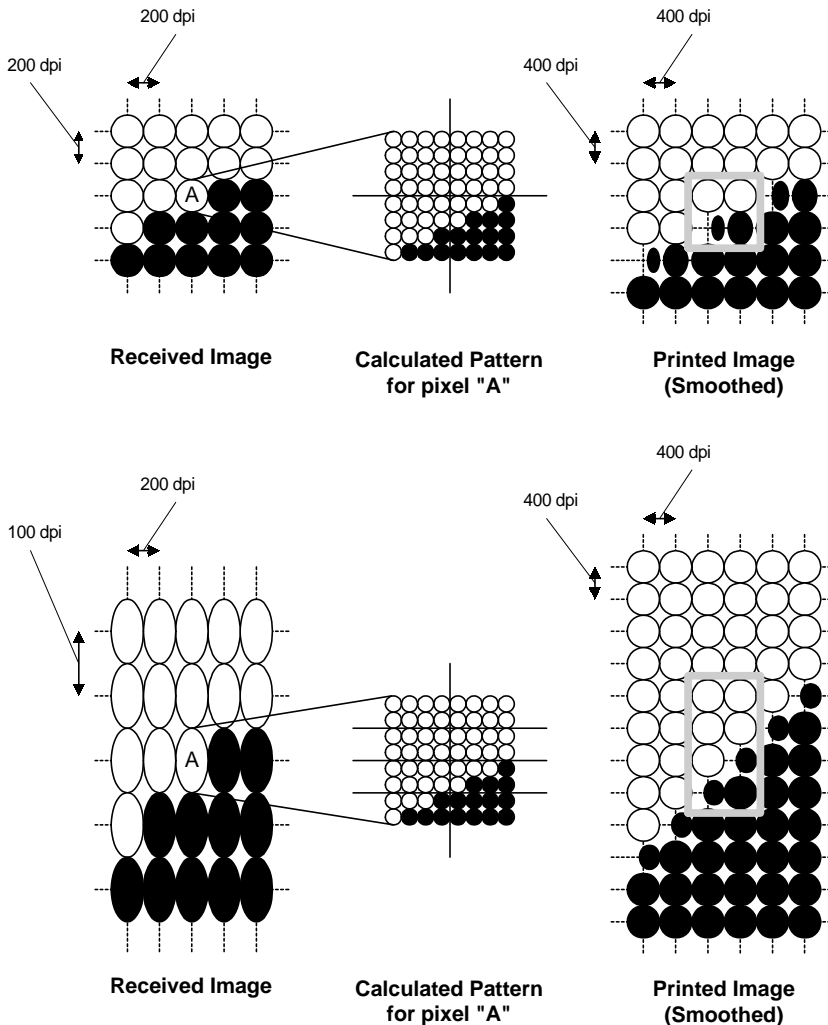

A194D504.wmf

**Note** The FCU does not smooth the received data in the following instances:

- Halftone data is received in NSF mode
- The data is received at 400 x 400 dpi or 16 x 15.4 l/mm resolution.
- When image rotation is done, if the received data is at 200 x 100 dpi, 200 x 200 dpi, 8 x 3.85 l/mm, or 8 x 7.7 l/mm.

---

## 8. PAPER SIZE SELECTION

This section explains how the FCU selects the appropriate paper size for printing a received fax image. Refer to the 'Paper Size Selection Priorities' tables at the end of this section for how the appropriate paper size is actually selected.

### 8.1 WIDTH PRIORITY AND LENGTH PRIORITY

When 'Width Priority' is selected, a paper size of the same width as the received fax image has a higher priority. The fax image may be printed on several pages.

When 'Length Priority' is selected, a paper size which has enough length to print the received fax image has higher priority. The fax image is printed on one sheet of paper, but the printed fax may have wide margins on the left and right.

#### Cross Reference

Paper selection priority - Printer switch 0E, bit 0 (Default: Width)

### 8.2 IMAGE ROTATION BEFORE PRINTING

If the machine has the same size of paper in a cassette as the received fax image size, but in the sideways orientation, the fax unit rotates the image by 90 degrees clockwise, and prints it on sideways paper.

This feature is only possible when the received fax image is one of the following sizes: A4 lengthwise, 8.5 x 11" lengthwise, B5 lengthwise

**Note** This function cannot be disabled.

### 8.3 SUB SCAN REDUCTION AND PAGE SEPARATION

#### Sub Scan Reduction Disabled

When Sub Scan Reduction is disabled, the received fax image is printed unreduced.

If the image is longer than the paper length + 6 mm, the image is separated onto two pages (see the top drawing below).

If the image is shorter than the paper length + 6 mm but longer than the paper length - 4 mm, the part of the image after paper length - 4 mm will be lost (see the bottom drawing below).

**Note** The page separation threshold is adjustable between 0 and 15 mm (the default is paper length + 6 mm). Refer to Printer Switch 03, bits 4 to 7 for more details.

The 2 mm gaps at the leading and trailing edges depend on the leading and trailing edge margin settings.

The 10 mm image duplication can be adjusted or disabled.

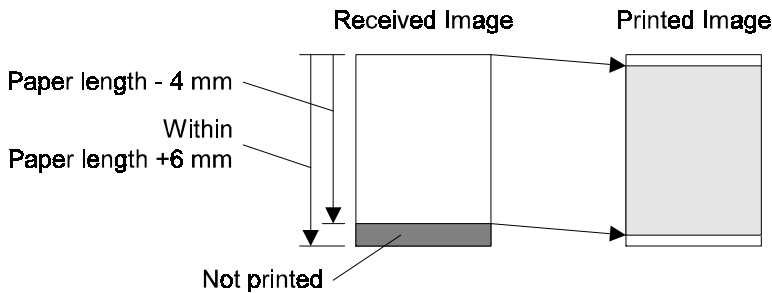
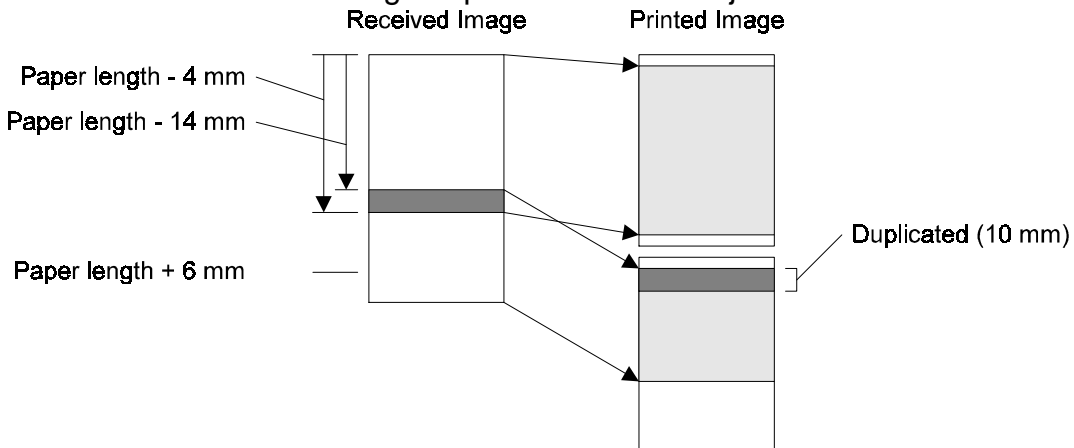

A194D505.wmf



### Sub Scan Reduction Enabled

When Sub Scan Reduction is enabled, the received fax image is reduced in the page memory to fit on the selected paper, if the received image length is between [paper length - 4 mm] and [paper length + 20 mm]. See the drawing below.

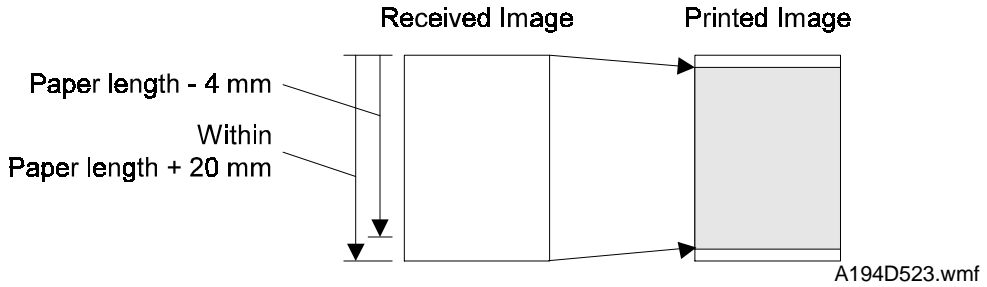

**Note** The upper limit (page length + 20 mm) is adjustable between 0 and 155 mm. Refer to Printer Switch 04, bits 0 to 4 for more details.

If the FCU detects that the image must be separated into more than one page after reduction, what happens to the data depends on the Reduction Rate Equalization setting (Printer Switch 0E, bit 7).

#### - Reduction Rate Equalization Off (Example Diagram: Two-page Printout) -

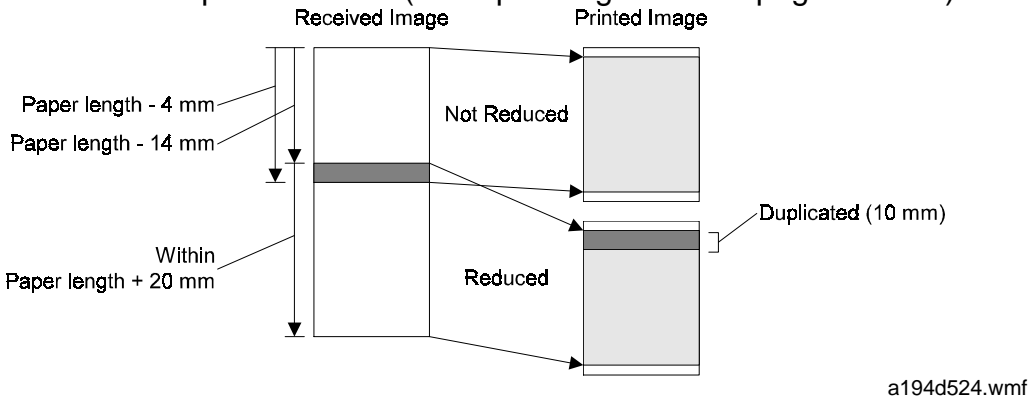

1. The data up to [page length - 4 mm] will be printed on page 1, without reduction.
2. The last 10 mm of this data will be repeated at the top of the next page (this length can be adjusted or repetition can be switched off).
3. The remaining data will be printed on page 2, with reduction, if it is within [paper length + 20 mm].
4. If it is longer than this, page separation is done again. Data up to [page length - 4 mm] will be printed on page 2, without reduction.
5. The process for page 3 and subsequent pages will repeat from step 2.

Detailed Section Descriptions

- Reduction Rate Equalization On (Example Diagram: Two-page Printout) -

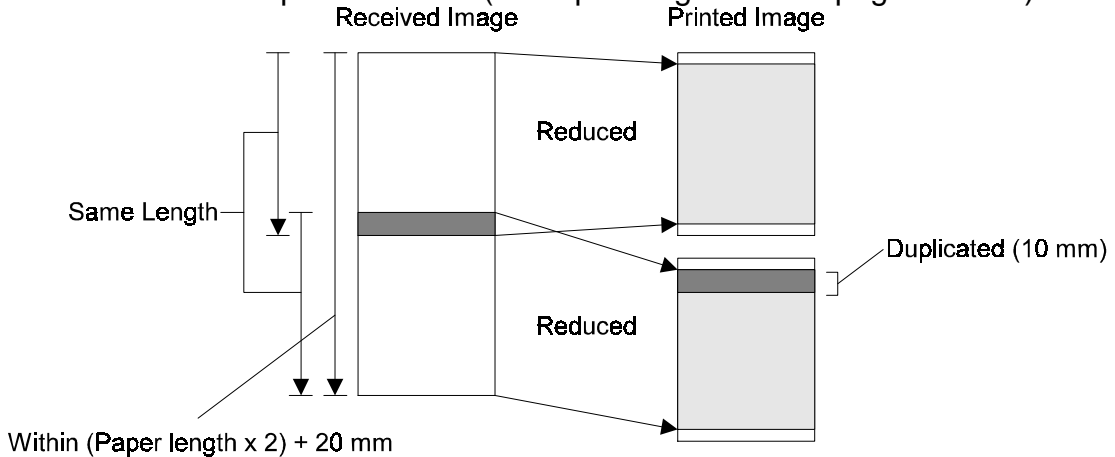

1. The machine determines how many pages will be needed to print the message, taking the following into account:  
 The final page (n) is such that the received image length is within (paper length x n) + 20 mm  
 The data must be reduced to fit on pages of length (paper length - 4 mm), with an equal reduction rate for each page  
 The last 10 mm of the previous page will be repeated at the top of the next page (this length can be adjusted or repetition can be disabled).
2. The machine prints all the pages, at the same reduction rate.

If the customer does not want to receive a fax message on separate pages, page separation can be disabled. However, once it has been disabled, the machine does not print the received fax message until a paper size which can hold the received fax image on one page is set in a cassette. Keep page separation enabled if the customer expects to receive a fax message that is longer than the copy paper.

**Cross Reference**

| Parameter  | Switch                      | Default Setting          |
|--|-----------------------------|--------------------------|
| Reduction in sub-scan direction on/off               | Printer Switch 03, bit 0    | Enabled (except Germany) |
| Equalizing reduction rate among separated pages      | Printer Switch 0E, bit 7    | Enabled                  |
| Page separation threshold when reduction is disabled | Printer Switch 03, bits 4-7 | 6 mm                     |
| Page separation threshold when reduction is enabled  | Printer Switch 04, bits 0-4 | 20 mm                    |
| Page separation on/off                               | Printer Switch 0E, bit 2    | Enabled                  |
| Page separation mark on/off                          | Printer Switch 00, bit 0    | Enabled                  |
| Image duplication with page separation, on/off       | Printer Switch 00, bit 1    | Enabled                  |
| Length of the repeated image on the next page        | Printer Switch 04, bits 5-6 | 10 mm                    |

## 8.4 PAGE REDUCTION

This function allows a received fax image to be printed on paper which has less width than the fax image.

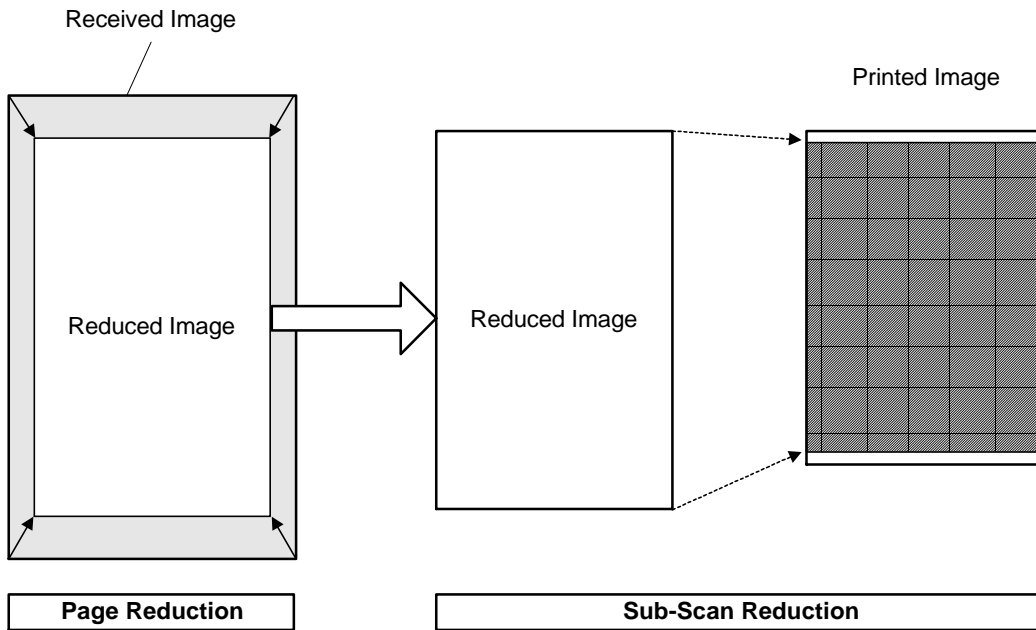

A194D507.wmf

First, the received image is reduced by a fixed reduction rate in the main and sub scan directions. The available reduction rates are as follows:

- 84% - A3 to B4 reduction
- 82% - B4 to A4 lengthwise reduction

Then, the reduced image is further reduced (if necessary) in the sub-scan direction so that it can be printed on one page. However, if the FCU detects that the image does not fit on one page after sub-scan reduction, the FCU cancels the page reduction, but uses normal sub-scan reduction on the received fax image.

**Notes**

- Sub-scan reduction is automatically enabled when Page Reduction is enabled.

- A3 to A4 reduction is not available.

### Cross Reference

Page reduction on/off - User parameter 10 (0A), bit 3 (Default: Disabled)

## Examples

1. When printing a B4 size fax image on 8.5" x 11" lengthwise paper

- Fax image size: 256 x 364 mm (10.7 x 14.3")
- Paper size: 216 x 279 mm (8.5 x 11")
- Reduction rate used: 82%
- Page separation threshold: 20 mm

The received image is printed on one 8.5 x 11" sheet, because the image length after page reduction ( $364 \text{ mm} \times 82\% = 298.5 \text{ mm}$ ) is shorter than the paper length (279 mm) plus 20 mm.

2. When printing a non-standard size (256 x 400 mm) fax image on 8.5 x 11" lengthwise paper

- Fax image size: 256 x 400 mm (10.7 x 15.7")
- Paper size: 216 x 279 mm (8.5 x 11")
- Reduction rate used: 82%
- Page separation threshold: 20 mm

The received fax image is printed on two 8.5 x 11" sheets after page separation and image rotation, because the image length after page reduction ( $400 \text{ mm} \times 82\% = 328 \text{ mm}$ ) is longer than the paper length (279 mm) plus 20 mm.

Refer to the "Paper Size Selection Priorities" table later in this chapter.

## 8.5 TWO IN ONE

This function allows two small pages to be printed on one sheet of paper. However, this function only works when the machine does not have the following size of paper in the cassette.

- The same size of paper as the received image
- The paper which has the same width and sufficient length

### Cross Reference

Two in one on/off - User parameter 10 (0A), bit 1 (Default: Disabled)

### 8.6 PAPER SIZE SELECTION PRIORITIES



|                                 |          |
|---------------------------------|----------|
| Page Reduction                  | Disabled |
| Reduction in Sub-scan Direction | Disabled |
| Page Separation Threshold       |          |
| Width or Length Priority        | Width    |

: Image Rotation

: Half of the page is blank

: Page Reduction

|                         |    | Received Image Size |         |         |         |         |         |         |         |         |         |         |
|-------------------------|----|---------------------|---------|---------|---------|---------|---------|---------|---------|---------|---------|---------|
|                         |    | A3                  | B4      | A4      | A4      | B5      | A5      | 11x17"  | 8.5x14" | 8.5x11" | 8.5x11" | F/F4    |
| Paper Select Priorities | 1  | A3                  | B4      | A4      | A4      | B5      | A5      | 11x17"  | 8.5x14" | 8.5x11" | 8.5x11" | F/F4    |
|                         | 2  | 11x17"              | A3      | A4      | A4      | B5      | 8.5x11" | A3      | A4      | 8.5x11" | 8.5x11" | 8.5x14" |
|                         | 3  | A4                  | 11x17"  | F/F4    | 8.5x11" | B4      | 8.5x11" | A4      | A4      | A4      | A3      | A4      |
|                         | 4  | A4                  | B5      | 8.5x14" | 8.5x11" | A4      | A4      | A4      | 8.5x11" | A4      | 11x17"  | A4      |
|                         | 5  | 8.5x11"             | B5      | A3      | A3      | A4      | A4      | 8.5x11" | 8.5x11" | F/F4    | A4      | 8.5x11" |
|                         | 6  | 8.5x11"             | A4      | 8.5x11" | F/F4    | 8.5x11" | F/F4    | 8.5x11" | F/F4    | 8.5x14" | A4      | 8.5x11" |
|                         | 7  | F/F4                | A4      | 8.5x11" | 11x17"  | 8.5x11" | 8.5x14" | F/F4    | B4      | A3      | F/F4    | B4      |
|                         | 8  | B4                  | 8.5x11" | B4      | B4      | F/F4    | B5      | B4      | A3      | B4      | B4      | A3      |
|                         | 9  | 8.5x14"             | 8.5x11" | 11x17"  | 8.5x14" | A3      | B5      | 8.5x14" | 11x17"  | 11x17"  | 8.5x14" | 11x17"  |
|                         | 10 |                     | F/F4    | A5      |         | 11x17"  | A3      |         | A5      | A5      |         | A5      |
|                         | 11 |                     | 8.5x14" | B5      |         | 8.5x14" | B4      |         | B5      | B5      |         | B5      |
|                         | 12 |                     |         | B5      |         |         | 11x17"  |         | B5      | B5      |         | B5      |

Detailed Section Descriptions

Lengthwise

Sideways

|                                 |          |
|---------------------------------|----------|
| Page Reduction                  | Disabled |
| Reduction in Sub-scan Direction | Enabled  |
| Page Separation Threshold       | 20 mm    |
| Width or Length Priority        | Width    |

 : Image Rotation

 : Half of the page is blank



 : Page Reduction

|                         |    | Received Image Size |         |         |         |         |         |         |         |         |         |         |
|-------------------------|----|---------------------|---------|---------|---------|---------|---------|---------|---------|---------|---------|---------|
|                         |    | A3                  | B4      | A4      | A4      | B5      | A5      | 11x17"  | 8.5x14" | 8.5x11" | 8.5x11" | F/F4    |
| Paper Select Priorities | 1  | A3                  | B4      | A4      | A4      | B5      | A5      | A3      | 8.5x14" | 8.5x11" | A4      | F/F4    |
|                         | 2  | 11x17"              | A3      | A4      | A4      | B5      | 8.5x11" | 11x17"  | A4      | 8.5x11" | A4      | 8.5x14" |
|                         | 3  | A4                  | 11x17"  | F/F4    | 8.5x11" | B4      | 8.5x11" | A4      | A4      | A4      | 8.5x11" | A4      |
|                         | 4  | A4                  | B5      | 8.5x14" | 8.5x11" | A4      | A4      | A4      | 8.5x11" | A4      | 8.5x11" | A4      |
|                         | 5  | 8.5x11"             | B5      | A3      | A3      | A4      | A4      | 8.5x11" | 8.5x11" | F/F4    | A3      | 8.5x11" |
|                         | 6  | 8.5x11"             | A4      | 8.5x11" | F/F4    | 8.5x11" | F/F4    | 8.5x11" | F/F4    | 8.5x14" | F/F4    | 8.5x11" |
|                         | 7  | F/F4                | A4      | 8.5x11" | 11x17"  | 8.5x11" | 8.5x14" | F/F4    | B4      | A3      | 11x17"  | B4      |
|                         | 8  | B4                  | 8.5x11" | B4      | B4      | F/F4    | B5      | B4      | A3      | B4      | B4      | A3      |
|                         | 9  | 8.5x14"             | 8.5x11" | 11x17"  | 8.5x14" | A3      | B5      | 8.5x14" | 11x17"  | 11x17"  | 8.5x14" | 11x17"  |
|                         | 10 |                     | F/F4    | A5      |         | 11x17"  | A3      |         | A5      | A5      |         | A5      |
|                         | 11 |                     | 8.5x14" | B5      |         | 8.5x14" | B4      |         | B5      | B5      |         | B5      |
|                         | 12 |                     |         | B5      |         |         | 11x17"  |         | B5      | B5      |         | B5      |

 Lengthwise

 Sideways

|                                 |          |
|---------------------------------|----------|
| Page Reduction                  | Disabled |
| Reduction in Sub-scan Direction | Disabled |
| Page Separation Threshold       |          |
| Width or Length Priority        | Length   |

-  : Image Rotation
-  : Half of the page is blank
-  : Page Reduction

|                         |    | Received Image Size |         |         |         |         |         |         |         |         |         |         |
|-------------------------|----|---------------------|---------|---------|---------|---------|---------|---------|---------|---------|---------|---------|
|                         |    | A3                  | B4      | A4      | A4      | B5      | A5      | 11x17"  | 8.5x14" | 8.5x11" | 8.5x11" | F/F4    |
| Paper Select Priorities | 1  | A3                  | B4      | A4      | A4      | B5      | A5      | 11x17"  | 8.5x14" | 8.5x11" | 8.5x11" | F/F4    |
|                         | 2  | 11x17"              | A3      | A4      | A4      | B5      | 8.5x11" | A3      | B4      | 8.5x11" | 8.5x11" | 8.5x14" |
|                         | 3  | A4                  | 11x17"  | F/F4    | 8.5x11" | B4      | 8.5x11" | A4      | A3      | A4      | F/F4    | B4      |
|                         | 4  | A4                  | B5      | 8.5x14" | 8.5x11" | A4      | A4      | A4      | 11x17"  | A4      | A3      | A3      |
|                         | 5  | 8.5x11"             | B5      | A3      | A3      | A4      | A4      | 8.5x11" | A4      | F/F4    | 11x17"  | 11x17"  |
|                         | 6  | 8.5x11"             | A4      | B4      | F/F4    | 8.5x11" | F/F4    | 8.5x11" | A4      | 8.5x14" | B4      | A4      |
|                         | 7  | F/F4                | A4      | 11x17"  | 11x17"  | 8.5x11" | 8.5x14" | F/F4    | 8.5x11" | A3      | 8.5x14" | A4      |
|                         | 8  | B4                  | 8.5x11" | 8.5x11" | B4      | F/F4    | A3      | B4      | 8.5x11" | B4      | A4      | 8.5x11" |
|                         | 9  | 8.5x14"             | 8.5x11" | 8.5x11" | 8.5x14" | A3      | B4      | 8.5x14" | F/F4    | 11x17"  | A4      | 8.5x11" |
|                         | 10 |                     | F/F4    | A5      |         | 11x17"  | 11x17"  |         | A5      | A5      |         | A5      |
|                         | 11 |                     | 8.5x14" | B5      |         | 8.5x14" | B5      |         | B5      | B5      |         | B5      |
|                         | 12 |                     |         | B5      |         |         | B5      |         | B5      | B5      |         | B5      |

Detailed Section Descriptions

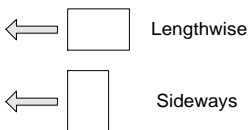





























































A194D512.wmf

|                                 |          |
|---------------------------------|----------|
| Page Reduction                  | Disabled |
| Reduction in Sub-scan Direction | Enabled  |
| Page Separation Threshold       | 20 mm    |
| Width or Length Priority        | Length   |

 : Image Rotation

 : Half of the page is blank

 : Page Reduction



|                         |    | Received Image Size   |   |   |   |   |   |   |   |   |   |   |
|-------------------------|----|---|---|---|---|---|---|---|---|---|---|---|
|                         |    | A3  | B4  | A4  | A4  | B5  | A5  | 11x17"  | 8.5x14"   | 8.5x11"   | 8.5x11"   | F/F4  |
| Paper Select Priorities | 1  | A3  | B4  | A4  | A4  | B5  | A5  | A3  | 8.5x14"   | 8.5x11"   | A4  | F/F4  |
|                         | 2  | 11x17"  | A3  | A4         | A4         | B5         | 8.5x11"   | 11x17"  | B4  | 8.5x11"  | A4       | 8.5x14"   |
|                         | 3  | A4         | 11x17"  | F/F4  | 8.5x11"    | B4  | 8.5x11"  | A4         | A3  | A4  | 8.5x11"    | B4  |
|                         | 4  | A4         | B5  | 8.5x14"   | 8.5x11"    | A4  | A4  | A4         | 11x17"  | A4         | 8.5x11"    | A3  |
|                         | 5  | 8.5x11"    | B5         | A3         | A3         | A4         | A4       | 8.5x11"    | A4  | F/F4  | A3  | 11x17"  |
|                         | 6  | 8.5x11"    | A4         | B4  | F/F4  | 8.5x11"    | F/F4  | 8.5x11"    | A4         | 8.5x14"   | F/F4  | A4  |
|                         | 7  | F/F4     | A4       | 11x17"  | 11x17"  | 8.5x11"  | 8.5x14"   | F/F4     | 8.5x11"  | A3  | 11x17"  | A4       |
|                         | 8  | B4       | 8.5x11"  | 8.5x11"  | B4       | F/F4  | A3     | B4       | 8.5x11"  | B4  | B4  | 8.5x11"  |
|                         | 9  | 8.5x14"  | 8.5x11"  | 8.5x11"  | 8.5x14"  | A3  | B4  | 8.5x14"  | F/F4  | 11x17"  | 8.5x14"  | 8.5x11"  |
|                         | 10 |   | F/F4     | A5  |   | 11x17"  | 11x17"  |   | A5       | A5  |   | A5       |
|                         | 11 |   | 8.5x14"  | B5  |   | 8.5x14"  | B5  |   | B5       | B5  |   | B5       |
|                         | 12 |   |   | B5       |   |   | B5     |   | B5       | B5       |   | B5       |

  Lengthwise

  Sideways



|                                 |         |
|---------------------------------|---------|
| Page Reduction                  | Enabled |
| Reduction in Sub-scan Direction | Enabled |
| Page Separation Threshold       | 20 mm   |
| Width or Length Priority        | Width   |

-  : Image Rotation
-  : Half of the page is blank
-  : Page Reduction

|                         |    | Received Image Size |         |         |         |         |         |         |         |         |         |         |
|-------------------------|----|---------------------|---------|---------|---------|---------|---------|---------|---------|---------|---------|---------|
|                         |    | A3                  | B4      | A4      | A4      | B5      | A5      | 11x17"  | 8.5x14" | 8.5x11" | 8.5x11" | F/F4    |
| Paper Select Priorities | 1  | A3                  | B4      | A4      | A4      | B5      | A5      | A3      | 8.5x14" | 8.5x11" | A4      | F/F4    |
|                         | 2  | 11x17"              | A4      | A4      | A4      | B5      | 8.5x11" | 11x17"  | A4      | 8.5x11" | A4      | 8.5x14" |
|                         | 3  | B4                  | A4      | F/F4    | 8.5x11" | B4      | 8.5x11" | B4      | A4      | A4      | 8.5x11" | A4      |
|                         | 4  | A4                  | F/F4    | 8.5x14" | 8.5x11" | A4      | A4      | A4      | 8.5x11" | A4      | 8.5x11" | A4      |
|                         | 5  | A4                  | 8.5x14" | A3      | A3      | A4      | A4      | A4      | 8.5x11" | F/F4    | A3      | 8.5x11" |
|                         | 6  | 8.5x11"             | A3      | 8.5x11" | F/F4    | 8.5x11" | F/F4    | 8.5x11" | F/F4    | 8.5x14" | F/F4    | 8.5x11" |
|                         | 7  | 8.5x11"             | 11x17"  | 8.5x11" | 11x17"  | 8.5x11" | 8.5x14" | 8.5x11" | B4      | A3      | 11x17"  | B4      |
|                         | 8  | F/F4                | B5      | B4      | B4      | F/F4    | B5      | F/F4    | A3      | B4      | B4      | A3      |
|                         | 9  | 8.5x14"             | B5      | 11x17"  | 8.5x14" | A3      | B5      | 8.5x14" | 11x17"  | 11x17"  | 8.5x14" | 11x17"  |
|                         | 10 |                     | 8.5x11" | A5      |         | 11x17"  | A3      |         | A5      | A5      |         | A5      |
|                         | 11 |                     | 8.5x11" | B5      |         | 8.5x14" | B4      |         | B5      | B5      |         | B5      |
|                         | 12 |                     |         | B5      |         |         | 11x17"  |         | B5      | B5      |         | B5      |

Detailed Section Descriptions

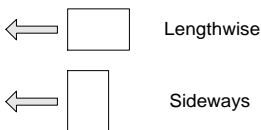

































































A194D514.wmf

|                                 |         |
|---------------------------------|---------|
| Page Reduction                  | Enabled |
| Reduction in Sub-scan Direction | Enabled |
| Page Separation Threshold       | 20 mm   |
| Width or Length Priority        | Length  |

 : Image Rotation

 : Half of the page is blank

 : Page Reduction

|                         |    | Received Image Size   |   |   |   |   |   |   |   |   |   |   |
|-------------------------|----|---|---|---|---|---|---|---|---|---|---|---|
|                         |    | A3  | B4  | A4  | A4  | B5  | A5  | 11x17"  | 8.5x14"   | 8.5x11"   | 8.5x11"   | F/F4  |
| Paper Select Priorities | 1  | A3  | B4  | A4  | A4  | B5  | A5  | A3  | 8.5x14"   | 8.5x11"   | A4  | F/F4  |
|                         | 2  | 11x17"  | A3  | A4         | A4         | B5         | 8.5x11"   | 11x17"  | B4  | 8.5x11"  | A4       | 8.5x14"   |
|                         | 3  | B4         | 11x17"  | F/F4  | 8.5x11"    | B4  | 8.5x11"  | B4  | A3  | A4  | 8.5x11"    | B4  |
|                         | 4  | A4         | A4         | 8.5x14"   | 8.5x11"    | A4  | A4  | A4         | 11x17"  | A4         | 8.5x11"    | A3  |
|                         | 5  | A4         | A4         | A3         | A3         | A4         | A4       | A4         | A4  | F/F4  | A3  | 11x17"  |
|                         | 6  | 8.5x11"   | F/F4      | B4  | F/F4      | 8.5x11"   | F/F4  | 8.5x11"   | A4        | 8.5x14"   | F/F4      | A4        |
|                         | 7  | 8.5x11"  | 8.5x14"  | 11x17"  | 11x17"  | 8.5x11"  | 8.5x14"   | 8.5x11"  | 8.5x11"  | A3       | 11x17"  | A4       |
|                         | 8  | F/F4     | B5       | 8.5x11"  | B4       | F/F4     | A3     | F/F4     | 8.5x11"  | B4  | B4  | 8.5x11"  |
|                         | 9  | 8.5x14"  | B5       | 8.5x11"  | 8.5x14"  | A3  | B4  | 8.5x14"  | F/F4  | 11x17"  | 8.5x14"  | 8.5x11"  |
|                         | 10 |   | 8.5x11"  | A5  |   | 11x17"  | 11x17"  |   | A5       | A5  |   | A5       |
|                         | 11 |   | 8.5x11"  | B5  |   | 8.5x14"  | B5  |   | B5       | B5  |   | B5       |
|                         | 12 |   |   | B5       |   |   | B5     |   | B5       | B5       |   | B5       |

 Lengthwise

 Sideways

## 9. TWO-SIDED (DUPLEX) PRINTING

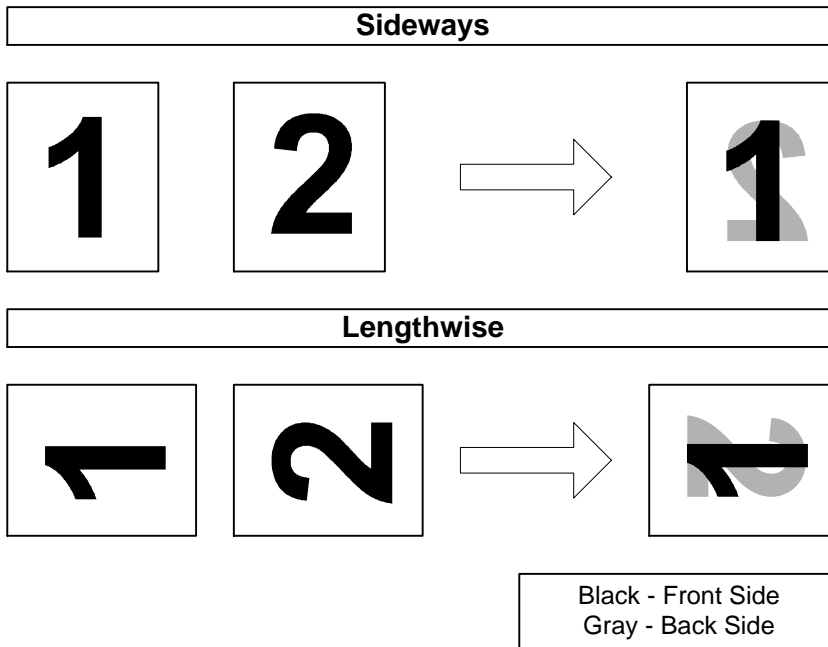

A194D517.wmf

When two-sided printing is enabled in fax mode, the machine prints two consecutive pages, which must be the same size and direction, onto both sides of the page.

As shown in the above diagram, the print results look different depending on the direction of the paper selected. When the machine selects a lengthwise (in paper feed direction) paper for printing, the back side of the paper is printed upside down.

To prevent this, carefully choose paper feed stations which the machine can print fax messages from using the Printer Switch 02.

- Notes:**
- The optional duplex unit and SAF memory are required to enable two-sided printing.
  - The machine starts printing after all pages have been received.

### Cross Reference

Duplex printing on/off for specific senders - Key operator mode 06

Duplex printing on/off for all received fax messages - Printer Switch 0F, bit 2

Wait time when duplex unit is in use - Printer Switch 0F, bits 6 and 7

Paper feed station selection for fax printing - Printer Switch 02, bits 0 to 3

# 10. PCBs

## 10.1 FCU

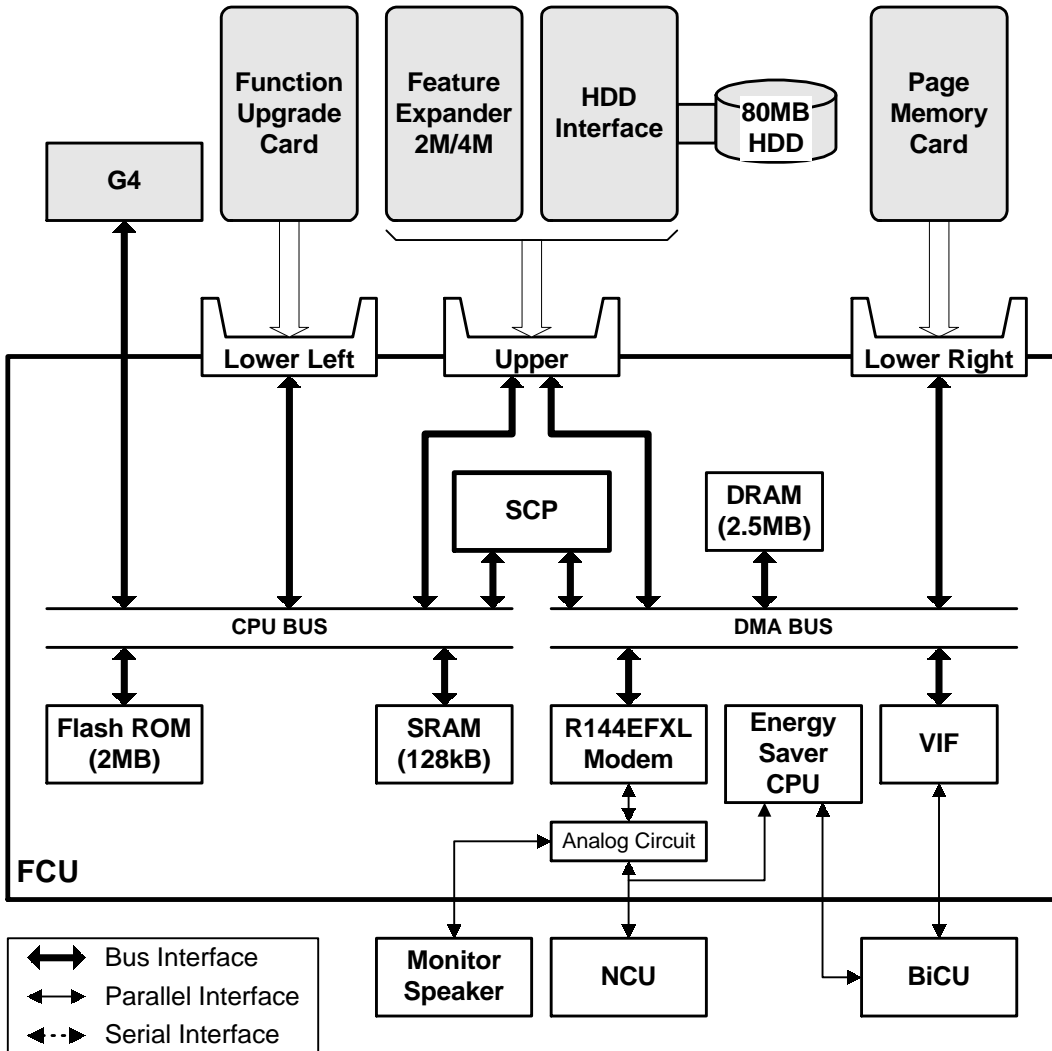

A194D516.wmf

The FCU (Facsimile Control Unit) controls fax communication, the video interface to the base copier's engine, energy saver mode, and fax options.

### 1. SCP (System Control Processor)

- CPU
- Data compression and reconstruction (DCR)
- MMR + raw data compression for SAF storage (DCMMR)
- DMA control
- Clock generation
- DRAM backup control
- Ringing signal/tone detection

**2. VIF (Video InterFace)**

- Video and command interface to the BiCU
- Smoothing
- Sub scan reduction and page reduction

**3. Modem (Rockwell R144EFL)**

- V.21, V.27ter, V.29, and V.17

**4. Energy Saver CPU**

- Power distribution control in energy saver mode

**5. ROM**

- 2MB (16 Mbit) flash ROM for system software storage

**6. DRAM**

- 2.5 MB DRAM shared between the buffer memory (384 kB), ECM Buffer (128 kB), Page Memory (1 MB), and SAF memory (1 MB)
- 1 MB SAF memory, backed up by the rechargeable battery

**7. SRAM**

- 128 kB SRAM for system and user parameter storage, backed up by the lithium battery

**8. Oscillators**

- 42.20545 MHz oscillator for system clock generation
- 32.768 MHz oscillator for the real time clock. This is backed up by the lithium battery
- 38.00053 MHz oscillator for the R144EFL modem

**9. IC Card Slots**

- Upper slot for an optional Feature Expander or a hard disk interface (SAF memory)
- Lower left slot for an optional Function Upgrade Card
- Lower right slot for an optional page memory (4 MB). The total page memory capacity will be 4 MB with this option.

**10. Jumpers, Switches, and Test Points**

| Item | Description                        |
|------|------------------------------------|
| SW1  | Switches the backup battery ON/OFF |
| SW2  | Reset switch                       |

## 10.2 NCU (US)

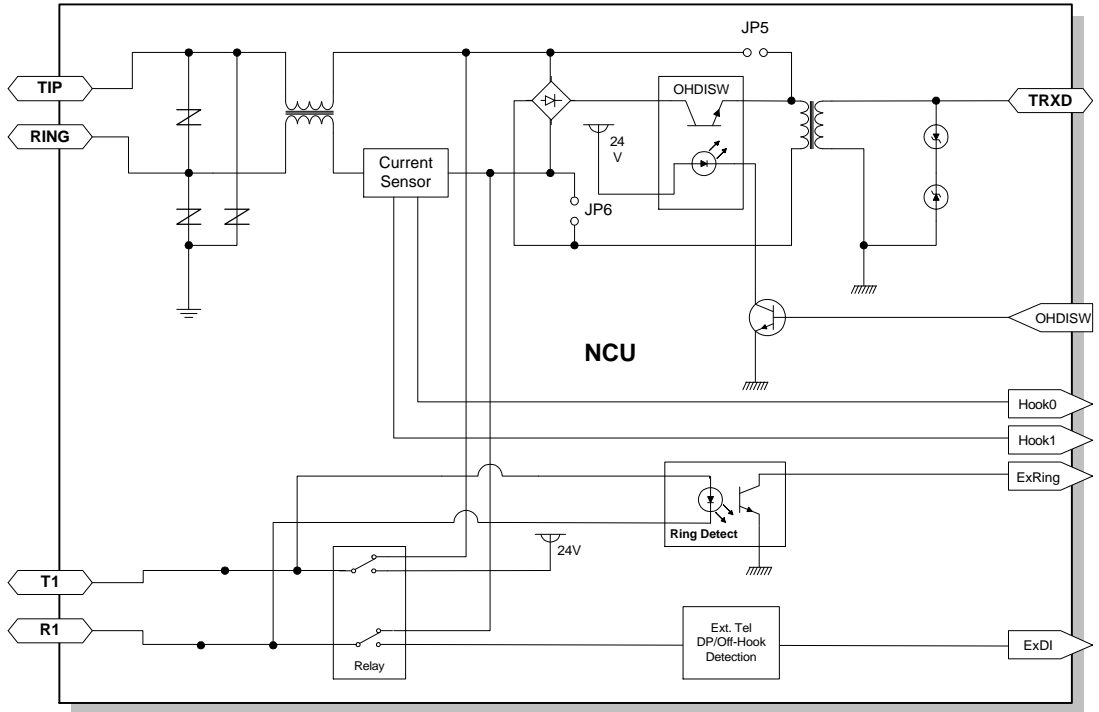

A194D521.wmf

### Jumpers

| Item | Description  |
|------|--|
| JP5  | These jumpers should be shorted when the machine is connected to a dry line. |
| JP6  |  |

### 10.3 NCU (Europe/Asia)

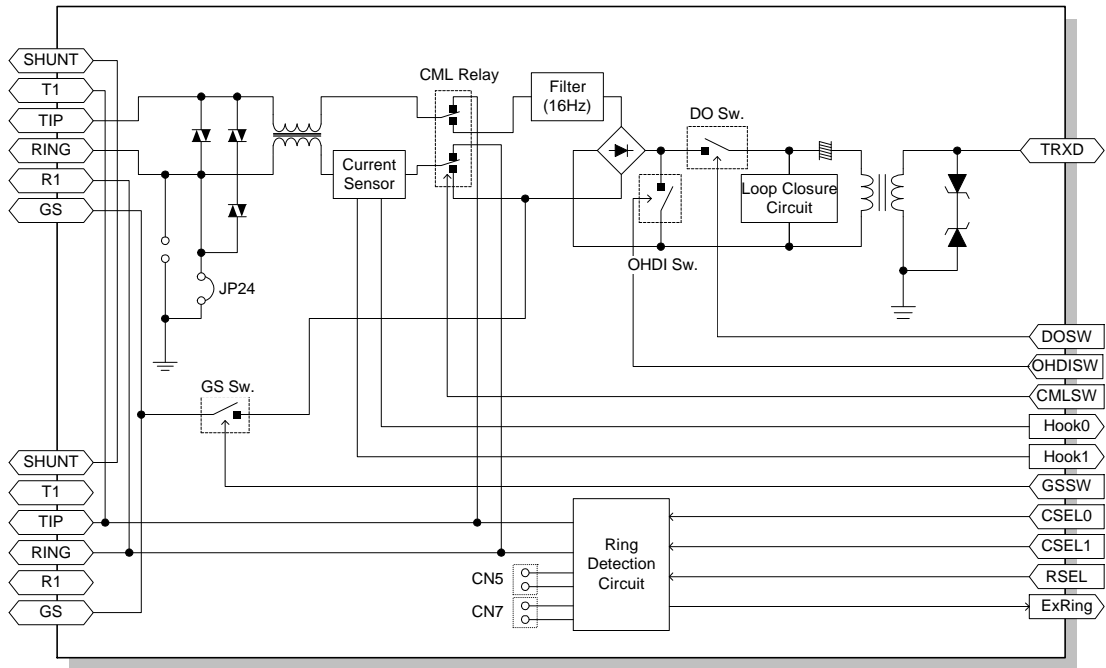

A194D521.wmf

### Control Signals and Jumpers

| Country         | CSEL0 | CSEL1 | RSEL   | JP24              | CN5 | CN7 |
|-----------------|-------|-------|--------|-------------------|-----|-----|
|                 | CN2-4 | CN2-5 | CN1-13 |                   |     |     |
| Germany         | L     | H     | H      | S                 | O   | O   |
| Holland         | L     | H     | H      | S                 | O   | O   |
| Austria         | L     | H     | H      | S                 | O   | O   |
| Italy           | L     | L     | L      | S                 | O   | O   |
| Spain           | L     | L     | L      | S                 | O   | O   |
| Ireland         | H     | L     | L      | S                 | S   | S   |
| Finland         | L     | H     | L      | O                 | O   | O   |
| Switzerland     | L     | H     | L      | O                 | O   | O   |
| Other           | L     | H     | L      | S                 | O   | O   |
| L: Low, H: High |       |       |        | S: Short, O: Open |     |     |

### 10.4 NCU (France)

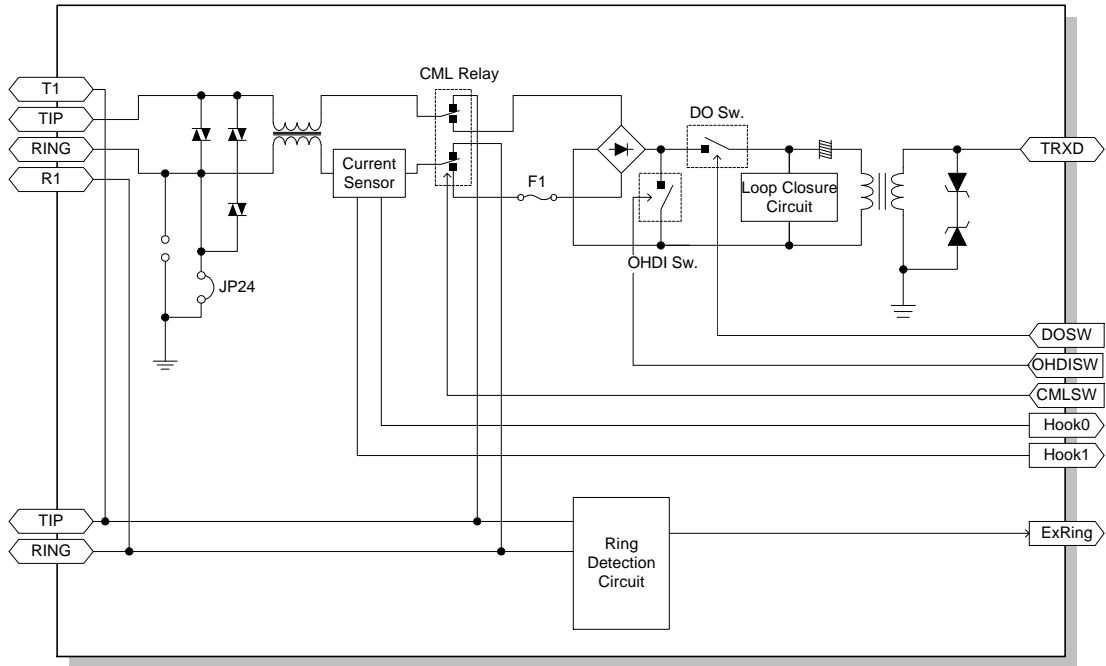

A194D522.wmf

### Jumper

| Item | Description        |
|------|--------------------|
| JP24 | Keep this shorted. |



**SECTION 3**  
**INSTALLATION**

# 1. FAX UNIT

- NOTE:**
1. Never install telephone wiring during a lightning storm.
  2. Never install telephone jacks in wet locations unless the jack is specifically designed for wet locations.
  3. Never touch uninsulated telephone wires or terminals unless the telephone line has been disconnected at the network interface.
  4. Use caution when installing or modifying telephone lines.
  5. Avoid using a telephone (other than a cordless type) during an electrical storm. There may be a remote risk of electric shock from lightning.
  6. Do not use the telephone to report a gas leak in the vicinity of the leak.

## 1.1 INSTALLATION PROCEDURE

### ⚠ CAUTION

1. Before installing the fax unit, switch off the main and ac switches, and disconnect the power cord.
2. The fax unit contains a lithium battery. The danger of explosion exists if a battery of this type is incorrectly replaced. Replace only with same or an equivalent type recommended by the manufacturer. Discard used batteries in accordance with the manufacturer's instructions

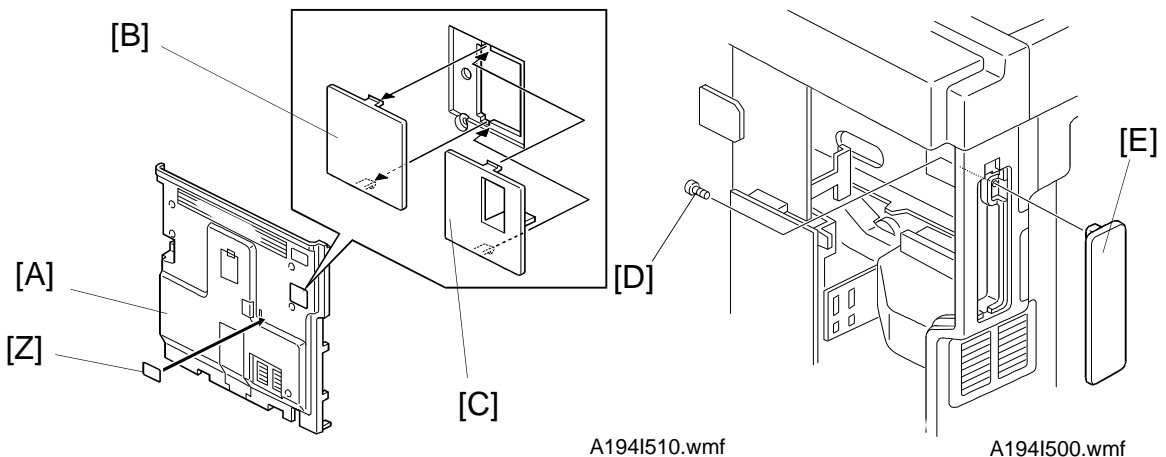

1. Remove the rear cover [A] (6 screws), replace the current NCU cover [B] with the new NCU cover [C], affix the FCC/IC label (US only) or the BAPT label (UK only) [Z].
2. Remove screw [D] and then remove the small cover [E].

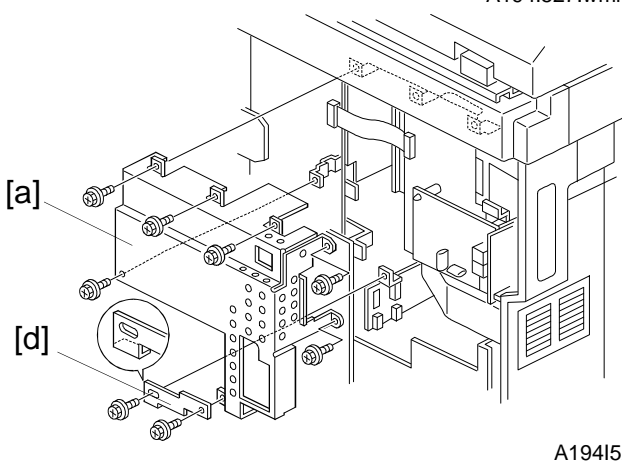
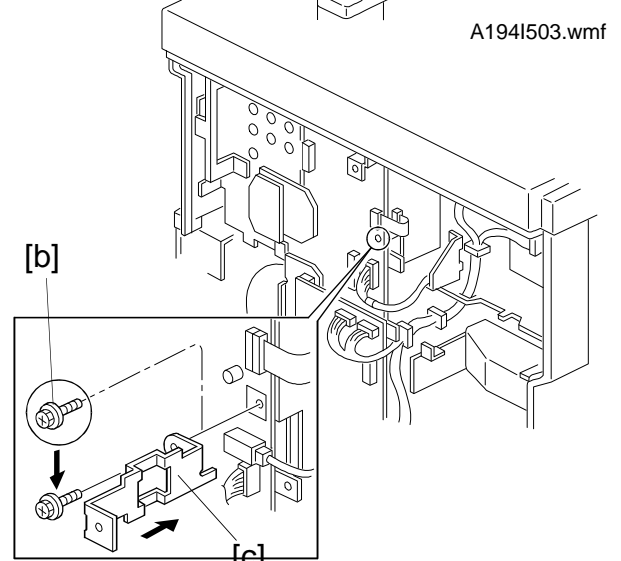
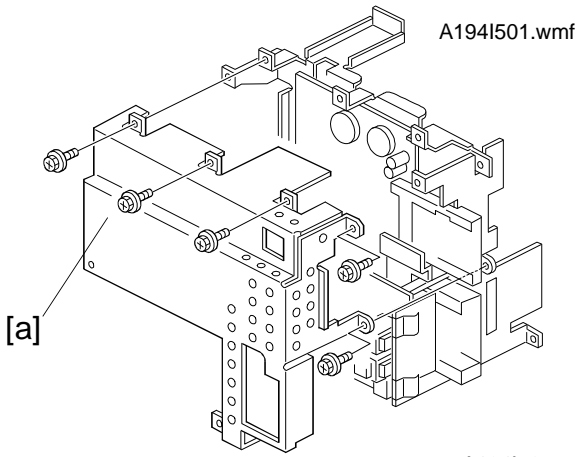
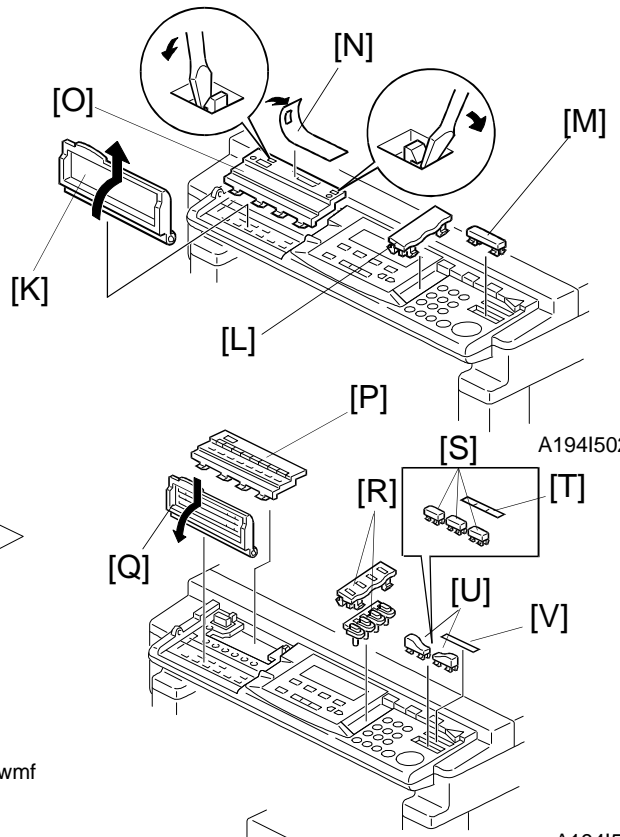
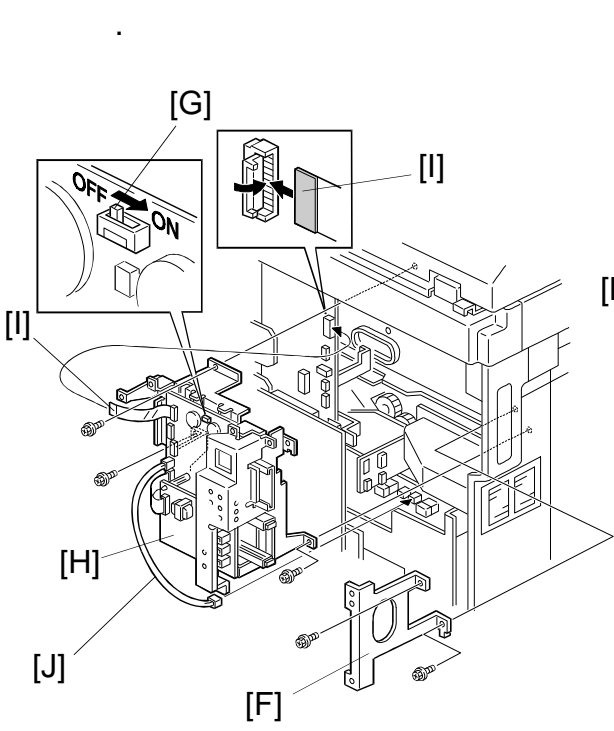

**NOTE:** For European models only, perform steps a, b, and c.

- a. Remove bracket [a], from the fax unit.
- b. Remove screw [b] and install bracket [C] as shown.
3. Remove the inner bracket [F] (2 screws).
4. Turn on the battery switch [G]. Install the fax unit [H] (4 screws), as shown.
5. Connect the flat harness [I] to the BiCU (CN304), and connect the harness [J] to the PSU (CN288).
- c. Replace bracket [a] which was removed in step [a]; and install small bracket [d]

**NOTE:** Use a magnetic screwdriver so as not to drop any screws inside the machine.

6. Replace the rear cover (5 screws).
7. Remove the parts [K], [L], and [M] from the operation panel.
8. Peel off the decal [N] as shown, then remove part [O].
9. Install each part, [P], [Q] and [R] on the operation panel, as shown.
10. If the machine has the printer controller option, install the keys [S] and the decal [T] as shown. The decal [T] has “Copy,” “Printer,” and “Facsimile” printed on it.  
If the machine does not have the printer controller option, install the keys [U] and the decal [V] as shown. The decal [V] has “Copy” and “Facsimile” printed on it

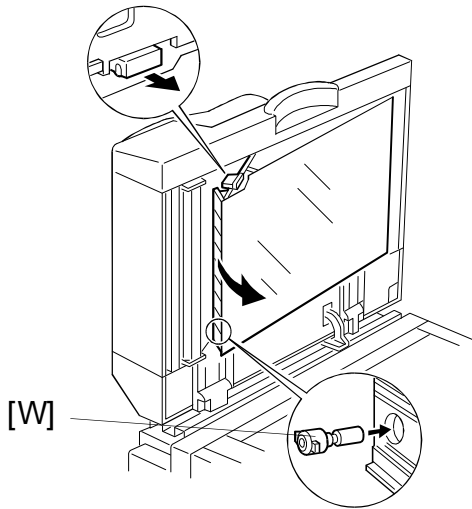

A194I523.wmf

11. Install the Stamper [W] into the ADF as shown.
12. Plug in the machine and turn on the ac and main switches.
13. Press the 'Facsimile' key and check that the facsimile LED lights. At this time, the following message should be shown:

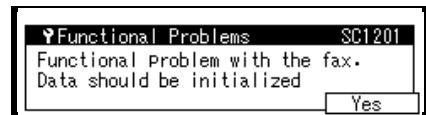

A194I520.img

**NOTE:** This is not a functional problem. The machine shows this message only when the fax unit is installed for the first time.

14. Press "Yes" to initialize the fax unit.
15. Connect the telephone cable to the "LINE" jack at the rear of the machine.
16. Set up and program the items required for fax communications, as shown below. If the user function keys (F1, F2, F3 and F4) need to be programmed, affix the enclosed label above the function keys.

The default settings of the user function keys are as follows:

- F1 - Start Manual Rx
- F2 - TEL Mode
- F3 - Tx Result Display
- F4 - Not programmed

17. (US only) If the optional handset needs to be installed, refer to section 4 'HANDSET' for the installation procedure.

18. In European countries where the usage of RJ11 type 'TEL' jack is prohibited by local PTT, the plug [X] in the 'TEL' jack as shown.

- NOTE:**
- Be sure to set the clock (date and time).
  - Program the serial number into the fax unit (service function 10). The serial number can be found on the serial number label (which has been attached to the machine in step 12).

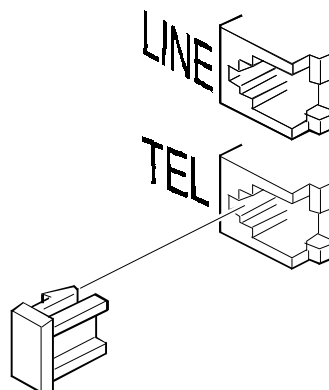

A194I524.wmf

## 1.2 INITIAL PROGRAMMING

### Key-operator Level

|   |                          |
|---|--------------------------|
| Clock   | Key-operator mode 19     |
| Transmit mode   | Initial setup (Transmit) |
| Resolution  | Initial setup (Transmit) |
| Photo original  | Initial setup (Transmit) |
| Reception mode  | Initial setup (Receive)  |
| Auto image density                                    | Initial setup (Receive)  |
| ID code   | Key-operator mode 01     |
| ECM   | Key-operator mode 02     |
| Volume  | Key-operator mode 09     |
| TTI / RTI   | Key-operator mode 11     |
| Economy transmission                                  | Key-operator mode 12     |
| G3 setting(Analog line)<br>(Line type/CSI/Own number) | Key-operator mode 14     |
| User parameters                                       | Key-operator mode 17     |

**Service Level**

|   |                 |
|---|-----------------|
| NCU country code (NCU parameter C.C.)                   | Function 06 - 2 |
| Bit switch country code (System switch 0F)              | Function 01 - 1 |
| Local dialing requirements<br>(Communication switch 06) | Function 01 - 4 |
| Local protocol requirements (G3 switch 0B)              | Function 01 - 5 |
| PBX access code (RAM address 4800BB)                    | Function 06 - 1 |
| Machine's serial number                                 | Function 10     |
| Service station's fax number                            | Function 09     |
| PM call (System switch 01- bit 0)                       | Function 01 - 1 |
| Periodic service call<br>(RAM address 480379 - 48037D)  | Function 06 - 1 |

## 2. ISDN G4 UNIT

### 2.1 INSTALLATION PROCEDURE

**⚠ CAUTION**

Before installing an optional unit, do the following:

1. Print out all messages stored in memory.
2. Print out the lists of user-programmed items and the system parameter list.
3. Switch off the main and ac switches, then disconnect the power cord and the telephone cable.

Installation

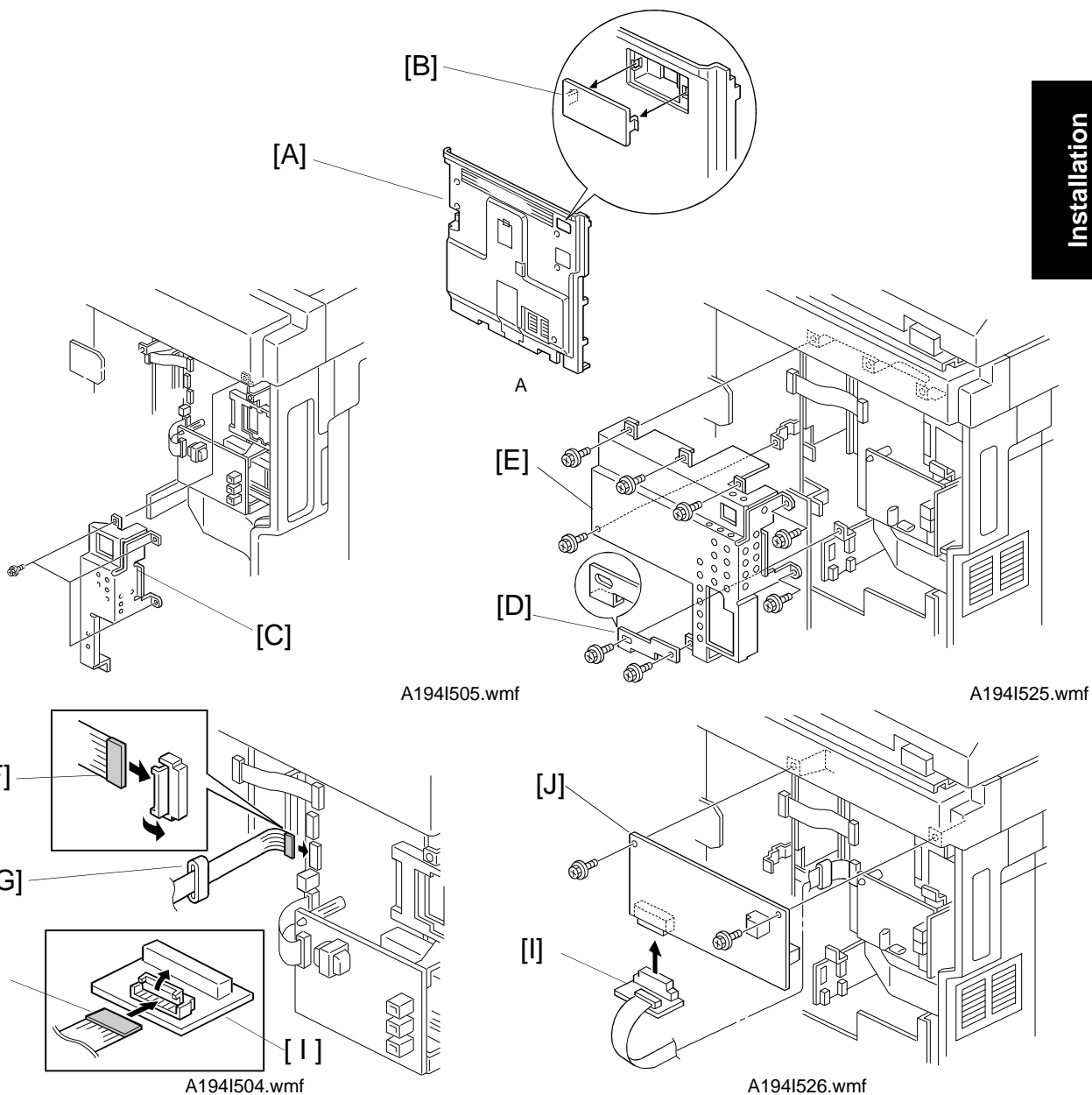



1. Remove the rear cover [A] (6 screws). Then remove the cover [B] from the rear cover.

2. **[US model]** Remove the bracket [C] (3 screws).

**[Europ/Asia model]** Remove the bracket [D] (2 screws) and [E] (6 screws).

3. Connect one end of the flat harness [F] to CN505 on the FCU, put the harness through the metal core [G], and other end of the flat harness [H] to the interface board [ I ].

4. Install the CiG4 board [J] onto the fax unit (2 screws).

5. Attach the interface board [ I ] to the CiG4 board [J].

6. **[US model]** Rplace the bracket [C] (3 screws).

**[Europ/Asia model]** Replace the bracket [E] (6 screws) and [D] (2 screws) .

7. Replace the rear cover (6 screws).

8. Place the enclosed 'G4' label in the function key (F4) space.

After G4 unit installation, this key is dedicated to switching between the G3 and G4 communication modes (note the user function key assignment table, below).

| Function Key | Without G4 unit   | With G4 unit                       |
|--------------|-------------------|------------------------------------|
| <b>F1</b>    | Start Manual Rx   | Manual reception                   |
| <b>F2</b>    | TEL mode          | TEL mode                           |
| <b>F3</b>    | Tx result display | Tx result display                  |
| <b>F4</b>    | Not programmed    | G3/G4 communication mode selection |

9. Plug in the machine and turn on the ac and main switches.

10. Connect the ISDN cable to the ISDN jack at the rear of the machine, and the analog telephone cable to the line jack.

11. Print the system parameter list and ensure that "G4" is listed as an option.

12. Set up and program the items required for ISDN communications, as shown on the following page.

After setting up the ISDN parameters, be sure to turn the main and ac switches off and on.

## 2.2 INITIAL PROGRAMMING

### Key-operator Level

|                        |                      |
|------------------------|----------------------|
| Own ISDN - G4 number   | Key-operator mode 16 |
| G4_TID ( Terminal ID ) | Key-operator mode 16 |
| ISDN - G3 CSI          | Key-operator mode 15 |
| Own ISDN - G3 number   | Key-operator mode 15 |

### Service Level

|   |                      |
|---|----------------------|
| CiG4 Country Code (G4 Internal SW 00)   | Service mode 01      |
| ISDN international prefix   | Service mode 12-1    |
| Own ISDN-G4 number main/sub   | Service mode 12-2, 3 |
| Own ISDN-G3 number main/sub   | Service mode 12-4, 5 |
| G4 subaddress   | Service mode 12-6    |
| ISDN-G3 subaddress  | Service mode 12-7    |
| Line used for G3 transmission<br>(System switch 0A- bit 6)  | Service mode 01 - 1  |
| Line used when the machine falls<br>back to G3 from G4 (if the other<br>machine is not a G4 machine)<br>(System switch 0A- bit 7) | Service mode 01 - 1  |

- NOTE:**
1. After changing any parameter, be sure to turn off the ac and main switches, wait 5 or more seconds, then turn them back on. This ensures the new settings will take effect.
  2. Print the G4 system parameter list and make sure all parameters just programmed are listed.

## 3. HARD DISK

### 3.1 INSTALLATION PROCEDURE

**NOTE:** If the fax unit is already installed, remove the fax unit before attempting to install the hard disk. Refer to "Removal and Replacement," later in this chapter.

#### ⚠ CAUTION

1. Before installing an optional unit, do the following:
  - 1) Print out all messages stored in the memory.
  - 2) Print out the lists of user-programmed items and the system parameter list.
  - 3) Switch off the main and ac switches, and disconnect the power cord and the telephone cord.
2. The hard disk interface card contains a lithium battery. The danger of explosion exists if a battery of this type is incorrectly replaced. Replace only with the same or an equivalent type recommended by the manufacturer. Discard used batteries in accordance with the manufacturer's instructions.

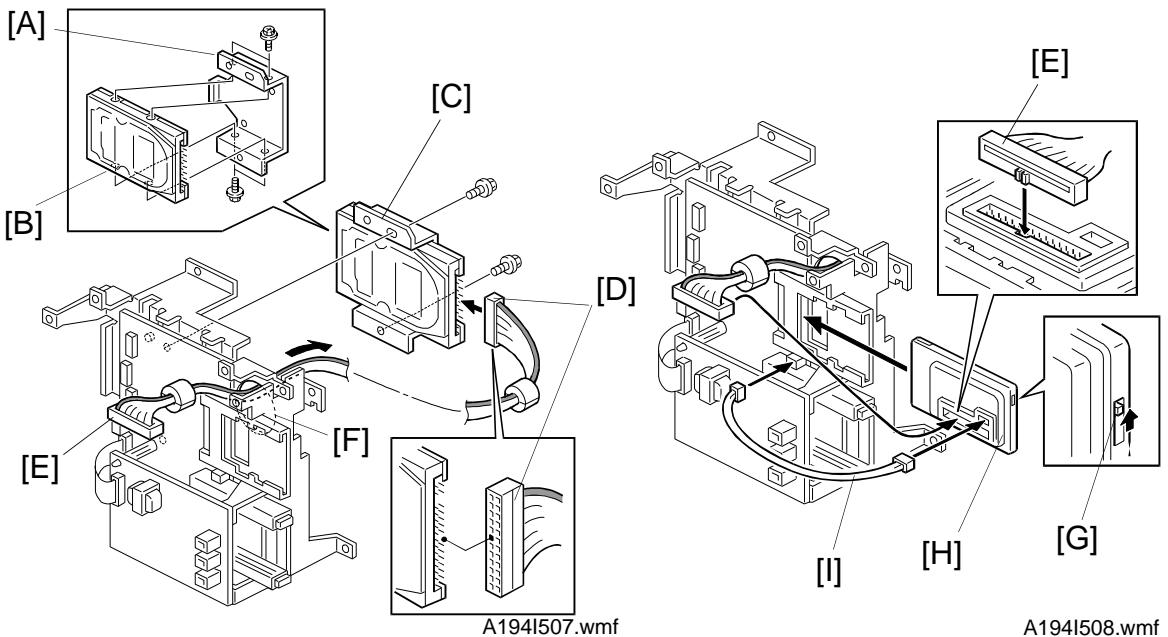

1. Attach the bracket [A] to the hard disk drive [B] (4 screws).
2. Attach the hard disk drive assembly [C] to the fax unit (2 screws).
3. Connect one end of the hard disk cable [D] to the hard disk drive, as shown, and run the other end [E] through the opening [F].

4. Turn on the battery switch [G] on the hard disk interface card [H], and insert it in the upper slot.
5. Connect the hard disk cable [E] to the interface card, as shown.
6. Connect the harness [I] (FCU-CN513).
7. Install the fax unit (See procedure 1.1).
8. Replace the rear cover.
9. Plug in the machine and turn on the ac and main switches.

### 3.2 INITIAL PROGRAMMING

1. Enter the service mode, and set bit 4 of system switch 05 to "1".
2. Exit the service mode, then turn off the ac and main switches, wait 5 or more seconds, then turn them back on.

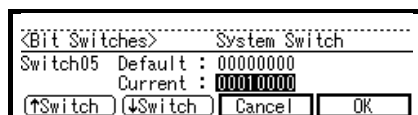

A194I521.img

3. Enter the service mode and make sure that the data in the following RAM addresses are correct (service mode 06 - RAM).  
If the data in these addresses do not match the following values, check the cable connections and the battery switch setting. Then check these addresses again. If the addresses are still incorrect, format the hard disk

| Address (H) | Data (H) |
|-------------|----------|
| 70001E      | 50       |
| 70001F      | 00       |
| 700020      | 00       |
| 700021      | FF       |
| 700022      | 00       |
| 700023      | 50       |
| 700024      | 00       |
| 700025      | 80       |

4. Initialize the memory files (service mode 07 - File initialization).
5. Print the system parameter list and make sure that "HD" is listed as an option. Also check that the memory indicator shows "100%" in standby mode.
6. Connect the telephone cord to the NCU.

## 4. HANDSET

### 4.1 INSTALLATION PROCEDURE

**NOTE:** The optional handset may not be available in some countries.

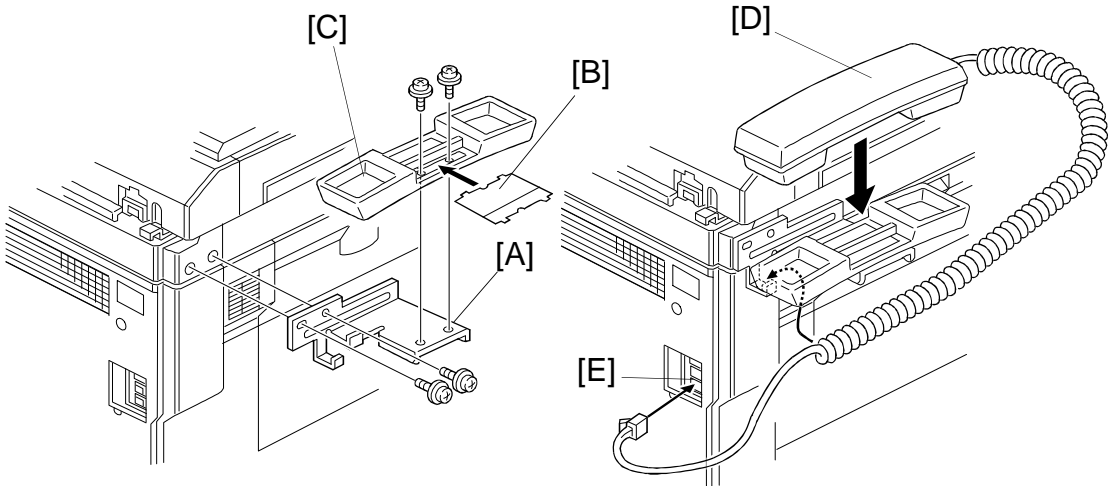

A194I511.wmf

A194I512.wmf

1. Install the bracket [A] (2 screws), as shown.
2. Remove the label [B] from the handset cradle [C]. Install the cradle on the bracket [A] (2 screws), then replace the label [B].
3. Install the handset [D], as shown. Connect the handset cord to the "TEL" jack [E] at the rear of the machine.

## 5. IC CARDS

### 5.1 INSTALLATION PROCEDURE

#### ⚠ CAUTION

Before installing an optional unit, do the following:

1. Print out all messages stored in the memory.
2. Print out the lists of user-programmed items and the system parameter list.
3. Switch off the main and ac switches, and disconnect the power cord and telephone cable.
4. Once a Function Upgrade Card has been installed, do not remove it. If removed, this will result in data being permanently lost.

#### Lithium Battery

The function upgrade card contains a lithium battery. The danger of explosion exists if a battery of this type is incorrectly replaced. Replace only with same or an equivalent type recommended by the manufacturer. Discard used batteries in accordance with the manufacturer's instructions.

1. Remove the IC card slot cover from the left side cover.
2. *Function Upgrade Card only:*  
Install a lithium battery on the IC card. (Refer to the IC card instruction manual.) Then turn on the battery switch on the IC card.
3. Install the card, with the painted face on the left, into the appropriate slot, as shown.
4. Replace the IC card slot cover.
5. Turn on the machine's ac and main switches, then press the 'Facsimile' key.

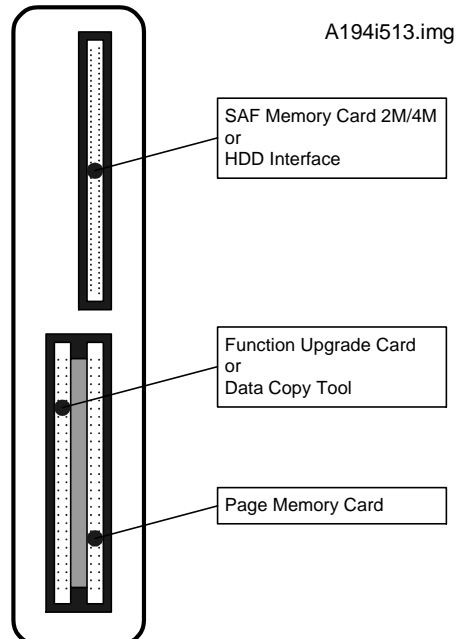
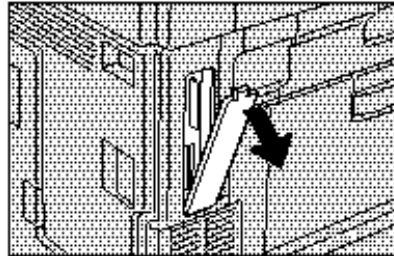

A194i514.wmf

6. *Function Upgrade Card only:*

The following message appears on the display:

**Caution!** Installing a function upgrade card causes data loss. Turn off the ac switch and remove it to avoid data loss.

To continue, press 'yes'.

Press 'Yes'.

7. Print the system parameter list. Check the following:

**SAF memory card**

"2M" or "4M" is listed as an option on the system parameter list, and that the remaining memory indicator shows 100%.

**Page Memory Card (High Resolution Card)**

"PM" is listed as an option on the system parameter list.

**Function Upgrade Card**

"Function Upgrade" is listed as an option on the system parameter list.

8. Connect the telephone cable to the NCU.

## 5.2 ITEMS INITIALIZED WHEN FUNCTION UPGRADE CARD IS INSTALLED OR REMOVED

Items initialized, at card installation, when the machine displays the following message:

**Caution!** Installing a function upgrade card causes data loss. Turn off the ac switch and remove it to avoid data loss.  
To continue, press 'yes'.

- All SAF files and Polling Rx files
- All Auto Documents
- All Specified Addresses
- All Communication Records for TCR/Journal

Items initialized, at card removal, when the machine displays the following message:

**Caution!** Installing a function upgrade card causes data loss. Turn off the ac switch and remove it to avoid data loss.  
To continue, press 'yes'.

- All SAF files and Polling Rx files
- All Keystroke Programs
- All Auto Documents
- Speed Dial 100 - 999 (these can no longer be used)
- Group 10 - 30 (these can no longer be used)
- 31st through 50th Personal Codes
- All Specified Addresses
- All Communication Records for TCR/Journal



**SECTION 4**

**SERVICE TABLES AND  
PROCEDURES**

# 1. SERVICE LEVEL FUNCTIONS

## 1.1 HOW TO ENTER AND EXIT THE FAX SERVICE MODE

To Enter the Fax Service Mode:

1. Press the 'Facsimile' key, and make sure that the 'Facsimile' LED is on.

2. Press 'User Tools' **1** **9** **8**  
**8** **↕**

The service mode main menu appears.

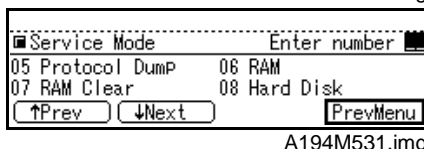
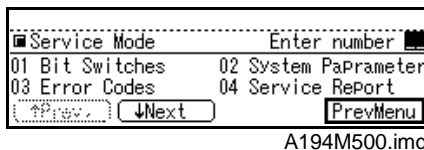

To Exit Fax Service Mode:

1. Press 'OK' or 'PrevMenu' until the service mode main menu appears.
2. Press the 'User Tools' key twice.

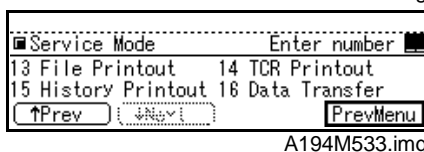
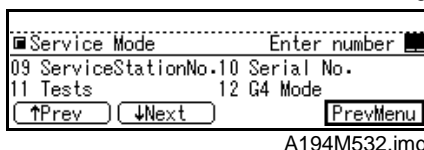

## 1.2 BIT SWITCH PROGRAMMING (FUNCTION 01)

1. Enter the fax service mode.
2. Press **0** **1**
3. Press one of the following numbers, as required:
  - 1** – System bit switches
  - 2** – Scanner bit switches
  - 3** – Printer bit switches
  - 4** – Communication bit switches
  - 5** – G3 bit switches
  - 6** – G4 internal switches
  - 7** – G4 parameter switches

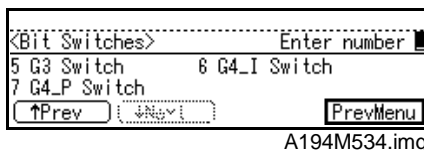
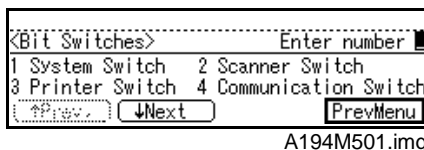

**NOTE:** An optional G4 interface is required to access the G4 internal and G4 parameter bit switches.

Example:

1. Press **1**
2. Scroll through the bit switches.

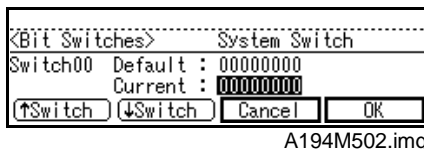

Service Tables and Procedures

To increment the bit switch number: press '↓ Switch'.

To decrement the bit switch number: press '↑ Switch'.

Example:

To display bit switch 03: Press '↓ Switch' 3 times.

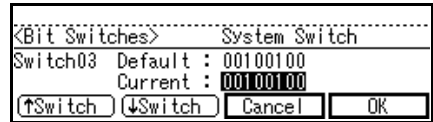

A194M503.img

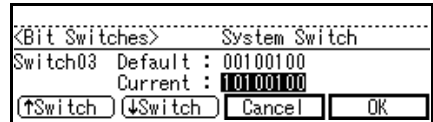

A194M504.img

3. Adjust the bit switch.

Example:

To change the value of bit 7, press 7.

4. To adjust more bit switches, go to step 2.

To finish, press 'OK' then press 'User Tools'.

5. Exit the service mode.

**NOTE:** After changing any of the G4 bit switches, be sure to turn the ac switch off and back on, so that the new settings become effective.

### 1.3 SYSTEM PARAMETER LISTS (FUNCTION 02)

1. Enter the fax service mode.

2. Press

3. Press one of the following numbers, as required:

– G3 system parameter list

– G4 system parameter list

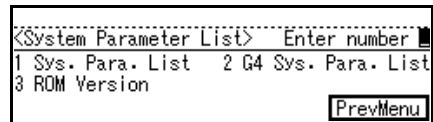

A194M505.img

**NOTE:** An optional G4 interface is required to print the G4 system parameter list.

4. Press

5. Exit the service mode.

- An example of a G3 system parameter list

```

* * * SYSTEM PARAMETER LIST (Date and Time) * * *
                                     TTI

Serial Number      - Copier's Serial number programmed by SP-Mode 5-811
Fax Serial Number - Fax serial number programmed by function 10
FAX ROM VER.      [Version] [Software release no.] [Software release date]
FAX ROM NO.       [Software part no.] [Check sum values (total) (boot) (main)]
Bicu ROM Ver.     [Software part no.]

R T I
T T I
C S I
Polling ID
Conf.ID
Number
  Own Number
  Own Number(ISDN G4)
  Own Number(ISDN G3)
  Service Number
NCU Parameters
[REDACTED]
Counter
[REDACTED]
Option
  PM                - Optional page memory card installed
  2MB, 4MB or HD    - Optional memory card or Hard Disk installed
  Function Card      - Optional function upgrade installed
  G4                 - Optional ISDN G4 kit installed
  BANK              - Optional paper feed unit installed
  ADF               - Optional ADF installed
  1-BIN             - Optional 1-bin tray installed
Service Switch (upper:Default lower:Current)
(SWUSR) - User Parameter Settings
[REDACTED]

```

```

Service Switch (upper:Default lower:Current)
  (SWSYS) - System Bit Switch Settings
  [REDACTED]
  (SWSCN) - Scanner Bit Switch Settings
  [REDACTED]
  (SWPLT) - Printer Bit Switch Settings
  [REDACTED]
  (SWCOM) - Communication Bit Switch Settings
  [REDACTED]
  (SWG3) - G3 Bit Switch Settings
  [REDACTED]

```

Service  
Tables and  
Procedures

## - An example of a G4 system parameter list

```
* * * G4 System Parameter List (Date and Time) * * *
                                     TTI
G4 ROM Data
  FAX ROM VER.      [Version] [Software release no.] [Software release date]
  G4 ROM VER.      [Software release no.] [Software release date]
G4 Terminal Data
  G4 Terminal ID      ==
  ISDN_IP
  G4 SN1 (main)
  G4 SN2 (sub)
  G4 Subaddress
G3 Terminal Data
  G3 RTI
  G3 ISDN CSI
  G3 SN1 (main)
  G3 SN2 (sub)
  G3 Subaddress
G4 Internal Switch (upper:Default lower:Current)
G4 Parameter Switch (upper:Default lower:Current)
```

### 1.4 ROM VERSION DISPLAY (FUNCTION 02)

1. Enter the fax service mode.
2. Press   then
3. Exit the service mode.

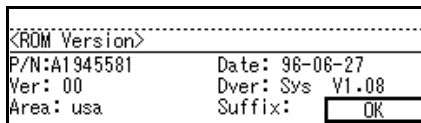

A194M506.img

### 1.5 ERROR CODE DISPLAY (FUNCTION 03)

1. Enter the fax service mode.
2. Press
3. Press either Prev. or Next to scroll through the error codes.
4. Exit the service mode.

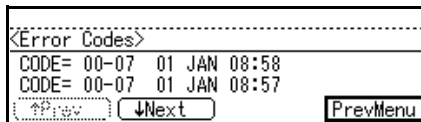

A194M507.img

### 1.6 SERVICE MONITOR REPORT (FUNCTION 04)

1. Enter the fax service mode.
2. Press   then
3. Exit the service mode.

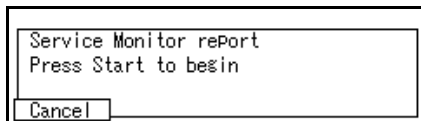

A194M508.img

### 1.7 G3 PROTOCOL DUMP LIST (FUNCTION 05)

1. Enter the fax service mode.
2. Press
3. Press  then
4. Exit the service mode.

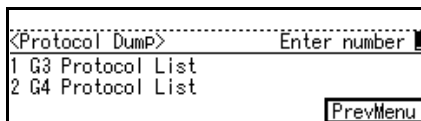

A194M509.img

### 1.8 G4 PROTOCOL DUMP LIST (FUNCTION 05)

**NOTE:** An optional G4 interface is required to print the G4 protocol dump list.

1. Enter the fax service mode.
2. Press
3. Press

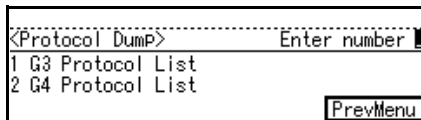

A194M509.img

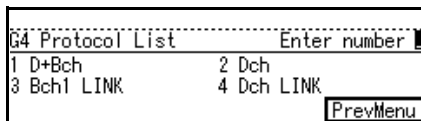

A194M510.img

Service Tables and Procedures

4. Press one of the following numbers as required:

-D + Bch

-Dch

-Bch1 Link

-Dch Link

5. Exit the service mode.

### 1.9 RAM DISPLAY AND REWRITE (FUNCTION 06)

1. Enter the fax service mode.

2. Press

3. Press

4. Enter the start address of the RAM area to be displayed, then press OK.

5. Move the cursor to the target address, using the arrow keys, then enter a new value.

6. To scroll the RAM address: press Prev. or Next.

To jump to an another address: press OK, and go back to step 4.

7. Exit the service mode.

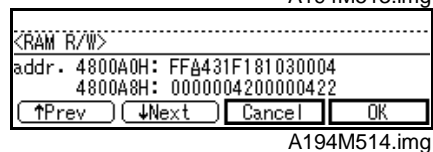
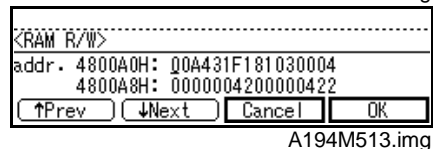
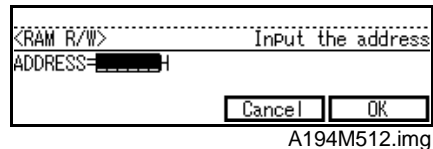
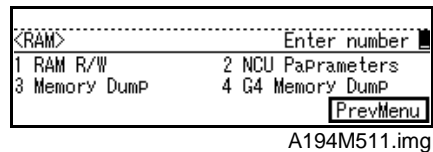

### 1.10 NCU PARAMETERS (FUNCTION 06)

1. Enter the fax service mode.

2. Press

3. Press

4. Move the cursor to the target parameter, using the arrow keys, then enter a new value.

5. Exit the service mode.

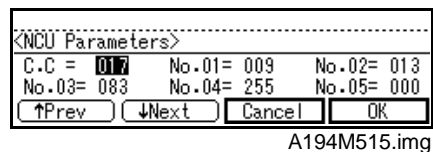
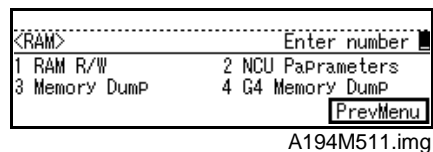

### 1.11 RAM DUMP (FUNCTION 06)

1. Enter the fax service mode.
2. Press
3. Press one of the following numbers as required:
  - G3 memory dump list
  - G4 memory dump list

**NOTE:** An optional G4 interface is required to print the G4 memory dump list.
4. Enter the first four digits of the start and end addresses, then press 

Example:  
Start at 480000, end at 4801FF
5. Exit the service mode.

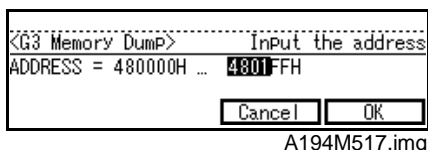
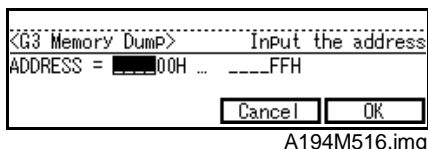
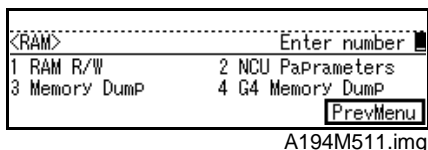

### 1.12 RAM CLEAR (FUNCTION 07)

1. Enter the fax service mode.
2. Press
3. Press one of the following numbers, as required:
  - Initializes the data in the SRAM, files in the SAF memory, and the clock.
  - Erases all the files stored in the SAF memory.
  - Resets the bit switches and the user parameters.
  - Initializes the data in the SRAM and files in the SAF memory. The machine automatically returns to standby mode after self-initialization.

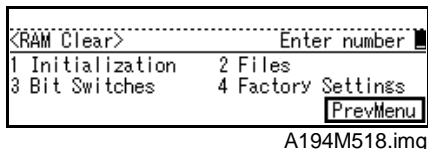

Service Tables and Procedures



To initialize the fax unit without erasing files or resetting the switches, do one of the following:

- Press the “Facsimile” key and make sure the Facsimile LED is on. Then, hold down the “Speed Dial” key for more than 10 s.
- Turn off the main and ac switches and turn them back on.
- Remove the rear cover, and press SW2 on the FCU.

### 1.13 HARD DISK (FUNCTION 08)

**NOTE:** To access this function, the hard disk option must be installed, and System Switch 05, bit 4 must be set to 1.

1. Enter the fax service mode.

2. Press

3. Press one of the following numbers, as required, then press

–Erases everything stored on the hard disk

–Low level hard disk formatting (requires over 45 min.)

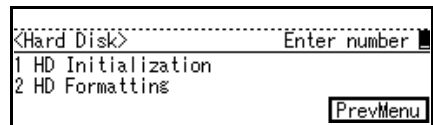

A194M519.img

**NOTE:** If there is an error during the test, the machine displays 'NG'.

4. Make sure that OK is displayed after the process, then exit the service mode.

### 1.14 SERVICE STATION FAX NUMBER (FUNCTION 09)

1. Enter the fax service mode.

2. Press

3. Enter the fax number of the service station that will receive Automatic Service Calls from this machine. To use a G4 number, press the 'F4' key.

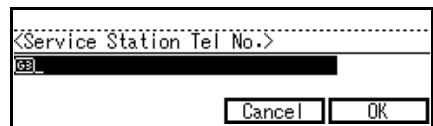

A194M520.img

4. Press OK.

5. Exit the service mode.

### 1.15 SERIAL NUMBER (FUNCTION 10)

1. Enter the fax service mode.
2. Press **1 0**
3. Enter the machine's serial number at the keypad, then press OK.
4. Exit the service mode.

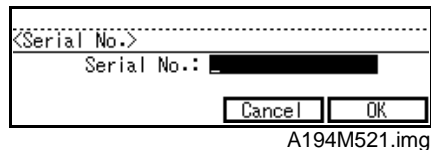

A194M521.img

### 1.16 MODEM TEST (FUNCTION 11)

1. Enter the fax service mode.
2. Press **1 1**
3. Press one of the following numbers:  
**1** – Modem test on an analog line  
**3** – Modem test on an ISDN line  
**NOTE:** An optional G4 interface is required to test a modem on an ISDN line.

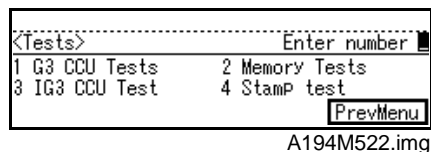

A194M522.img

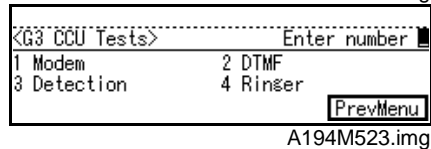

A194M523.img

4. Press **1**
5. Choose a modem type at the keypad, then press **◊**. To stop, press **C/Ⓢ**
6. Exit the service mode.

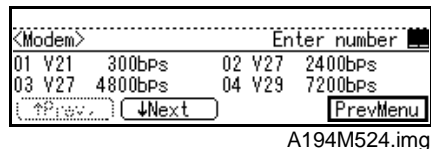

A194M524.img

### 1.17 DTMF TEST (FUNCTION 11)

1. Enter the fax service mode.
2. Press **1 1**
3. Press one of the following numbers:  
**1** – DTMF test on an analog line  
**3** – DTMF test on an ISDN line  
**NOTE:** A G4 interface is required to test DTMF tones on an ISDN line.

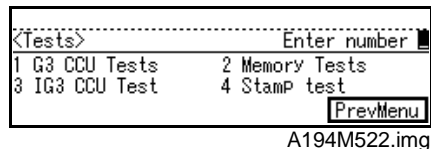

A194M522.img

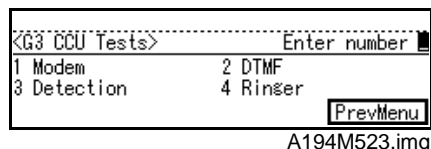

A194M523.img

4. Press **2**
5. Choose a DTMF signal type at the keypad, then press **◊**. To stop the test, press **C/Ⓢ**

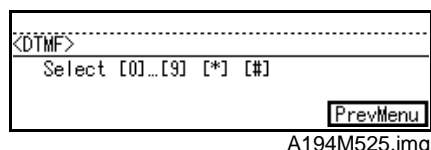

A194M525.img

Service Tables and Procedures

## 1.18 MODEM SIGNAL DETECTION TEST (FUNCTION 11)

1. Enter the fax service mode.
2. Press **1 1**
3. Press one of the following numbers, as required:
  - 1** – Modem signal detection test on an analog line
  - 3** – Modem signal detection test on a digital (ISDN) line

**NOTE:** An optional G4 interface is required to test a modem signal on an ISDN line.
4. Press **3**
5. Choose the modem signal type to be detected at the keypad, then press **◊**  
To stop the test, press **C/Ⓢ**
6. Exit the service mode.

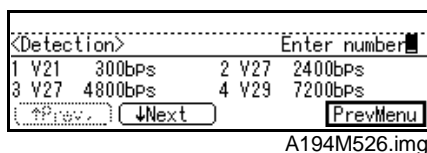
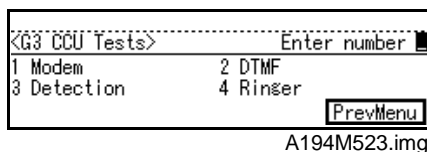
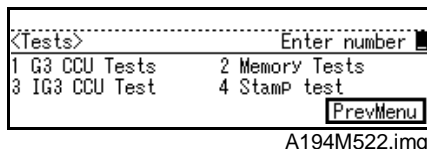

## 1.19 RINGER TEST (FUNCTION 11)

1. Enter the fax service mode.
2. Press **1 1**
3. Press **1**
4. Press **4** then **◊**  
To stop the test, press **C/Ⓢ**
5. Exit the service mode.

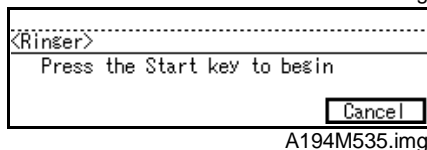
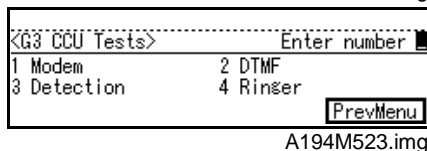
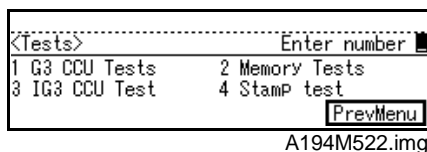

## 1.20 STAMP TEST

1. Enter the fax service mode.
2. Press **1 1**
3. Press **4** then **◊**  
To stop the test, press **C/Ⓢ**
4. Exit the service mode.

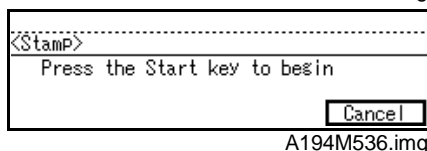
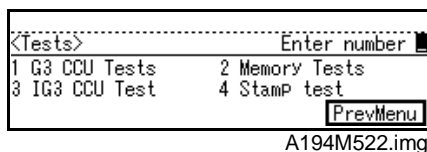

## 1.21 G4 PARAMETER PROGRAMMING (FUNCTION 12)

**NOTE:** An optional G4 interface is required to access this function.

1. Enter the fax service mode.
2. Press **1 2**
3. Press one of the following numbers, as required:

- 1** – ISDN IP (International Prefix)
- 2** – G4 SN (Subscriber Number) Main
- 3** – G4 SN (Subscriber Number) Sub
- 4** – ISDN G3 SN (Subscriber Number) Main
- 5** – ISDN G3 SN (Subscriber Number) Sub
- 6** – G4 Subaddress
- 7** – ISDN G3 Subaddress

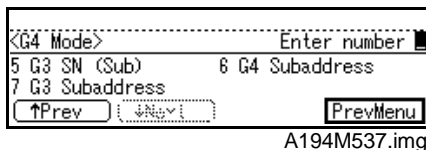
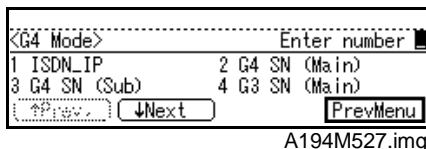

4. Program the selected item.
5. Exit the service mode.

**NOTE:** After changing any of the G4 parameters, be sure to turn the ac switch off and on, so that the new settings become effective.

## 1.22 FILE PRINTOUT (FUNCTION 13)

1. Enter the fax service mode.
2. Press **1 3** then **◆**  
The machine prints all the files stored in the SAF memory, including confidential messages.

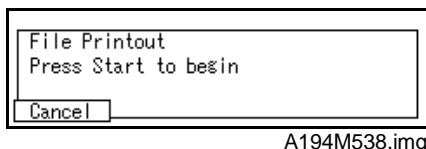

**NOTE:** Do not use this function, unless the customer is having trouble printing confidential messages or recovering from the memory lock status.

## 1.23 TCR/JOURNAL PRINTOUT (FUNCTION 14)

1. Enter the fax service mode.
2. Press **1 4**
3. Either:  
**Choose All** - The machine prints all the communication records on the report.

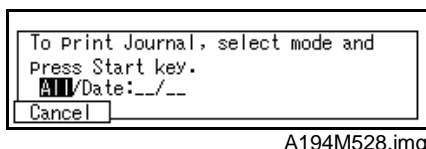

Service Tables and Procedures

The maximum number of records is 256, without the optional Function Upgrade Card, or 1000 records, with the Card.

**Specify a date** - The machine prints all communication records after the specified date.

4. Exit the service mode.

## 1.24 USAGE LOG PRINTOUT (FUNCTION 15)

The following functions are for designer use only. However, list 5 (SC history) may be useful.

1. Enter the fax service mode.

2. Press

3. Press one of the following numbers, as required, then press

- Engine interface

- Mailbox usage

- Operation trace

- Print log

- SC history

- File storage

- Scanner

- Job and SAF file creation

4. Exit the service mode.

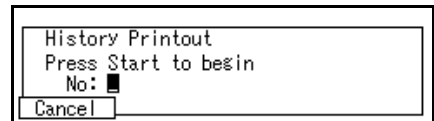

A194M529.img

## 1.25 SOFTWARE DOWNLOAD (FUNCTION 16)

This procedure copies the software from an external medium (such as an FCU board or an EPROM board), to the Flash ROM on the machine's FCU (target).



1. Turn off the machine's main and ac switches.
2. If the new software is downloaded from a FCU board, remove the IC card guiderails ([A] and [B]) in advance.

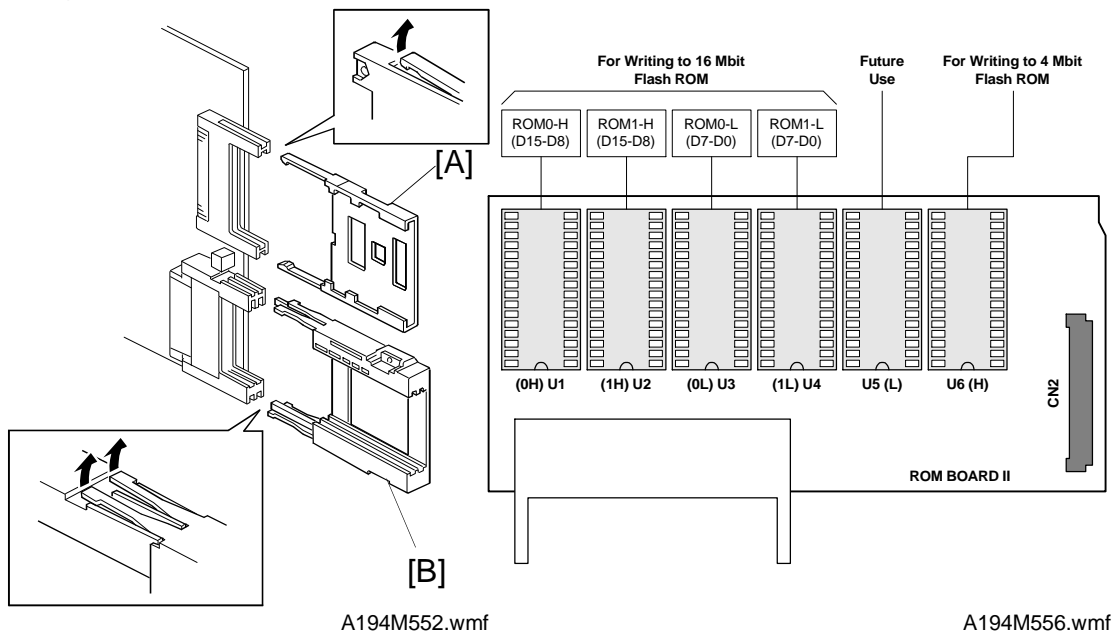

Service Tables and Procedures

3. If the new software is downloaded from an EPROM board, mount the EPROMs in the correct ROM sockets as shown in the above diagram.

The EPROM board uses four 4Mbit EPROMs.  
 Each EPROM must meet the following specifications:  
 Size: 4 Mbits Data  
 Data width: 8 bits  
 Number of pins: 32  
 Access speed: Faster than 150 ns.

4. Connect the source EPROM board [A] or FCU board [B] to the data copy tool [C], and make sure that the switch [D] on the data copy tool is on.

**⚠ CAUTION**

**If the machine has an optional Function Upgrade Card, change bit 7 of the System Switch 1E to "1", before removing the card, or the programmed data on the card may be lost. Be sure to put it back to zero before step 11 below, otherwise the fax unit will not start up without the card installed.**

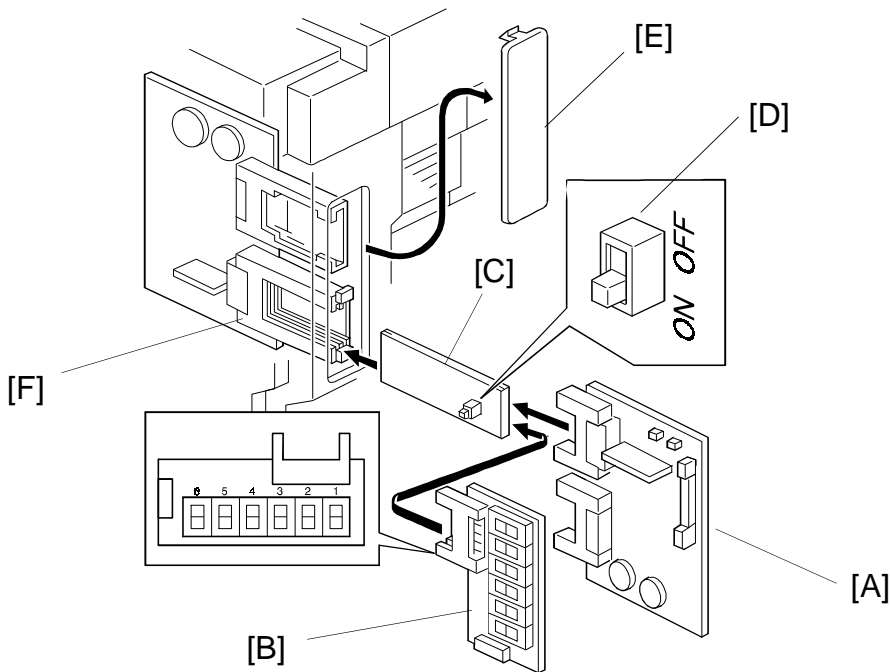

A194M553.wmf

5. Remove the cover [E], and insert the copy tool [C] in the lower left slot [F].

6. Turn on the machine's ac and main switches, then enter the fax service mode.

7. Press **1** **6**

8. Press **1** then **◊**

If the software has been successfully downloaded, the machine displays 'OK'.  
Otherwise, the machine displays 'NG'.

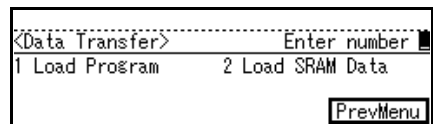

A194M530.img

9. Exit service mode, then turn off the ac and main switches, and disconnect the tools.

10. **Note:** If the machine had a Function Upgrade Card before downloading the software, be sure to put the card back in the slot before switching on.

11. Turn the machine back on.

12. Erase the SAF memory data using service function 07 - 2.

13. Print the system parameter list to check the new ROM version.



## 1.26 SOFTWARE UPLOAD (FUNCTION 16)

This procedure copies software from the FCU inside the machine to an external FCU.

### ⚠ CAUTION

If the machine has an optional Function Upgrade Card, change bit 7 of the System Switch 1E to "1", before removing the card, or the programmed data on the card may be lost.

Be sure to put it back to zero before step 11 below, otherwise the fax unit will not start up without the card installed.

1. Turn off the machine's ac switch.
2. Remove the IC card guiderails ([A] and [B]) from the FCU.

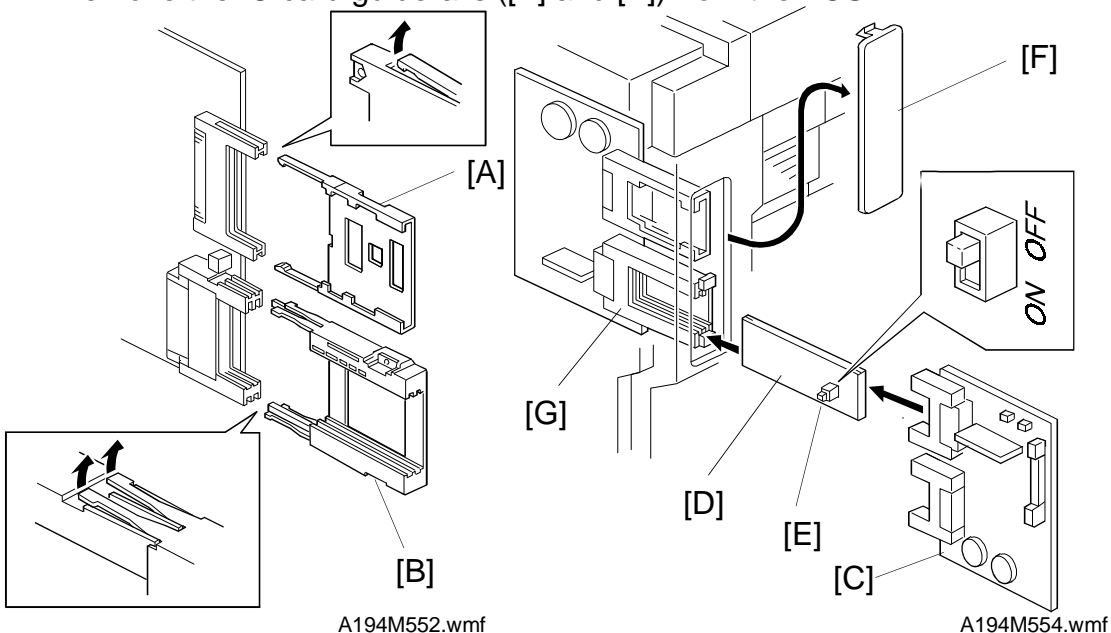

Service  
Tables and  
Procedures

3. Connect the target FCU [C] to the data copy tool [D], and make sure that the switch [E] on the data copy tool [D] is off.
4. Remove the cover [F]. Insert the copy tool [D] in the lower left slot [G].

5. Turn on the machine's ac and main switches, then enter fax service mode.

6. Press **1** **6**

7. Press **1** then **◊**

If the software has been successfully uploaded, the display shows 'OK'. Otherwise, the display shows 'NG'.

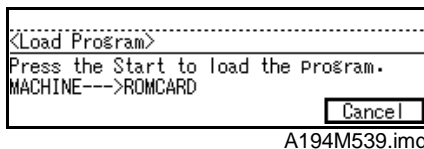
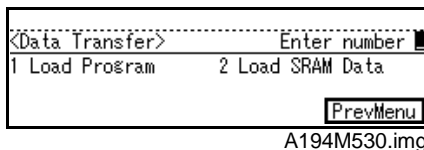



8. Exit the service mode.

9. Turn off the ac and main switches, then disconnect the tools.

**Note:** If the machine had a Function Upgrade Card before uploading the software, be sure to put the card back in the slot before switching on.

10. Turn the machine back on.

## 1.27 SRAM DATA DOWNLOAD (FUNCTION 16)

This procedure copies the SRAM data from an external FCU to the machine's FCU. Use this procedure after replacing the FCU, to save any previous settings.

### **⚠ CAUTION**

**If the machine has an optional Function Upgrade Card, change bit 7 of the System Switch 1E to "1", before removing the card, or the programmed data on the card may be lost.**

**Be sure to put it back to zero before step 10 below, otherwise the fax unit will not start up without the card installed.**

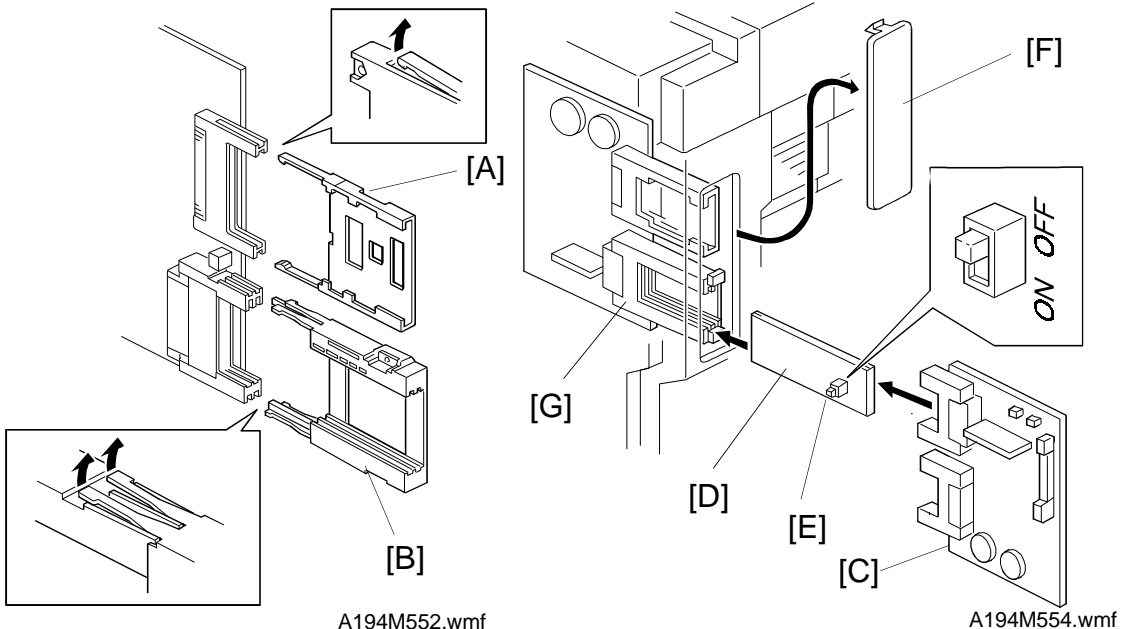

1. Turn off the machine's ac switch.

2. Remove the IC card guiderails ([A] and [B]) from the FCU.

3. Connect the old FCU [C] to the data copy tool [D], and make sure that the switch [E] on the data copy tool [D] is off.

3. Remove the cover [F], and insert the copy tool [D] in the lower left slot [G].
4. Turn on the machine's ac and main switches, then enter the fax service mode.

5. Press **1** **6**

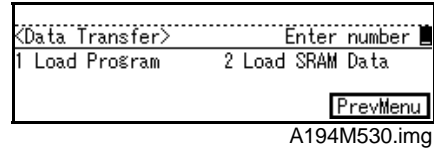

6. Press **2**

Then **◊** and **◊** simultaneously

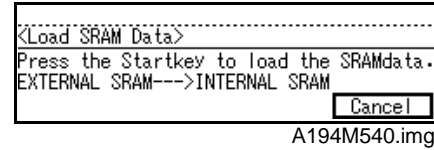

If the software has successfully been downloaded, the display shows 'OK'. Otherwise, the display shows 'NG'.

7. Exit the service mode.
8. Turn off the ac and main switches, then disconnect the tools.
9. **Note:** If the machine had a Function Upgrade Card, be sure to put the card back in the slot before turning the machine on.
10. Turn the machine back on.
11. Print the system parameter list to check if the previous settings have been successfully recovered.

## 2. BIT SWITCHES

### ⚠ WARNING

Do not adjust a bit switch that is described as "Not used", as this may cause the machine to malfunction or to operate in a manner that is not accepted by local regulations. Such bits are for use only in other areas, such as Japan.

**Note:** Default settings for bit switches are not listed in this manual. Refer to the System Parameter List printed by the machine.

### 2.1 SYSTEM SWITCHES

| System Switch 00  |   |   |
|---|---|---|
| No  | FUNCTION  | COMMENTS  |
| 0<br>1  | Not used.   | Do not change the settings.   |
| 2   | Technical data printout on the TCR (Journal)<br>0: Disabled<br>1: Enabled | 1: Instead of the personal code, the following data are listed on the TCR for each analog G3 communication.<br>e.g. V33 14 01 03 00 02<br><b>First number:</b> Final modem type used<br><b>Second number:</b> Final modem rate (for example, 14 means 14.4 kbps)<br><b>Third and fourth numbers:</b> Line quality data. Either a measure of the error rate or the rx level is printed, depending on the bit 3 setting below. (An M on the report indicates that it is error rate, and an L indicates Rx level.) The left hand figure is the low byte and the right hand figure is the high byte (refer to the following note for how to read the rx level). If it is a measure of the error rate; a larger number means more errors.<br><b>Fifth number (rx mode only):</b> Total number of error lines that occurred during non-ECM reception.<br><b>Sixth number (rx mode only):</b> Total number of burst error lines that occurred during non-ECM reception.<br>The fifth and sixth numbers are fixed at 00 for transmission records and ECM reception records. |
| <p><b>How to calculate the rx level listed on the TCR (Journal)</b></p> <p><b>Example:</b> V29 96 L <u>01</u> <u>A0</u> 00 00</p> <p>The four-digit hexadecimal value (N) after "L" indicates the rx level.<br/>The <u>high</u> byte is given first, followed by the <u>low</u> byte. Divide the decimal value of N by -16 to get the rx level.</p> <p>In the above example, the decimal value of N (= 01A0 [H]) is 416.<br/>So, the actual rx level is <math>416/-16 = -26</math> dB</p> |   |   |

| <b>System Switch 00</b> |   |  |
|-------------------------|---|--|
| <b>No</b>               | <b>FUNCTION</b>   | <b>COMMENTS</b>  |
| <b>3</b>                | Line quality data output method<br><b>0:</b> Measure of error rate (during image data transmission only)<br><b>1:</b> Rx level  | This bit determines the data type to be printed on the TCR (Journal) when technical data printout is enabled by bit 2 above.   |
| <b>4</b>                | Line error marks on received pages<br><b>0:</b> Disabled<br><b>1:</b> Enabled   | If this bit is 1, a mark will be printed on the left edge of the page at any place where a line error occurred in the data. Such errors are caused by a noisy line, for example.                               |
| <b>5</b>                | G3/G4 Communication parameter display<br><b>0:</b> Disabled<br><b>1:</b> Enabled  | This is a fault-finding aid. The LCD shows the key parameters (see the next 2 pages). This is normally disabled because it cancels the CSI display for the user. Be sure to reset this bit to 0 after testing. |
| <b>6</b>                | Protocol dump list output after each communication<br><b>0:</b> Off <b>1:</b> On  | This is only used for communication troubleshooting. It shows the content of the transmitted facsimile protocol signals. Always reset this bit to 0 after finishing testing.                                   |
| <b>7</b>                | Amount of protocol dump data in one protocol dump list printout operation<br><b>0:</b> Up to the limit of the memory area for protocol dumping<br><b>1:</b> Last communication only | Change this bit to 1 if you want to have a protocol dump list of the last communication only.  |

**G3 Communication Parameters**

|                     |   |
|---------------------|---|
| Modem rate          | 144: 14400 bps<br>120: 12000 bps<br>96: 9600 bps<br>72: 7200 bps<br>48: 4800 bps<br>24: 2400 bps  |
| Resolution          | S: Standard (8 x 3.85 dots per mm)<br>D: Detail (8 x 7.7 dots per mm)<br>F: Fine (8 x 15.4 dots per mm)<br>SF: Superfine (16 x 15.4 dots per mm) - optional Page Memory card required.<br>21: Standard (200 x 100 dpi)<br>22: Detail (200 x 200 dpi)<br>44: Superfine (400 x 400 dpi) - optional Page Memory card required. |
| Compression mode    | MMR: MMR compression<br>MR: MR compression<br>MH: MH compression  |
| Communication mode  | ECM: With ECM<br>SSC: Using SSC<br>EFC: Using EFC<br>NML: With no ECM, SSC, or EFC  |
| Width and reduction | A4: A4 (8.3"), no reduction<br>B4: B4 (10.1"), no reduction<br>A3: A3 (11.7"), no reduction   |
| I/O rate            | 0: 0 ms/line<br>25: 2.5 ms/line<br>5: 5 ms/line<br>10: 10 ms/line<br>20: 20 ms/line<br>40: 40 ms/line<br><b>Note:</b><br>"40" is displayed while receiving a fax message using AI short protocol.   |

**G4 Communication Parameters**

|                     |  |
|---------------------|--|
| Compression mode    | MMR: MMR compression<br>MR: MR compression<br>MH: MH compression   |
| Resolution          | 21: Standard (200 x 100 dpi)<br>22: Detail (200 x 200 dpi)<br>44: Superfine (400 x 400 dpi) - optional Page Memory card required.  |
| Width and reduction | A4: A4 (8.3"), no reduction<br>B4: B4 (10.1"), no reduction<br>A3: A3 (11.7"), no reduction  |
| Transfer            | T: Transfer<br>- : Other   |
| Confidential        | C: Confidential<br>- : Other   |
| Other parameters    | The following information is shown in 6-bit format. Bit 1 is the first bit from the left, and bit 6 is at the right end.<br>Bit 1 - Smoothing                   0: Enabled, 1: Disabled<br>(Smoothing is disabled in halftone mode.)<br>Bit 2 - CIL printing                0: Enabled, 1: Disabled<br>Bit 3 - Not used<br>Bit 4 - mm/inch conversion    0: Disabled, 1: Enabled<br>Bit 5 - Engine type            0: mm, 1: inch<br>Bit 6 - Resolution unit        0: mm, 1: inch |

| <b>System Switch 01</b> |  |   |
|-------------------------|--|---|
| <b>No</b>               | <b>FUNCTION</b>                                    | <b>COMMENTS</b>   |
| <b>0</b>                | PM call<br><b>0:</b> Disabled<br><b>1:</b> Enabled | This bit switch determines whether the machine will send an Auto Service Call to the service station when it is time for PM.<br><b>Cross reference</b><br>Auto service calls: Section 2.1 |
| <b>1-7</b>              | Not used   | Do not change the settings.   |

**Service Tables and Procedures**

| System Switch 02 |   |   |
|------------------|---|---|
| No               | FUNCTION  | COMMENTS  |
| 0<br>to<br>5     | Not used  | Do not change the settings.   |
| 6<br><br>7       | Memory read/write by RDS<br><b>Bit 7 6 Setting</b><br>0 0 Always disabled<br>0 1 User selectable<br>1 0 User selectable<br>1 1 Always enabled | <p><b>(0,0):</b> All RDS systems are always locked out.</p> <p><b>(0,1), (1,0):</b> Normally, RDS systems are locked out, but the user can temporarily switch RDS on to allow RDS operations to take place. RDS will automatically be locked out again after a certain time, which is stored in System Switch 03 (see below). Note that if an RDS operation takes place, RDS will not switch off until this time limit has expired.</p> <p><b>(1,1):</b> At any time, an RDS system can access the machine.</p> |

| System Switch 03 |   |   |
|------------------|---|---|
| No               | FUNCTION  | COMMENTS  |
| 0<br>to<br>7     | Length of time that RDS is temporarily switched on when bits 6 and 7 of System Switch 02 are set to "User selectable" | 00 - 99 hours (BCD).<br><br>This data is only valid if bits 6 and 7 of System Switch 02 are set to "User selectable".<br>The default setting is 24 hours. |

| System Switch 04 |   |   |
|------------------|---|---|
| No               | FUNCTION  | COMMENTS  |
| 0<br>to<br>2     | Not used  | Do not change the settings.   |
| 3                | Printing dedicated tx parameters on Quick/Speed Dial Lists<br><b>0:</b> Disabled<br><b>1:</b> Enabled | <p><b>1:</b> Each Quick/Speed dial number on the list is printed with the dedicated tx parameters (8 bytes each). The first 8 bytes of data are the programmed dedicated tx parameters, even though 32 bytes of data are printed (the other 24 bytes have no use in the field).</p> |
| 4                | Not used  | Do not change the settings.   |

| <b>System Switch 04</b> |  |   |
|-------------------------|--|---|
| <b>No</b>               | <b>FUNCTION</b>  | <b>COMMENTS</b>   |
| <b>5</b>                | Memory file transfer operation<br><b>0:</b> Service level<br><b>1:</b> User level          | If the machine is unable to print fax messages due to a mechanical problem, change this bit to 1 to transfer all messages in the memory (including confidential rx messages) to an another terminal.<br>Always reset this bit to zero after transfer. However, this bit can be left at 1, only if the customer's key-operator wants to transfer the files by himself.<br><b>Procedure</b><br>1. Enter the service mode and change this bit to 1.<br>2. Exit the service mode.<br>3. Enter the key-operator mode, and select 'Key-operator settings'.<br>4. Choose '03' and specify a destination for the machine to transfer all the files to.<br>5. Press 'OK'.<br>6. After the machine transfers the memory files, enter the service mode and reset this bit to 0.<br>Otherwise, anybody who knows how to enter the key-operator mode can transfer confidential messages. |
| <b>6</b>                | G3 CSI/G4 Terminal ID programming level<br><b>0:</b> User level<br><b>1:</b> Service level | <b>1:</b> The CSI and Terminal ID can only be programmed using a service function.<br>The Terminal ID can only be programmed if a Group 4 option is installed.  |
| <b>7</b>                | Telephone line type programming mode<br><b>0:</b> User level<br><b>1:</b> Service level    | <b>1:</b> Telephone line type selection (tone dial or pulse dial) can only be programmed using a service function.  |

| <b>System Switch 05</b> |  |   |
|-------------------------|--|---|
| <b>No</b>               | <b>FUNCTION</b>  | <b>COMMENTS</b>   |
| <b>0</b><br><b>1</b>    | Not used   | Do not change the settings.   |
| <b>2</b>                | Display of both RTI and CSI on the LCD<br><b>0:</b> Disabled <b>1:</b> Enabled | <b>1:</b> An RTI will be displayed until phase B of the protocol sequence, and a CSI will be displayed after phase C. |
| <b>3</b>                | Not used   | Do not change the settings.   |
| <b>4</b>                | Hard disk option<br><b>0:</b> Not installed<br><b>1:</b> Installed             | Change this bit to 1 when installing the hard disk option.  |
| <b>5</b>                | Not used   | Do not change the settings.   |
| <b>6</b>                |  |   |
| <b>7</b>                |  |   |



|  |
|--|
| <b>System Switch 06</b> - Not used (Do not change the factory settings.) |
| <b>System Switch 07</b> - Not used (Do not change the factory settings.) |
| <b>System Switch 08</b> - Not used (Do not change the factory settings.) |

| <b>System Switch 09</b> |   |  |
|-------------------------|---|--|
| <b>No</b>               | <b>FUNCTION</b>   | <b>COMMENTS</b>  |
| <b>0</b>                | Addition of part of the image data from confidential transmissions on the transmission result report<br><b>0:</b> Disabled <b>1:</b> Enabled                                    | If this feature is enabled, the top half of the first page of confidential messages will be printed on transmission result reports.  |
| <b>1</b>                | Inclusion of communications on the TCR when no image data was exchanged.<br><b>0:</b> Disabled <b>1:</b> Enabled  | <b>0:</b> Communications which reached phase C (message tx/rx) of the T.30 protocol are listed on the TCR (Journal).<br><b>1:</b> Communications which reached phase A (call setup) of T.30 protocol are listed on the TCR (Journal). This will include telephone calls. |
| <b>2</b>                | Automatic error report printout<br><b>0:</b> Disabled <b>1:</b> Enabled   | <b>0:</b> Error reports will not be printed.<br><b>1:</b> Error reports will be printed automatically after failed communications.   |
| <b>3</b>                | Printing of the error code on the error report<br><b>0:</b> No <b>1:</b> Yes  | <b>1:</b> Error codes are printed on the error reports.  |
| <b>4</b>                | Not used  | Do not change the settings.  |
| <b>5</b>                | Power failure report<br><b>0:</b> Disabled <b>1:</b> Enabled  | <b>1:</b> A power failure report will be automatically printed after the power is switched on if a fax message disappeared from the memory when the power was turned off last.   |
| <b>6</b>                | Not used  | Do not change the settings.  |
| <b>7</b>                | Priority given to various types of remote terminal ID when printing reports<br><b>0:</b> RTI > CSI > Dial label > Tel. number<br><b>1:</b> Dial label > Tel. number > RTI > CSI | This bit determines which set of priorities the machine uses when listing remote terminal names on reports. In G4 communication, G4_TID (Terminal ID) is used instead of RTI or CSI.<br><br>Dial Label: The name stored, by the user, for the Quick/Speed Dial number.   |

| <b>System Switch 0A</b>          |   |   |
|----------------------------------|---|---|
| <b>No</b>                        | <b>FUNCTION</b>   | <b>COMMENTS</b>   |
| <b>0</b><br><b>1</b><br><b>2</b> | Not used  | Do not change the settings.   |
| <b>3</b>                         | Continuous polling reception<br><b>0:</b> Disabled <b>1:</b> Enabled  | This feature allows a series of stations to be polled in a continuous cycle. This will continue until the polling reception file is erased.<br>The dialing interval is the same as memory transmission.   |
| <b>4</b>                         | Dialing on the ten-key pad when the external telephone is off-hook<br><b>0:</b> Disabled <b>1:</b> Enabled                | <b>0:</b> Prevents dialing from the ten-key pad while the external telephone is off-hook. Use this setting when the external telephone is not by the machine, or if a wireless telephone is connected as an external telephone.<br><b>1:</b> The user can dial on the machine's ten-key pad when the handset is off-hook. |
| <b>5</b>                         | On hook dial<br><b>0:</b> Disabled <b>1:</b> Enabled  | <b>0:</b> On hook dial is disabled.   |
| <b>6</b>                         | Line used for G3 transmission<br><b>0:</b> PSTN <b>1:</b> ISDN  | If an ISDN unit has been installed, this bit determines whether G3 transmissions go out over the PSTN or the ISDN.  |
| <b>7</b>                         | Line used when the machine falls back to G3 from G4 if the other end is not a G4 machine<br><b>0:</b> PSTN <b>1:</b> ISDN | This bit switch has no effect if Communication Switch 07 bit 0 is set to 0.   |

**System Switch 0B** - Not used (Do not change the factory settings.)

**System Switch 0C** - Not used (Do not change the factory settings.)

**System Switch 0D** - Not used (Do not change the factory settings.)

| <b>System Switch 0E</b>           |   |  |
|-----------------------------------|---|--|
| <b>No</b>                         | <b>FUNCTION</b>   | <b>COMMENTS</b>  |
| <b>0</b><br><b>1</b><br><b>2</b>  | Not used  | Do not change the settings.  |
| <b>3</b>                          | Action when the external handset goes off-hook<br><b>0:</b> Manual tx and rx operation<br><b>1:</b> Memory tx and rx operation (the display remains the same) | <b>0:</b> Manual tx and rx are possible while the external handset is off-hook. But, memory tx is not possible.<br><b>1:</b> The display stays in standby mode even when the external handset is used, so that other people can use the machine for memory tx operation.<br>Note that manual tx and rx are not possible with this setting. |
| <b>4</b><br><b>to</b><br><b>7</b> | Not used  | Do not change the settings.  |



| System Switch 0F                  |   |  |
|-----------------------------------|---|--|
| No                                | FUNCTION  | COMMENTS   |
| <b>0</b><br><b>to</b><br><b>7</b> | Country code for functional settings (Hex)<br><br>00: France      10: Not used<br>01: Germany    11: USA<br>02: UK            12: Asia<br>03: Italy          13: Japan<br>04: Austria     14: Hong Kong<br>05: Belgium    15: South Africa<br>06: Denmark    16: Australia<br>07: Finland     17: New Zealand<br>08: Ireland     18: Singapore<br>09: Norway     19: Malaysia<br>0A: Sweden    1A: China<br>0B: Switz.     1B: Taiwan<br>0C: Portugal    20: Turkey<br>0D: Holland    21: Greece<br>0E: Spain<br>0F: Israel | This country code determines the factory settings of bit switches and RAM addresses. However, it has no effect on the NCU parameter settings and communication parameter RAM addresses.<br><br><b>Cross reference</b><br>NCU country code: Function 06, parameter C.C. |

| System Switch 10                  |   |  |
|-----------------------------------|---|--|
| No                                | FUNCTION  | COMMENTS   |
| <b>0</b><br><b>to</b><br><b>7</b> | Threshold memory level for parallel memory transmission | Threshold = N x 64 kbytes + 256 kbytes<br>N can be between 00 - FF(H)<br>Default setting: 04(H) = 512 kbytes |

| System Switch 11                  |   |   |
|-----------------------------------|---|---|
| No                                | FUNCTION  | COMMENTS  |
| <b>0</b>                          | TTI printing position<br><b>0</b> : Superimposed on the page data<br><b>1</b> : Printed before the data leading edge                  | Change this bit to 1 if the TTI overprints information that the customer considers to be important (G3 transmissions).  |
| <b>1</b>                          | TSI (G3) or CIL (G4) printing position<br><b>0</b> : Printed before the data leading edge<br><b>1</b> : Superimposed on the page data | Change this bit to 1 if the TSI (G3) or CIL (G4) overprints information that the customer considers to be important.  |
| <b>2</b><br><b>to</b><br><b>6</b> | Not used  | Do not change the factory settings.   |
| <b>7</b>                          | Use of parallel memory transmission with G4 transmission<br><b>0</b> : Disabled<br><b>1</b> : Enabled                                 | This determines whether parallel transmission can be used with a G4 transmission or not. Note that this bit is only effective if Parallel Memory transmission is enabled (User Parameter 07 - bit 2). Refer to Parallel Memory Transmission in section 2. |

| <b>System Switch 12</b> |   |   |
|-------------------------|---|---|
| <b>No</b>               | <b>FUNCTION</b>   | <b>COMMENTS</b>   |
| <b>0 to 7</b>           | TTI/CIL printing position in the main scan direction<br><br>CIL: Command Information Line (Group 4) | 08 to 92 (BCD) mm. Input even numbers only.<br>This setting determines the print start position for the TTI and CIL from the left edge of the paper. If the TTI is moved too far to the right, it may interfere with the file number which is on the top right of the page. On an A4 page, if the CIL is moved over by more than 60 mm, it may overwrite the page number. |

|   |
|---|
| <b>System Switch 13</b> - Not used (do not change the settings) |
| <b>System Switch 14</b> - Not used (do not change the settings) |
| <b>System Switch 15</b> - Not used (do not change the settings) |
| <b>System Switch 16</b> - Not used (do not change the settings) |
| <b>System Switch 17</b> - Not used (do not change the settings) |
| <b>System Switch 18</b> - Not used (do not change the settings) |
| <b>System Switch 19</b> - Not used (do not change the settings) |
| <b>System Switch 1A</b> - Not used (do not change the settings) |
| <b>System Switch 1B</b> - Not used (do not change the settings) |
| <b>System Switch 1C</b> - Not used (do not change the settings) |
| <b>System Switch 1D</b> - Not used (do not change the settings) |

| <b>System Switch 1E</b> |   |  |
|-------------------------|---|--|
| <b>No</b>               | <b>FUNCTION</b>   | <b>COMMENTS</b>  |
| <b>0</b>                | Communication after the TCR (Journal) data storage area has become full<br><b>0</b> : Possible<br><b>1</b> : Impossible       | <b>0</b> : If the buffer memory of the communication records for the TCR (Journal) has become full, fax communications are still possible. But the the machine will overwrite the communication records from the oldest.<br><b>1</b> : If the buffer memory of the communication records for the TCR (Journal) has become full, fax communications will become impossible, in order not to overwrite the communication records before the machine prints them out.<br><br>Number of communication records for TCR (Journal):<br>256 records (without function upgrade card)<br>1000 records (with function upgrade card) |
| <b>1</b>                | Action when the SAF memory has become full while scanning<br><b>0</b> : The page is erased.<br><b>1</b> : The file is erased. | <b>0</b> : If the SAF memory becomes full while scanning, the successfully scanned pages are transmitted.<br><b>1</b> : If the SAF memory becomes full while scanning, the file is erased and no pages are transmitted.  |
| <b>2</b>                | RTI/CSI display priority<br><b>0</b> : RTI <b>1</b> : CSI   | This bit determines which identifier, RTI or CSI, is displayed on the LCD while the machine is communicating in G3 non-standard mode.  |





| System Switch 1E |  |   |
|------------------|--|---|
| No               | FUNCTION   | COMMENTS  |
| 3<br>to<br>5     | Not used   | Do not change the factory settings.   |
| 6                | Changing communication mode of programmed Quick/Speed dials from G4 to G3 after a G4 to G3 fallback<br><b>0:</b> Enabled<br><b>1:</b> Disabled | <b>0:</b> When bit 0 of Communication Switch 07 is enabled, the machine falls back from G4 to G3 after it receives a CPS code preprogrammed as a condition for G4 to G3 fallback.<br>If this happens, the machine permanently changes the communication mode of the Quick/Speed dial and Redials the number as G3.<br><b>1:</b> The machine starts with G4 communication even if a G4 to G3 fallback has occurred in previous transmissions.  |
| 7                | RAM initialization after a function upgrade card is installed or removed<br><b>0:</b> Enabled<br><b>1:</b> Disabled                            | When the machine detects that a function upgrade card has been installed or removed, the machine shows the following message on the display for the customer.<br><br><i>"CAUTION! Adding/Removing Memory Card results in data loss. Turn off the main switch and replace the card to cancel. If you want to continue, press Yes."</i><br><br>If Yes is pressed, the machine initializes the RAM to the "with" or "without card" configuration. However, changing this bit to '1' disables this initialization, even if Yes is pressed.<br><br>Change this bit to 1 before doing any operations which require the function upgrade card to be removed. (e.g. FCU replacement, Software download, etc.)<br><br><b>0:</b> When the above message is displayed, the machine initializes the RAM if Yes is pressed. The amount of data lost depends on whether the card is in or out (see Installation - IC Card). To avoid losing data, the user must switch off immediately and put the card back in.<br><b>1:</b> When the above message is displayed, the machine does not initialize the RAM even if Yes is pressed. However, the fax unit cannot be used until the user switches off, puts the card back in, then switches back on. No data is lost. |



| <b>System Switch 1F</b> |  |   |
|-------------------------|--|---|
| <b>No</b>               | <b>FUNCTION</b>  | <b>COMMENTS</b>   |
| <b>0<br/>to<br/>2</b>   | Not used   | Do not change the settings.   |
| <b>3</b>                | Received fax print start timing (G3 reception)<br><b>0:</b> After receiving each page<br><b>1:</b> After receiving all pages | <b>0:</b> The machine prints each page immediately after the machine receives it.<br><b>1:</b> The machine prints the complete message after the machine receives all the pages in the memory.  |
| <b>4</b>                | Received fax print start timing (G4 reception)<br><b>0:</b> After receiving each page<br><b>1:</b> After receiving all pages |   |
| <b>5<br/>6</b>          | Not used   | Do not change the factory settings.   |
| <b>7</b>                | Action when a fax SC has occurred<br><b>0:</b> Automatic reset<br><b>1:</b> SC code display                                  | <b>0:</b> When the fax unit detects a fax SC code other than SC1201 and SC1701, the fax unit automatically resets itself.<br><b>1:</b> When the fax unit detects any fax SC code, the fax unit displays the SC code and stops.<br><br>Cross Reference<br>Fax SC codes - See "Troubleshooting" |

## 2.2 SCANNER SWITCHES

| Scanner Switch 00     |   |  |
|-----------------------|---|--|
| No                    | FUNCTION  | COMMENTS   |
| <b>0<br/>to<br/>3</b> | Not used  | Do not change the settings.  |
| <b>4</b>              | OR processing for immediate tx<br><b>0:</b> Disabled<br><b>1:</b> Enabled | This switch is only effective when the scanner and the IPU of the base copier machine work together to get a required resolution.<br><b>0:</b> Every other line is skipped<br><b>1:</b> Two consecutive lines are OR-processed<br><br>Cross Reference<br>See "Original Scan Process" in chapter 2. |
| <b>5<br/>to<br/>7</b> | Not used  | Do not change the settings.  |

| Scanner Switch 01     |                                     |  |
|-----------------------|-------------------------------------|--|
| No                    | FUNCTION                            | COMMENTS   |
| <b>0<br/>to<br/>4</b> | Scan density step value (Text mode) | When scan density is adjusted manually away from the Normal setting, the threshold value for binary picture processing changes for each step from the value specified by Scanner Switch 02, by the amount programmed here.<br>For example, with the default settings (15), the threshold value changes as follows .<br>+3 (Darkest) : 83 (=98 - 15)<br>+2 : 98 (=113 - 15)<br>+1 : 113 (=128 - 15)<br>0 (Normal) : 128 (Scanner Switch 02 setting)<br>-1 : 143 (=128 + 15)<br>-2 : 158 (=143 + 15)<br>-3 (Lightest) : 173 (=158 + 15)<br><br>The value can be between 00 and 1F (H) [= 31(D)].<br>For a darker threshold, input a lower value.<br>Default setting - 15 |
| <b>5<br/>to<br/>7</b> | Not used.                           | Do not change the settings.  |

| Scanner Switch 02 |  |  |
|-------------------|--|--|
| No                | FUNCTION   | COMMENTS   |
| 0<br>to<br>7      | Binary picture processing:<br>Threshold for Text mode -<br>Normal setting (center<br>position) | This setting determines the threshold value for binary picture processing in Text mode, when the scan density setting is at the center.<br>The value can be between 00 and FF. For a darker threshold, input a lower value.<br>Default setting - 90(H)=144(D)<br><br>This setting is independent from the threshold setting specified by the copier's SP mode 4-418-1. |

| Scanner Switch 03 |  |   |
|-------------------|--|---|
| No                | FUNCTION   | COMMENTS  |
| 0<br>to<br>7      | Binary picture processing:<br>Threshold for Text/Photo<br>mode - Normal setting<br>(center position) | This setting determines the threshold value for binary picture processing in Text/Photo mode, when the scan density setting is at the center.<br>The value can be between 00 and 0F. For a darker threshold, input a lower value.<br>Default setting - 26(H)=38(D)<br><br>This setting is independent from the threshold setting specified by the copier's SP mode 4-418-2. |

**Scanner Switch 04 - Not used (Do not change the settings).**

| Scanner Switch 05 |   |   |
|-------------------|---|---|
| No                | FUNCTION  | COMMENTS  |
| 0<br>to<br>3      | MTF setting (Text mode)<br>The value can be between 0 and 11. Refer to the following diagram for how to adjust the setting.<br>Default setting - 4 (Do not use the setting '5'.)<br><br>This setting is independent from the threshold specified by copier SP mode 4-407. | <p>Weak Main-Scan Direction Strong</p> <p>0 → 1 → 2 → 3 → 4 → 5 → 8 → A</p> <p>Sub-Scan Direction Weak Strong</p> <p>6 9 B</p> <p>7</p> <p>Do not use this setting.</p> |
| 4<br>to<br>7      | Not used  | Do not change the settings. <span style="float: right;">A194M557.wmf</span>   |

Service Tables and Procedures



| <b>Scanner Switch 06</b> |                               |   |
|--------------------------|-------------------------------|---|
| <b>No</b>                | <b>FUNCTION</b>               | <b>COMMENTS</b>   |
| <b>0<br/>to<br/>3</b>    | MTF setting (Text/Photo mode) | The value can be between 0 to 11. Refer to Scanner Switch 05 for how to adjust the setting.<br>Default setting - 8 (Do not use the setting '5'.)<br><br>This setting is independent from the threshold setting specified by the copier's SP mode 4-407-5. |
| <b>4<br/>to<br/>7</b>    | Not used                      | Do not change the settings.   |

| <b>Scanner Switch 07</b> |                          |   |
|--------------------------|--------------------------|---|
| <b>No</b>                | <b>FUNCTION</b>          | <b>COMMENTS</b>   |
| <b>0<br/>to<br/>3</b>    | MTF setting (Photo mode) | The value can be between 0 and 11. Refer to the diagram on the previous page for how to adjust the setting.<br>Default setting - 1 (Do not use the setting '5'.)<br><br>This setting is independent from the threshold setting specified by the copier's SP mode 4-407-6. |
| <b>4<br/>to<br/>7</b>    | Not used                 | Do not change the settings.   |

| <b>Scanner Switch 08</b> |   |  |
|--------------------------|---|--|
| <b>No</b>                | <b>FUNCTION</b>   | <b>COMMENTS</b>  |
| <b>0<br/>to<br/>3</b>    | Scan margin setting (top and bottom margin in book scan mode, and top margin in ADF mode) | The setting can be between 0 and F (H) (in mm).<br>Default setting - 2 mm<br><br>If the scanned image is not what you expect after adjustment, the base copier's SP mode settings may be incorrect. Check and adjust SP modes 4-012-1, 4-012-2, and 6-006-2. |
| <b>4<br/>to<br/>7</b>    | Scan margin setting (bottom margin in ADF mode)   | The setting can be between 0 and F (H) (in mm).<br>Default setting - 2 mm<br><br>If the scanned image is not what you expect after adjustment, the base copier's SP mode settings may be incorrect. Check and adjust SP mode 6-006-3.                        |

**Scanner Switch 09** - Not used (do not change the settings)

**Scanner Switch 0A** - Not used (do not change the settings)

**Scanner Switch 0B** - Not used (do not change the settings)

| Scanner Switch 0C |  |  |
|-------------------|--|--|
| No                | FUNCTION   | COMMENTS   |
| 0                 | Action when an original jam has occurred while scanning the original into memory for memory tx<br><b>0:</b> Continues scanning after recovery<br><b>1:</b> Stops scanning and erases all scanned pages for that job. | This bit is only effective when parallel memory tx is disabled (user parameter 07 - bit 2).<br>If parallel memory tx is enabled, the machine always erases the scanned pages when an original jam occurs. The machine then asks the user to retry from the first page, even if the parallel memory tx is not actually used.<br><br><b>0:</b> The machine displays a message asking the user to put the jammed page back into the original stack, and continues scanning. The message is displayed for the time period specified by scanner switch 0E, bit 2.<br><b>1:</b> The machine erases all the scanned pages and asks the user to retry from the first page. |
| 1 to 7            | Not used   | Do not change the settings.  |

| Scanner Switch 0D |   |   |
|-------------------|---|---|
| No                | FUNCTION  | COMMENTS  |
| 0                 | Scan magnification ratio fine tuning (Main scan direction)  |   |
| 1                 | $\begin{pmatrix} 0 \\ 0 \end{pmatrix} = 0\%$ , $\begin{pmatrix} 1 \\ 0 \end{pmatrix} = -0.5\%$ , $\begin{pmatrix} 0 \\ 1 \end{pmatrix} = +0.5\%$ , $\begin{pmatrix} 1 \\ 1 \end{pmatrix} =$ Do not use this setting<br>The actual magnification ratio is the sum of the SP mode 4-008 setting and this setting. |   |
| 2                 | Scan magnification ratio fine tuning (Sub scan direction)   |   |
| 3                 | $\begin{pmatrix} 0 \\ 0 \end{pmatrix} = 0\%$ , $\begin{pmatrix} 1 \\ 0 \end{pmatrix} = -1.0\%$ , $\begin{pmatrix} 0 \\ 1 \end{pmatrix} = +1.0\%$ , $\begin{pmatrix} 1 \\ 1 \end{pmatrix} =$ Do not use this setting<br>The actual magnification ratio is the sum of the SP mode 4-101 setting and this setting. |   |
| 4 to 6            | Not used  | Do not change the settings.   |
| 7                 | Scan width for A5 lengthwise or B5 lengthwise original<br><b>0:</b> 210 mm (8.5")<br><b>1:</b> Original width   | <b>0:</b> The machine scans the original as 210 mm (8.5") width. The transmitted image has a blank area on the right.<br><b>1:</b> The machine scans 148 mm (A5) or 182 mm (B5) and centers the scanned data on a 216 mm width transmitted image. |

Service  
Tables and  
Procedures

| <b>Scanner Switch 0E</b> |   |  |
|--------------------------|---|--|
| <b>No</b>                | <b>FUNCTION</b>   | <b>COMMENTS</b>  |
| <b>0</b>                 | Wait time for the next page when scanning a book original into memory<br><b>0:</b> 60 s<br><b>1:</b> 30 s | This bit determines how long the machine waits for the next page when scanning a book original for memory transmission. If this timer expires, the machine transmits all the pages scanned so far as one document.<br><br><b>Note:</b> In immediate tx, the wait time for the next page is 15 s. |
| <b>1</b>                 | Scan resolution unit (except standard resolution in book scan mode)<br><b>0:</b> mm<br><b>1:</b> inch     | This bit determines which resolution unit will be used for scanning a fax message.<br><br>Default setting: mm  |
| <b>2</b>                 | ADF jam alarm display time<br><b>0:</b> 60 s<br><b>1:</b> 30 s  | The bit is only effective when bit 0 of scanner bit switch 0C is '0'.<br>This bit determines how long the machine displays the ADF jam alarm after a jam has happened.   |
| <b>3</b>                 | Scan resolution unit (standard resolution in book scan mode)<br><b>0:</b> mm<br><b>1:</b> inch            | This bit determines which resolution unit will be used for scanning a fax message, when standard resolution is selected in book scan mode.<br><br>Default setting: inch  |
| <b>4 to 7</b>            | Not used  | Do not change the settings.  |

| <b>Scanner Switch 0F</b> |   |  |
|--------------------------|---|--|
| <b>No</b>                | <b>FUNCTION</b>   | <b>COMMENTS</b>  |
| <b>0</b>                 | Image rotation before transmission<br><b>0:</b> Enabled<br><b>1:</b> Disabled | This bit determines whether the machine rotates the scanned image by 90 degrees before transmission. If this bit is set at 0, A4 (LT) sideways images (297 mm width in the protocol) will be transmitted as A4 (LT) lengthwise images (216 mm width in the protocol). Refer to Image Rotation Before Transmission in chapter 2 for more details. |
| <b>1 to 7</b>            | Not used  | Do not change the settings.  |

## 2.3 PRINTER SWITCHES

| Printer Switch 00 |  |   |
|-------------------|--|---|
| No                | FUNCTION   | COMMENTS  |
| 0                 | Page separation mark<br>0: Disabled<br>1: Enabled  | 0: No marks are printed.<br>1: If a received page has to be printed out on two sheets, an asterisk inside square brackets is printed at the bottom right hand corner of the first sheet, and a "2" inside a small box is printed at the top right hand corner of the second sheet. This helps the user to identify pages that have been split up. |
| 1                 | Repetition of data when the received page is longer than the printer paper<br>0: Disabled 1: Enabled | 0: The next page continues from where the previous page left off.<br>1: The final few mm of the previous page are printed at the top of the next page.<br>See Sub Scan Reduction and Page Separation in section 2 for details.  |
| 2                 | Prints date and time data on received fax messages<br>0: Disabled 1: Enabled                         | This switch is only effective when user parameter 02 - bit 2 (printing the received date and time on received fax messages) is enabled.<br>1: The machine prints received and printed date and time at the bottom of each received page.  |
| 3-6               | Not used   | Do not change the settings.   |
| 7                 | mm-inch recognition when printing<br>0: Disabled 1: Enabled  | 0: Printing is always done in inch format.<br>1: The machine switches the print resolution unit in accordance with the resolution unit of the received data, which has been specified in the setup protocol.<br>Refer to Sub Scan Reduction and Page Separation in section 2 for details.   |

| Printer Switch 01 |   |   |
|-------------------|---|---|
| No                | FUNCTION  | COMMENTS  |
| 0<br>1<br>2       | Not used  | Do not change the settings.   |
| 3<br>4            | Maximum print width used in the setup protocol.<br>$\begin{pmatrix} 0 \\ 0 \end{pmatrix}$ = Not used , $\begin{pmatrix} 1 \\ 0 \end{pmatrix}$ = 297 mm 11.7 inch , $\begin{pmatrix} 0 \\ 1 \end{pmatrix}$ = 254 mm 10.1 inch , $\begin{pmatrix} 1 \\ 1 \end{pmatrix}$ = 216 mm 8.5 inch |   |
| 5<br>6            | Not used  | Do not change the settings.   |
| 7                 | Received message width restriction in the protocol signal to the sender<br>0: Disabled<br>1: Enabled  | 0: The machine informs the transmitting machine of the print width depending on the paper size available from the paper feed stations.<br>Refer to the table on the next page for how the machine chooses the paper width used in the setup protocol (NSF/DIS).<br>1: The machine informs the transmitting machine of the fixed paper width which is specified by bits 3 and 4 above. |

## Relationship between available paper sizes and printer width used in the setup protocol

| Available Paper Size           | Printer width used in the Protocol (NSF/DIS) |
|--------------------------------|--|
| A4 or 8.5 x 11"                | 297 mm width                                 |
| B5                             | 256 mm width                                 |
| A5 or 8.5 x 5.5"               | 216 mm width                                 |
| No paper available (Paper end) | 216 mm width                                 |

| Printer Switch 02 |  |  |
|-------------------|--|--|
| No                | FUNCTION   | COMMENTS   |
| 0                 | 1st paper feed station usage for fax printing<br>0: Enabled<br>1: Disabled | <p>0: The paper feed station can be used to print fax messages and reports.</p> <p>1: The specified paper feed station will not be used for printing fax messages and reports.</p> <p><b>Note:</b> Do not disable usage for the paper feed station which has been specified by User Parameter Switch 0F (15), or which is used for the Specified Cassette Selection feature.</p> |
| 1                 | 2nd paper feed station usage for fax printing<br>0: Enabled<br>1: Disabled |  |
| 2                 | 3rd paper feed station usage for fax printing<br>0: Enabled<br>1: Disabled |  |
| 3                 | 4th paper feed station usage for fax printing<br>0: Enabled<br>1: Disabled |  |
| 4 to 7            | Not used   | Do not change the settings.  |

| Printer Switch 03 |  |  |
|-------------------|--|--|
| No                | FUNCTION   | COMMENTS   |
| 0                 | Length reduction of received data<br>0: Disabled<br>1: Enabled | <p>0: Incoming pages are printed without length reduction.</p> <p><b>Cross reference</b><br/>Page separation threshold: Printer Sw. 03, bits 4 to 7.</p> <p>1: Incoming pages are reduced in the length direction when printing.</p> <p><b>Cross reference</b><br/>Maximum reducible length: Printer Switches 04, bits 0 to 4<br/>Page separation and data reduction: chapter 2.</p> |
| 1                 | Not used   | Do not change the settings.  |
| 2                 |  |  |
| 3                 |  |  |

| Printer Switch 03 |   |
|-------------------|---|
| No                | FUNCTION COMMENTS   |
| 4                 | Page separation threshold (with reduction disabled in switch 03-0 above)  |
| to                | If the incoming page is up to x mm longer than the the length of copy paper, the excess portion will not be printed. If the incoming page is more than x mm longer than the |
| 7                 | length of copy paper, the excess portion will be printed on the next page.<br>The value of x is determined by these four bits.  |
|                   | Hex value of bits 4 to 7                      x (mm)  |
|                   | 0    0  |
|                   | 1    1  |
|                   | and so on until   |
|                   | F    15   |
|                   | Default setting: 6 mm   |
|                   | <b>Cross reference</b>  |
|                   | Page separation and data reduction: section 2   |
|                   | Length reduction On/Off: Printer Switch 03, Bit 0   |

| Printer Switch 04 |   |
|-------------------|---|
| No                | FUNCTION COMMENTS   |
| 0                 | Maximum reducible length when length reduction is enabled in switch 03-0 above.   |
| to                | <Maximum reducible length> = <Paper length> + (N x 5mm)   |
| 4                 | 'N' is the decimal value of the binary setting of bits 0 to 4.  |
|                   | Bit    4    3    2    1    0    Setting   |
|                   | 0    0    0    0    0    0 mm   |
|                   | 0    0    0    0    1    5 mm   |
|                   | 0    0    1    0    0    20 mm (default setting)  |
|                   | 1    1    1    1    1    155 mm   |
|                   | For A5 sideways and B5 sideways paper   |
|                   | <Maximum reducible length> = <Paper length> + 0.75 x (N x 5mm)  |
| 5                 | Length of the duplicated image on the next page, when page separation has taken place.  |
| 6                 | $\begin{pmatrix} 0 \\ 0 \end{pmatrix} = 4 \text{ mm}, \begin{pmatrix} 1 \\ 0 \end{pmatrix} = 10 \text{ mm}, \begin{pmatrix} 0 \\ 1 \end{pmatrix} = 20 \text{ mm}, \begin{pmatrix} 1 \\ 1 \end{pmatrix} = 40 \text{ mm}$ |
| 7                 | Not used.                                      Do not change the setting.   |

Service  
Tables and  
Procedures

|  |
|--|
| <b>Printer Switch 05</b> - Not used (do not change the settings) |
| <b>Printer Switch 06</b> - Not used (do not change the settings) |
| <b>Printer Switch 07</b> - Not used (do not change the settings) |
| <b>Printer Switch 08</b> - Not used (do not change the settings) |
| <b>Printer Switch 09</b> - Not used (do not change the settings) |
| <b>Printer Switch 0A</b> - Not used (do not change the settings) |
| <b>Printer Switch 0B</b> - Not used (do not change the settings) |
| <b>Printer Switch 0C</b> - Not used (do not change the settings) |
| <b>Printer Switch 0D</b> - Not used (do not change the settings) |

| <b>Printer Switch 0E</b> |  |   |
|--------------------------|--|---|
| <b>No</b>                | <b>FUNCTION</b>  | <b>COMMENTS</b>   |
| <b>0</b>                 | Paper size selection priority<br><b>0:</b> Width<br><b>1:</b> Length   | <b>0:</b> A paper size which has the same width as the received data is selected first.<br><b>1:</b> A paper size which has enough length to print all the received lines without reduction is selected first.  |
| <b>1</b>                 | Paper size selected for printing A4 width fax data<br><b>0:</b> 8 x 11" size<br><b>1:</b> A4 size                | This switch determines which paper size is selected for printing A4 width fax data, when the machine has A4 and 8" x 11" size paper at the same time.   |
| <b>2</b>                 | Page separation<br><b>0:</b> Enabled<br><b>1:</b> Disabled   | <b>1:</b> If all paper sizes in the machine require page separation to print a received fax message, the machine does not print the message (Substitute Reception is used).<br>After a larger size of paper is set in a cassette, the machine automatically prints the fax message. |
| <b>3 to 6</b>            | Not used   | Do not change the settings.   |
| <b>7</b>                 | Equalizing the reduction rate among separated pages (Page Separation)<br><b>0:</b> Enabled<br><b>1:</b> Disabled | <b>0:</b> All the pages are reduced with the same reduction ratio, when page separation has taken place.<br><b>1:</b> Only the last page is reduced to fit the selected paper size when the page separation has taken place. Other pages are printed without reduction.             |



| Printer Switches 0F |  |  |
|---------------------|--|--|
| No                  | FUNCTION   | COMMENTS   |
| 0<br>1              | Not used   | Do not change the setting.   |
| 2                   | Duplex printing<br>0: Disabled<br>1: Enabled   | 1: The machine prints received fax messages in duplex printing mode.<br><br><b>Cross Reference</b><br>"Duplex Printing" in chapter 2   |
| 3                   | Not used   | Do not change the setting.   |
| 4                   | Printing fax messages in Restricted Access mode<br>0: Enabled<br>1: Disabled   | 1: The machine holds the received fax messages until the machine exits the restricted access mode. If the machine enters the restricted access mode again while printing fax messages, the machine stops printing until the machine exits the mode again.<br><br><b>Cross reference</b><br>Restricted access on/off - Key operator mode 01-3 |
| 5                   | Not used   | Do not change the setting.   |
| 6                   | Wait timer for Duplex Print Mode.  |  |
| 7                   | $\begin{pmatrix} 0 \\ 0 \end{pmatrix} = \text{No limit}, \begin{pmatrix} 1 \\ 0 \end{pmatrix} = 1 \text{ min.}, \begin{pmatrix} 0 \\ 1 \end{pmatrix} = 3 \text{ min.}, \begin{pmatrix} 1 \\ 1 \end{pmatrix} = 10 \text{ min.}$ <p>If copy job or printer controller is using the duplex unit when the fax unit is going to print a fax message in duplex mode, the fax unit waits until the duplex unit becomes available. The time period that the fax unit will wait can be specified, as shown above. If the timer expires, the message is printed on single sides.</p> |  |



## 2.4 COMMUNICATION SWITCHES

| Communication Switch 00 |   |  |
|-------------------------|---|--|
| No                      | FUNCTION  | COMMENTS   |
| 0                       | Compression modes available in receive mode                                       | These bits determine the compression capabilities to be declared in phase B (handshaking) of the T.30 protocol.  |
| 1                       | <b>Bit 1 0 Modes</b><br>0 0 MH only<br>0 1 MH/MR<br>1 0 MH/MR/MMR<br>1 1 Not used |  |
| 2                       | Compression modes available in transmit mode                                      |  |
| 3                       | <b>Bit 3 2 Modes</b><br>0 0 MH only<br>0 1 MH/MR<br>1 0 MH/MR/MMR<br>1 1 Not used |  |
| 4 to 6                  | Not used  |  |
| 7                       | Closed network (reception)<br><b>0:</b> Disabled<br><b>1:</b> Enabled             | <b>1:</b> Reception will not go ahead if the ID code of the other terminal does not match the ID code of this terminal. This function is only available in NSF/NSS mode. |

| Communication Switch 01 |   |   |                            |
|-------------------------|---|---|----------------------------|
| No                      | FUNCTION  | COMMENTS  |                            |
| 0                       | ECM<br><b>0:</b> Off <b>1:</b> On   | If this bit is 0, ECM is switched off for all communications.   |                            |
| 1                       | EFC during transmission<br><b>0:</b> Off <b>1:</b> On                                       | If this bit is 0, EFC is switched off during transmission.  |                            |
| 2                       | Wrong connection prevention method  | <b>(0,1)</b> - The machine will disconnect the line without sending a fax message, if the last 8 digits of the received CSI do not match the last 8 digits of the dialed telephone number. This does not work when manually dialed.<br><b>(1,0)</b> - The same as above, except that only the last 4 digits are compared.<br><b>(1,1)</b> - The machine will will disconnect the line without sending a fax message, if the other end does not identify itself with an RTI or CSI.<br><b>(0,0)</b> - Nothing is checked; transmission will always go ahead.<br><br><b>Note:</b> This function does not work when dialing is done from the external telephone. |                            |
| 3                       | <b>Bit 3 Bit 2 Setting</b><br>0 0 None<br>0 1 8 digit CSI<br>1 0 4 digit CSI<br>1 1 CSI/RTI |   |                            |
| 4                       | Not used  |   |                            |
| 5                       | Not used  |   | Do not change the setting. |

| Communication Switch 01 |   |   |
|-------------------------|---|---|
| No                      | FUNCTION                                | COMMENTS  |
| 6                       | Maximum printable page length available | The setting determined by these bits is informed to the transmitting terminal in the pre-message protocol exchange (in the DIS/NSF frames). |
| 7                       | <b>Bit 7 Bit 6 Setting</b>              |   |
|                         | 0 0 No limit                            |   |
|                         | 0 1 B4 (364 mm)                         |   |
|                         | 1 0 A4 (297 mm)                         |   |
|                         | 1 1 A3 (432 mm)                         |   |

| Communication Switch 02 |  |  |
|-------------------------|--|--|
| No                      | FUNCTION   | COMMENTS   |
| 0                       | Burst error threshold<br><b>0:</b> Low <b>1:</b> High  | If there are more consecutive error lines in the received page than the threshold, the machine will send a negative response.<br>The Low and High threshold values depend on the sub-scan resolution, and are as follows.<br><b>Resolution</b> <b>100 dpi</b> <b>200 dpi</b> <b>400 dpi</b><br><b>3.85 l/mm</b> <b>7.7 l/mm</b> <b>15.4 l/mm</b><br>Low settings            3            6            12<br>High settings           6            12           24 |
| 1                       | Acceptable total error line ratio<br><b>0:</b> 5% <b>1:</b> 10%  | If the error line ratio for a page exceeds the acceptable ratio, RTN will be sent to the other end.  |
| 2                       | Treatment of pages received with errors during G3 reception<br><b>0:</b> Deleted from memory without printing<br><b>1:</b> Printed         | <b>0:</b> Pages received with errors are not printed.  |
| 3                       | Hang-up decision when a negative code (RTN or PIN) is received during G3 immediate transmission<br><b>0:</b> No hang-up, <b>1:</b> Hang-up | <b>0:</b> The next page will be sent even if RTN or PIN is received.<br><b>1:</b> The machine will send DCN and hang up if it receives RTN or PIN.<br><br>This bit is ignored for memory transmissions or if ECM is being used.  |
| 4 to 7                  | Not used   | Do not change the settings.  |

Service Tables and Procedures

| <b>Communication Switch 03</b> |  |  |
|--------------------------------|--|--|
| <b>No</b>                      | <b>FUNCTION</b>  | <b>COMMENTS</b>  |
| <b>0 to 7</b>                  | Maximum number of page retransmissions in a G3 memory transmission | 00 - FF (Hex) times.<br>This setting is not used if ECM is switched on.<br>Default setting - 03(H) |

|  |
|--|
| <b>Communication Switch 04</b> - Not used (do not change the settings) |
| <b>Communication Switch 05</b> - Not used (do not change the settings) |

| <b>Communication Switch 06</b> |  |  |
|--------------------------------|--|--|
| <b>No</b>                      | <b>FUNCTION</b>  | <b>COMMENTS</b>  |
| <b>0</b>                       | Dialing requirements: Germany<br><b>0: Disabled 1: Enabled</b>     | These switches are automatically set to the settings required by each country after a country code (System Switch 0F) is programmed. |
| <b>1</b>                       | Dialing requirements: Austria<br><b>0: Disabled 1: Enabled</b>     |  |
| <b>2</b>                       | Dialing requirements: Norway<br><b>0: Disabled 1: Enabled</b>      |  |
| <b>3</b>                       | Dialing requirements: Denmark<br><b>0: Disabled 1: Enabled</b>     |  |
| <b>4</b>                       | Dialing requirements: France<br><b>0: Disabled 1: Enabled</b>      |  |
| <b>5</b>                       | Dialing requirements: Switzerland<br><b>0: Disabled 1: Enabled</b> |  |
| <b>6</b>                       | Not used   | Do not change the settings.  |
| <b>7</b>                       |  |  |

| <b>Communication Switch 07</b> |  |   |
|--------------------------------|--|---|
| <b>No</b>                      | <b>FUNCTION</b>  | <b>COMMENTS</b>   |
| <b>0</b>                       | Fallback from G4 to G3 if the other terminal is not a G4 terminal<br><b>0: Disabled 1: Enabled</b> | Also see System Switch 0A bit 7.<br>Refer to the ISDN G4 option service manual (G4 Internal Switches 17, 18, 1A, 1B, and 1C) for the CPS code set (Cause Value set) to determine G4 to G3 fallback.                   |
| <b>1</b>                       | Not used   | Do not change the setting.  |
| <b>2</b>                       | Use of the date and time provided from the network for the CIL<br><b>0: Disabled 1: Enabled</b>    | <b>0:</b> The date and time programmed in the receiving terminal is used in the CIL.<br><b>1:</b> The date and time informed in the document layer from the remote terminal (through the network) is used in the CIL. |
| <b>3 to 7</b>                  | Not used   | Do not change the settings.   |

**Communication Switch 08** - Not used (do not change the settings.)

**Communication Switch 09** - Not used (do not change the settings.)

| <b>Communication Switch 0A</b> |   |  |
|--------------------------------|---|--|
| <b>No</b>                      | <b>FUNCTION</b>   | <b>COMMENTS</b>  |
| <b>0</b>                       | Point of resumption of memory transmission upon redialing<br><b>0:</b> From the error page<br><b>1:</b> From page 1 | <b>0:</b> The transmission begins from the page where transmission failed the previous time.<br><b>1:</b> Transmission begins from the first page, using normal memory transmission. |
| <b>1 to 6</b>                  | Not used  | Do not change the settings.  |
| <b>7</b>                       | Emergency calls using 999<br><b>0:</b> Enabled <b>1:</b> Disabled   | If this bit is at 1, the machine will not allow you to dial 999 at the auto-dialer. This is a PTT requirement in the UK and some other countries.                                    |

| <b>Communication Switch 0B</b> |   |   |
|--------------------------------|---|---|
| <b>No</b>                      | <b>FUNCTION</b>   | <b>COMMENTS</b>   |
| <b>0</b>                       | Use of Economy Transmission during a Transfer operation to end receivers<br><b>0:</b> Disabled <b>1:</b> Enabled                                | These bits determine whether the machine uses the Economy Transmission feature when it is carrying out a Transfer operation as a Transfer Station.  |
| <b>1</b>                       | Use of Economy Transmission during a Transfer operation to the Next Transfer Stations<br><b>0:</b> Disabled <b>1:</b> Enabled                   |   |
| <b>2</b>                       | Use of Label Insertion for the End Receivers in a Transfer operation<br><b>0:</b> Disabled <b>1:</b> Enabled                                    | This bit determines whether the machine uses the Label Insertion feature when it is carrying out a Transfer operation as a Transfer Station.  |
| <b>3</b>                       | Conditions required for Transfer Result Report transmission<br><b>0:</b> Always transmitted<br><b>1:</b> Only transmitted if there was an error | <b>0:</b> When acting as a Transfer Station, the machine will always send a Transfer Result Report back to the Requesting Station after completing the Transfer Request, even if there were no problems.<br><b>1:</b> The machine will only send back a Transfer Result Report if there were errors during communication so that one or more of the End Receivers could not be contacted. |
| <b>4</b>                       | Printout of the message when acting as a Transfer Station<br><b>0:</b> Disabled <b>1:</b> Enabled   | When the machine is acting as a Transfer Station, this bit determines whether the machine prints the fax message coming in from the Requesting Terminal.  |

| <b>Communication Switch 0B</b> |  |   |
|--------------------------------|--|---|
| <b>No</b>                      | <b>FUNCTION</b>  | <b>COMMENTS</b>   |
| <b>5</b>                       | Action when there is no fax number in the programmed Quick/Speed dials which meets the requesting terminal's own fax number<br><b>0:</b> Transfer is Disabled<br><b>1:</b> Transfer is Enabled | After the machine receives a transfer request, the machine compares the last N digits of the requesting terminal's own fax number with all the Quick/Speed dials programmed in the machine. (N is the number programmed in communication switch 0C.)<br><b>0:</b> If there is no matching number programmed in the machine, the machine rejects the transfer request.<br><b>1:</b> Even if there is no matching number programmed in the machine, the machine accepts the transfer request. The result report will be printed at the transfer terminal, but will not be sent back to the requesting terminal. Refer to "Transfer Broadcasting" in chapter 2 for more details. |
| <b>6</b>                       | Not used   | Do not change the settings.   |
| <b>7</b>                       |  |   |

| <b>Communication Switch 0C</b> |  |  |
|--------------------------------|--|--|
| <b>No</b>                      | <b>FUNCTION</b>  | <b>COMMENTS</b>  |
| <b>0 to 4</b>                  | Number of digits compared to find the requester's fax number from the programmed Quick/Speed Dials when acting as a Transfer Station | 00 - 1F (0 to 31 digits)<br>After the machine receives a transfer request, the machine compares the own telephone number sent from the Requesting Terminal with all Quick/Speed Dials programmed in the machine, starting from Quick Dial 01 to the end of the Speed Dials.<br>This number determines how many digits from the end of the telephone numbers the machine compares. If it is set to 00, the machine will send the report to the first Quick/Speed Dial that the machine compared. If Quick Dial 01 is programmed, the machine will send the report to Quick 01. If Quick Dial 01 through 04 are not programmed and Quick Dial 05 is programmed, the machine will send the report to Quick 05.<br>Default setting - 05(H) = 5 digits<br>Refer to "Transfer Broadcasting" in chapter 2 for more details. |
| <b>5 to 7</b>                  | Not used   | Do not change the settings.  |

| <b>Communication Switch 0D</b> |   |   |
|--------------------------------|---|---|
| <b>No</b>                      | <b>FUNCTION</b>   | <b>COMMENTS</b>   |
| <b>0 to 7</b>                  | The available memory threshold, below which ringing detection (and therefore reception into memory) is disabled | 00 to FF (Hex), unit = 2 kbytes<br>(e.g., 0C(H) = 24 kbytes)<br>One page is about 24 kbytes.<br><br>The machine refers to this setting before each fax reception. If the amount of remaining memory is below this threshold, the machine can not receive any fax messages.<br><br>If this setting is kept at 0, the machine will detect ringing signals and go into receive mode even if there is no memory available. This will result in communication failure. |

| <b>Communication Switch 0E</b> |   |   |
|--------------------------------|---|---|
| <b>No</b>                      | <b>FUNCTION</b>                                     | <b>COMMENTS</b>   |
| <b>0 to 7</b>                  | Minimum interval between automatic dialing attempts | 06 to FF (Hex), unit = 2 s<br>(e.g., 06(H) = 12 s)<br>This value is the minimum time that the machine waits before it dials the next destination. |

| <b>Communication Switch 0F</b> |   |                     |
|--------------------------------|---|---------------------|
| <b>No</b>                      | <b>FUNCTION</b>   | <b>COMMENTS</b>     |
| <b>0 to 7</b>                  | Minimum number of times that a destination will dialed when TRD is being used | 01 - FF (Hex) times |

| <b>Communication Switch 10</b> |   |                     |
|--------------------------------|---|---------------------|
| <b>No</b>                      | <b>FUNCTION</b>   | <b>COMMENTS</b>     |
| <b>0 to 7</b>                  | Memory transmission: Maximum number of dialing attempts to the same destination | 01 - FF (Hex) times |

**Communication Switch 11** - Not used (do not change the settings.)

| <b>Communication Switch 12</b> |  |                       |
|--------------------------------|--|-----------------------|
| <b>No</b>                      | <b>FUNCTION</b>  | <b>COMMENTS</b>       |
| <b>0 to 7</b>                  | Memory transmission: Interval between dialing attempts to the same destination | 01 - FF (Hex) minutes |

**Communication Switch 13** - Not used (do not change the settings.)



| Communication Switch 14 |   |  |
|-------------------------|---|--|
| No                      | FUNCTION  | COMMENTS   |
| 0                       | Inch-to-mm conversion during transmission<br><b>0:</b> Disabled <b>1:</b> Enabled   | <b>0:</b> In immediate transmission, data scanned in inch format are transmitted without conversion. In memory transmission, data stored in the SAF memory in mm format are transmitted without conversion.<br><b>Note:</b> When storing the scanned data into SAF memory, the fax unit always converts the data into mm format.<br><br><b>1:</b> The machine converts the scanned data or stored data in the SAF memory to the format which was specified in the set-up protocol (DIS/NSF) before transmission. |
| 1 to 5                  | Not used  | Do not change the factory settings.  |
| 6 to 7                  | Available unit of resolution in which fax messages are received<br><b>Bit 7 Bit 6 Unit</b><br>0 0 mm<br>0 1 inch<br>1 0 mm and inch (default)<br>1 1 Not used | For the best performance, do not change the factory settings.<br><br>The setting determined by these bits is informed to the transmitting terminal in the pre-message protocol exchange (in the DIS/NSF frames).   |

|  |
|--|
| <b>Communication Switch 15</b> - Not used (do not change the settings) |
| <b>Communication Switch 16</b> - Not used (do not change the settings) |
| <b>Communication Switch 17</b> - Not used (do not change the settings) |
| <b>Communication Switch 18</b> - Not used (do not change the settings) |
| <b>Communication Switch 19</b> - Not used (do not change the settings) |
| <b>Communication Switch 1A</b> - Not used (do not change the settings) |
| <b>Communication Switch 1B</b> - Not used (do not change the settings) |
| <b>Communication Switch 1C</b> - Not used (do not change the settings) |
| <b>Communication Switch 1D</b> - Not used (do not change the settings) |
| <b>Communication Switch 1E</b> - Not used (do not change the settings) |
| <b>Communication Switch 1F</b> - Not used (do not change the settings) |

## 2.5 G3 SWITCHES

| G3 Switch 00 |   |   |              |                |   |   |          |   |   |               |   |   |              |   |   |          |  |
|--------------|---|---|--------------|----------------|---|---|----------|---|---|---------------|---|---|--------------|---|---|----------|--|
| No           | FUNCTION  | COMMENTS  |              |                |   |   |          |   |   |               |   |   |              |   |   |          |  |
| 0            | Monitor speaker during communication (tx and rx)  | <b>(0, 0):</b> The monitor speaker is disabled all through the communication.   |              |                |   |   |          |   |   |               |   |   |              |   |   |          |  |
| 1            | <table border="0"> <tr> <td><b>Bit 1</b></td> <td><b>Bit 0</b></td> <td><b>Setting</b></td> </tr> <tr> <td>0</td> <td>0</td> <td>Disabled</td> </tr> <tr> <td>0</td> <td>1</td> <td>Up to Phase B</td> </tr> <tr> <td>1</td> <td>0</td> <td>All the time</td> </tr> <tr> <td>1</td> <td>1</td> <td>Not used</td> </tr> </table> | <b>Bit 1</b>  | <b>Bit 0</b> | <b>Setting</b> | 0 | 0 | Disabled | 0 | 1 | Up to Phase B | 1 | 0 | All the time | 1 | 1 | Not used | <b>(0, 1):</b> The monitor speaker is on up to phase B in the T.30 protocol.<br><b>(1, 0):</b> Used for testing. The monitor speaker is on all through the communication. Make sure that you reset these bits after testing. |
| <b>Bit 1</b> | <b>Bit 0</b>  | <b>Setting</b>  |              |                |   |   |          |   |   |               |   |   |              |   |   |          |  |
| 0            | 0   | Disabled  |              |                |   |   |          |   |   |               |   |   |              |   |   |          |  |
| 0            | 1   | Up to Phase B   |              |                |   |   |          |   |   |               |   |   |              |   |   |          |  |
| 1            | 0   | All the time  |              |                |   |   |          |   |   |               |   |   |              |   |   |          |  |
| 1            | 1   | Not used  |              |                |   |   |          |   |   |               |   |   |              |   |   |          |  |
| 2            | Monitor speaker during memory transmission<br><b>0:</b> Disabled <b>1:</b> Enabled  | <b>1:</b> The monitor speaker is enabled during memory transmission.  |              |                |   |   |          |   |   |               |   |   |              |   |   |          |  |
| 3 to 6       | Not used  | Do not change the settings.   |              |                |   |   |          |   |   |               |   |   |              |   |   |          |  |
| 7            | Back to back test<br><b>0:</b> Disabled<br><b>1:</b> Enabled  | Set this bit to 1 when you wish to do a back to back test.<br><b>115 V model:</b> Be sure to connect jumpers JP5 and JP6 on the NCU before doing the test.<br><b>220 V model:</b> Be sure to apply dc voltage between wires L1 and L2 on the NCU. |              |                |   |   |          |   |   |               |   |   |              |   |   |          |  |

Service Tables and Procedures

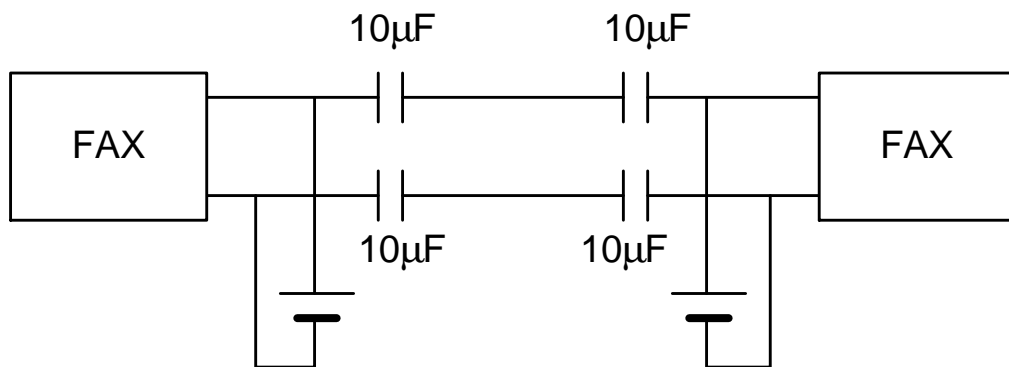

A194M555.img

### Back-to-Back Connection:

The dc power supplies should be adjusted so that the line current to the NCU is about 30mA.



| <b>G3 Switch 01</b>   |   |   |
|-----------------------|---|---|
| <b>No</b>             | <b>FUNCTION</b>   | <b>COMMENTS</b>   |
| <b>0<br/>to<br/>3</b> | Not used  | Do not change the settings.   |
| <b>4</b>              | DIS frame length<br><b>0:</b> 6 bytes <b>1:</b> 4 bytes     | <b>1:</b> The 5th and 6th bytes in the DIS frame will not be transmitted (set to 1 if there are communication problems with PC-based faxes which cannot receive the extended DIS frames). |
| <b>5</b>              | Not used  | Do not change the setting.  |
| <b>6</b>              | CED transmission<br><b>0:</b> Disabled<br><b>1:</b> Enabled | Do not change this setting, unless the communication problem is caused by the CED transmission.   |
| <b>7</b>              | Not used  | Do not change the setting.  |

| <b>G3 Switch 02</b>   |   |  |
|-----------------------|---|--|
| <b>No</b>             | <b>FUNCTION</b>   | <b>COMMENTS</b>  |
| <b>0</b>              | G3 protocol mode used<br><b>0:</b> Standard and non-standard<br><b>1:</b> Standard only                       | Change this bit to 1 only when the other end can only communicate with machines that send T.30-standard frames only.<br><b>1:</b> Disables NSF/NSS signals (these are used in non-standard mode communication)   |
| <b>1<br/>to<br/>4</b> | Not used  | Do not change the settings.  |
| <b>5</b>              | Use of modem rate history for transmission using Quick/Speed Dials<br><b>0:</b> Disabled<br><b>1:</b> Enabled | <b>0:</b> Communications using Quick/Speed Dials always start from the highest modem rate.<br><b>1:</b> The machine refers to the modem rate history for communications with the same machine when determining the most suitable rate for the current communication. |
| <b>6</b>              | AI short protocol (transmission and reception)<br><b>0:</b> Disabled <b>1:</b> Enabled                        | Refer to Appendix B in the Group 3 Facsimile Manual for details about AI Short Protocol.   |
| <b>7</b>              | Short preamble<br><b>0:</b> Disabled <b>1:</b> Enabled  | Refer to Appendix B in the Group 3 Facsimile Manual for details about Short Preamble.  |

| <b>G3 Switch 03</b> |  |   |
|---------------------|--|---|
| <b>No</b>           | <b>FUNCTION</b>  | <b>COMMENTS</b>   |
| <b>0</b>            | DIS detection number<br>(Echo countermeasure)<br><b>0:</b> 1<br><b>1:</b> 2  | <b>0:</b> The machine will hang up if it receives the same DIS frame twice.<br><b>1:</b> Before sending DCS, the machine will wait for the second DIS which is caused by echo on the line.  |
| <b>1</b>            | Not used   | Do not change the setting.  |
| <b>2</b>            |  |   |
| <b>3</b>            | ECM frame size<br><b>0:</b> 256 bytes<br><b>1:</b> 64 bytes  | Keep this bit at "0" in most cases.   |
| <b>4</b>            | CTC transmission conditions<br><b>0:</b> After one PPR signal received<br><b>1:</b> After four PPR signals received (ITU-T standard) | <b>0:</b> When using ECM in non-standard (NSF/NSS) mode, the machine sends a CTC to drop back the modem rate after receiving a PPR, if the following condition is met in communications at 14.4, 12.0, 9.6, and 7.2 kbps.<br><br>$\sqrt{N_{Transmit}} \leq N_{Resend}$<br><br>N <sub>Transmit</sub> - Number of transmitted frames<br>N <sub>Resend</sub> - Number of frames to be retransmitted<br><br><b>1:</b> When using ECM, the machine sends a CTC to drop back the modem rate after receiving four PPRs.<br><br>PPR, CTC: These are ECM protocol signals. |
| <b>5</b>            | Modem rate used for the next page after receiving a negative code (RTN or PIN)<br><b>0:</b> No change <b>1:</b> Fallback             | <b>1:</b> The machine's tx modem rate will fall back before sending the next page if a negative code is received. This bit is ignored if ECM is being used.   |
| <b>6</b>            | Not used   | Do not change the setting.  |
| <b>7</b>            |  |   |

| <b>G3 Switch 04</b> |                                    |  |
|---------------------|------------------------------------|--|
|                     | <b>FUNCTION</b>                    | <b>COMMENTS</b>  |
| <b>0 to 3</b>       | Training error detection threshold | 0 - F (Hex); 0 - 15 bits<br>If the number of error bits in the received TCF is below this threshold, the machine informs the sender that training has succeeded. |
| <b>4 to 7</b>       | Not used                           | Do not change the settings.  |

| <b>G3 Switch 05</b> |  |  |
|---------------------|--|--|
|                     | <b>FUNCTION</b>  | <b>COMMENTS</b>  |
| <b>0 to 3</b>       | Initial Tx modem rate<br><b>Bit 3 2 1 0 Setting (bps)</b><br>0 0 0 1 2.4 k<br>0 0 1 0 4.8 k<br>0 0 1 1 7.2 k<br>0 1 0 0 9.6 k<br>0 1 0 1 12 k<br>0 1 1 0 14.4 k<br>Other settings - Not used | These bits set the initial starting modem rate for transmission.<br><br>Use the dedicated transmission parameters if you need to change this for specific receivers. |
| <b>4 to 5</b>       | Initial modem type for 9.6 k or 7.2 kbps.<br><b>Bit 5 Bit 4 Setting</b><br>0 0 V.29<br>0 1 V.17<br>1 0 Not used<br>1 1 Not used  | These bits set the initial modem type for 9.6 and 7.2 kbps, if the initial modem rate is set at these speeds.  |
| <b>6 to 7</b>       | Not used   | Do not change the settings.  |

| <b>G3 Switch 06</b> |  |  |
|---------------------|--|--|
|                     | <b>FUNCTION</b>  | <b>COMMENTS</b>  |
| <b>0 to 3</b>       | Initial Rx modem rate<br><b>Bit 3 2 1 0 Setting (bps)</b><br>0 0 0 1 2.4 k<br>0 0 1 0 4.8 k<br>0 0 1 1 7.2 k<br>0 1 0 0 9.6 k<br>0 1 0 1 12 k<br>0 1 1 0 14.4 k<br>Other settings - Not used       | The setting of these bits is used to inform the transmitting terminal of the available modem rate for the machine in receive mode. Use a lower setting if high speeds pose problems during reception.<br><br>The machine automatically determines whether to use TCM or not. |
| <b>4 to 7</b>       | Modem types available for reception<br><b>Bit 7 6 5 4 Setting</b><br>0 0 0 1 V.27ter<br>0 0 1 0 V.27ter, V.29<br>0 0 1 1 V.27ter, V.29<br>0 1 0 0 V.27ter, V.29, V.17<br>Other settings - Not used | The setting of these bits is used to inform the transmitting terminal of the available modem type for the machine in receive mode.   |

| <b>G3 Switch 07</b> |                                |              |                |   |
|---------------------|--------------------------------|--------------|----------------|---|
|                     | <b>FUNCTION</b>                |              |                | <b>COMMENTS</b>   |
| <b>0</b>            | PSTN cable equalizer (tx mode) |              |                | Use a higher setting if there is signal loss at higher frequencies because of the length of wire between the modem and the telephone exchange.<br>Use the dedicated transmission parameters for specific receivers.<br><br>Also, try using the cable equalizer if one or more of the following symptoms occurs. <ul style="list-style-type: none"> <li>• Communication error</li> <li>• Modem rate fallback occurs frequently.</li> </ul> |
| <b>1</b>            | <b>Bit 1</b>                   | <b>Bit 0</b> | <b>Setting</b> |   |
|                     | 0                              | 0            | None           |   |
|                     | 0                              | 1            | Low            |   |
|                     | 1                              | 0            | Medium         |   |
|                     | 1                              | 1            | High           |   |
| <b>2</b>            | PSTN cable equalizer (rx mode) |              |                | Use a higher setting if there is signal loss at higher frequencies because of the length of wire between the modem and the telephone exchange.<br><br>Also, try using the cable equalizer if one or more of the following symptoms occurs. <ul style="list-style-type: none"> <li>• Communication error with error codes such as 0-20, 0-23, etc.</li> <li>• Modem rate fallback occurs frequently.</li> </ul>                            |
| <b>3</b>            | <b>Bit 3</b>                   | <b>Bit 2</b> | <b>Setting</b> |   |
|                     | 0                              | 0            | None           |   |
|                     | 0                              | 1            | Low            |   |
|                     | 1                              | 0            | Medium         |   |
|                     | 1                              | 1            | High           |   |
| <b>4 to 7</b>       | Not used                       |              |                | Do not change the settings.   |

**G3 Switch 08** - Not used (do not change the settings)

| <b>G3 Switch 09</b> |                                |              |                |   |
|---------------------|--------------------------------|--------------|----------------|---|
|                     | <b>FUNCTION</b>                |              |                | <b>COMMENTS</b>   |
| <b>0</b>            | ISDN cable equalizer (tx mode) |              |                | Use a higher setting if there is signal loss at higher frequencies because of the length of wire between the modem and the telephone exchange.<br>Use the dedicated transmission parameters for specific receivers.<br><br>Also, try using the cable equalizer if one or more of the following symptoms occurs. <ul style="list-style-type: none"> <li>• Communication error</li> <li>• Modem rate fallback occurs frequently.</li> </ul> |
| <b>1</b>            | <b>Bit 1</b>                   | <b>Bit 0</b> | <b>Setting</b> |   |
|                     | 0                              | 0            | None           |   |
|                     | 0                              | 1            | Low            |   |
|                     | 1                              | 0            | Medium         |   |
|                     | 1                              | 1            | High           |   |
| <b>2</b>            | ISDN cable equalizer (rx mode) |              |                | Use a higher setting if there is signal loss at higher frequencies because of the length of wire between the modem and the telephone exchange.<br><br>Also, try using the cable equalizer if one or more of the following symptoms occurs. <ul style="list-style-type: none"> <li>• Communication error with error codes such as 0-20, 0-23, etc.</li> <li>• Modem rate fallback occurs frequently.</li> </ul>                            |
| <b>3</b>            | <b>Bit 3</b>                   | <b>Bit 2</b> | <b>Setting</b> |   |
|                     | 0                              | 0            | None           |   |
|                     | 0                              | 1            | Low            |   |
|                     | 1                              | 0            | Medium         |   |
|                     | 1                              | 1            | High           |   |

Service Tables and Procedures

| <b>G3 Switch 09</b> |                 |                             |
|---------------------|-----------------|-----------------------------|
|                     | <b>FUNCTION</b> | <b>COMMENTS</b>             |
| <b>4 to 7</b>       | Not used        | Do not change the settings. |

| <b>G3 Switch 0A</b> |   |   |            |       |            |   |   |     |   |   |     |   |   |     |   |   |          |
|---------------------|---|---|------------|-------|------------|---|---|-----|---|---|-----|---|---|-----|---|---|----------|
|                     | <b>FUNCTION</b>   | <b>COMMENTS</b>   |            |       |            |   |   |     |   |   |     |   |   |     |   |   |          |
| <b>0</b>            | Maximum allowable carrier drop during image data reception  | These bits set the acceptable modem carrier drop time. Try using a longer setting if error code 0-22 is frequent.   |            |       |            |   |   |     |   |   |     |   |   |     |   |   |          |
| <b>1</b>            | <table border="1"> <thead> <tr> <th>Bit 1</th> <th>Bit 0</th> <th>Value (ms)</th> </tr> </thead> <tbody> <tr> <td>0</td> <td>0</td> <td>200</td> </tr> <tr> <td>0</td> <td>1</td> <td>400</td> </tr> <tr> <td>1</td> <td>0</td> <td>800</td> </tr> <tr> <td>1</td> <td>1</td> <td>Not used</td> </tr> </tbody> </table> |   | Bit 1      | Bit 0 | Value (ms) | 0 | 0 | 200 | 0 | 1 | 400 | 1 | 0 | 800 | 1 | 1 | Not used |
| Bit 1               | Bit 0   |   | Value (ms) |       |            |   |   |     |   |   |     |   |   |     |   |   |          |
| 0                   | 0   |   | 200        |       |            |   |   |     |   |   |     |   |   |     |   |   |          |
| 0                   | 1   |   | 400        |       |            |   |   |     |   |   |     |   |   |     |   |   |          |
| 1                   | 0   | 800   |            |       |            |   |   |     |   |   |     |   |   |     |   |   |          |
| 1                   | 1   | Not used  |            |       |            |   |   |     |   |   |     |   |   |     |   |   |          |
| <b>2</b>            | Not used  | Do not change the settings.   |            |       |            |   |   |     |   |   |     |   |   |     |   |   |          |
| <b>3</b>            |   |   |            |       |            |   |   |     |   |   |     |   |   |     |   |   |          |
| <b>4</b>            | Maximum allowable frame interval during image data reception.<br><b>0: 5 s    1: 13 s</b>   | This bit set the maximum intervals between each EOL signal (end-of-line) or intervals between each ECM frame from the other end. Try using a longer setting if error code 0-21 is frequent.   |            |       |            |   |   |     |   |   |     |   |   |     |   |   |          |
| <b>5</b>            | Not used  | Do not change the settings.   |            |       |            |   |   |     |   |   |     |   |   |     |   |   |          |
| <b>6</b>            | Reconstruction time for the first line in receive mode<br><b>0: 6 s    1: 12 s</b>  | When the sending terminal is controlled by a computer, there may be a delay in receiving page data after the local machine accepts set-up data and sends CFR. This is outside the T.30 recommendation. But, if this delay occurs, set this bit to 1 to give the sending machine more time to send data. Refer to error code 0-20.<br><br>ITU-T T.30 recommendation: The first line should come within 5 s of CFR. |            |       |            |   |   |     |   |   |     |   |   |     |   |   |          |
| <b>7</b>            | Not used  | Do not change the settings.   |            |       |            |   |   |     |   |   |     |   |   |     |   |   |          |

| <b>G3 Switch 0B</b> |   |   |
|---------------------|---|---|
|                     | <b>FUNCTION</b>   | <b>COMMENTS</b>   |
| <b>0</b>            | Protocol requirements: Europe<br><b>0: Disabled 1: Enabled</b>  | The machine does not automatically reset these bits for each country after a country code (System Switch 0F) is programmed.<br>Change the required bits manually at installation. |
| <b>1</b>            | Protocol requirements: Spain<br><b>0: Disabled 1: Enabled</b>   |   |
| <b>2</b>            | Protocol requirements: Germany<br><b>0: Disabled 1: Enabled</b> |   |
| <b>3</b>            | Protocol requirements: France<br><b>0: Disabled 1: Enabled</b>  |   |
| <b>4</b>            | PTT requirements: Germany<br><b>0: Disabled 1: Enabled</b>      |   |
| <b>5</b>            | PTT requirements: France<br><b>0: Disabled 1: Enabled</b>       |   |
| <b>6</b>            | Not used  | Do not change the settings.   |
| <b>7</b>            |   |   |

| <b>G3 Switch 0C</b> |  |   |
|---------------------|--|---|
|                     | <b>FUNCTION</b>                                    | <b>COMMENTS</b>                                   |
| <b>0</b>            | Pulse dialing method<br><b>Bit 1 Bit 0 Setting</b> | P = Number of pulses sent out, N = Number dialed. |
| <b>1</b>            | 0 0 Normal (P=N)                                   |   |
|                     | 0 1 Oslo (P=10 - N)                                |   |
|                     | 1 0 Sweden (N+1)                                   |   |
|                     | 1 1 Not used                                       |   |
| <b>2 to 7</b>       | Not used   | Do not change the settings.                       |

**Service Tables and Procedures**

|   |
|---|
| <b>G3 Switch 0D</b> - Not used (do not change the settings) |
| <b>G3 Switch 0E</b> - Not used (do not change the settings) |
| <b>G3 Switch 0F</b> - Not used (do not change the settings) |



### 3. NCU PARAMETERS

The following tables give the RAM addresses and units of calculation of the parameters that the machine uses for ringing signal detection and automatic dialing. The factory settings for each country are also given. Most of these must be changed by RAM read/write (Function 06-1), but some can be changed using NCU Parameter programming (Function 06-2); if Function 06-2 can be used, this will be indicated in the Remarks column. The RAM is programmed in hex code unless (BCD) is included in the Unit column.



| Address      | Function                        | Unit  | Remarks   |         |         |     |        |    |    |         |    |    |    |    |    |       |    |    |         |    |    |         |    |    |         |    |    |         |    |    |         |    |    |        |    |    |        |    |    |             |    |    |          |    |    |         |    |    |       |    |    |        |    |    |     |    |    |      |    |    |           |    |    |              |    |    |           |    |    |             |    |    |           |    |    |          |    |    |       |    |    |        |    |    |        |    |    |        |    |    |
|--------------|---------------------------------|-------|---|---------|---------|-----|--------|----|----|---------|----|----|----|----|----|-------|----|----|---------|----|----|---------|----|----|---------|----|----|---------|----|----|---------|----|----|--------|----|----|--------|----|----|-------------|----|----|----------|----|----|---------|----|----|-------|----|----|--------|----|----|-----|----|----|------|----|----|-----------|----|----|--------------|----|----|-----------|----|----|-------------|----|----|-----------|----|----|----------|----|----|-------|----|----|--------|----|----|--------|----|----|--------|----|----|
| 480400       | Country code for NCU parameters |       | Use the Hex value to program the country code directly into this address, or use the decimal value to program it using Function 06-2 (parameter 00).<br><br><table border="1"> <thead> <tr> <th>Country</th> <th>Decimal</th> <th>Hex</th> </tr> </thead> <tbody> <tr><td>France</td><td>00</td><td>00</td></tr> <tr><td>Germany</td><td>01</td><td>01</td></tr> <tr><td>UK</td><td>02</td><td>02</td></tr> <tr><td>Italy</td><td>03</td><td>03</td></tr> <tr><td>Austria</td><td>04</td><td>04</td></tr> <tr><td>Belgium</td><td>05</td><td>05</td></tr> <tr><td>Denmark</td><td>06</td><td>06</td></tr> <tr><td>Finland</td><td>07</td><td>07</td></tr> <tr><td>Ireland</td><td>08</td><td>08</td></tr> <tr><td>Norway</td><td>09</td><td>09</td></tr> <tr><td>Sweden</td><td>10</td><td>0A</td></tr> <tr><td>Switzerland</td><td>11</td><td>0B</td></tr> <tr><td>Portugal</td><td>12</td><td>0C</td></tr> <tr><td>Holland</td><td>13</td><td>0D</td></tr> <tr><td>Spain</td><td>14</td><td>0E</td></tr> <tr><td>Israel</td><td>15</td><td>0F</td></tr> <tr><td>USA</td><td>17</td><td>11</td></tr> <tr><td>Asia</td><td>18</td><td>12</td></tr> <tr><td>Hong Kong</td><td>20</td><td>14</td></tr> <tr><td>South Africa</td><td>21</td><td>15</td></tr> <tr><td>Australia</td><td>22</td><td>16</td></tr> <tr><td>New Zealand</td><td>23</td><td>17</td></tr> <tr><td>Singapore</td><td>24</td><td>18</td></tr> <tr><td>Malaysia</td><td>25</td><td>19</td></tr> <tr><td>China</td><td>26</td><td>1A</td></tr> <tr><td>Taiwan</td><td>27</td><td>1B</td></tr> <tr><td>Turkey</td><td>32</td><td>20</td></tr> <tr><td>Greece</td><td>33</td><td>21</td></tr> </tbody> </table> | Country | Decimal | Hex | France | 00 | 00 | Germany | 01 | 01 | UK | 02 | 02 | Italy | 03 | 03 | Austria | 04 | 04 | Belgium | 05 | 05 | Denmark | 06 | 06 | Finland | 07 | 07 | Ireland | 08 | 08 | Norway | 09 | 09 | Sweden | 10 | 0A | Switzerland | 11 | 0B | Portugal | 12 | 0C | Holland | 13 | 0D | Spain | 14 | 0E | Israel | 15 | 0F | USA | 17 | 11 | Asia | 18 | 12 | Hong Kong | 20 | 14 | South Africa | 21 | 15 | Australia | 22 | 16 | New Zealand | 23 | 17 | Singapore | 24 | 18 | Malaysia | 25 | 19 | China | 26 | 1A | Taiwan | 27 | 1B | Turkey | 32 | 20 | Greece | 33 | 21 |
| Country      | Decimal                         | Hex   |   |         |         |     |        |    |    |         |    |    |    |    |    |       |    |    |         |    |    |         |    |    |         |    |    |         |    |    |         |    |    |        |    |    |        |    |    |             |    |    |          |    |    |         |    |    |       |    |    |        |    |    |     |    |    |      |    |    |           |    |    |              |    |    |           |    |    |             |    |    |           |    |    |          |    |    |       |    |    |        |    |    |        |    |    |        |    |    |
| France       | 00                              | 00    |   |         |         |     |        |    |    |         |    |    |    |    |    |       |    |    |         |    |    |         |    |    |         |    |    |         |    |    |         |    |    |        |    |    |        |    |    |             |    |    |          |    |    |         |    |    |       |    |    |        |    |    |     |    |    |      |    |    |           |    |    |              |    |    |           |    |    |             |    |    |           |    |    |          |    |    |       |    |    |        |    |    |        |    |    |        |    |    |
| Germany      | 01                              | 01    |   |         |         |     |        |    |    |         |    |    |    |    |    |       |    |    |         |    |    |         |    |    |         |    |    |         |    |    |         |    |    |        |    |    |        |    |    |             |    |    |          |    |    |         |    |    |       |    |    |        |    |    |     |    |    |      |    |    |           |    |    |              |    |    |           |    |    |             |    |    |           |    |    |          |    |    |       |    |    |        |    |    |        |    |    |        |    |    |
| UK           | 02                              | 02    |   |         |         |     |        |    |    |         |    |    |    |    |    |       |    |    |         |    |    |         |    |    |         |    |    |         |    |    |         |    |    |        |    |    |        |    |    |             |    |    |          |    |    |         |    |    |       |    |    |        |    |    |     |    |    |      |    |    |           |    |    |              |    |    |           |    |    |             |    |    |           |    |    |          |    |    |       |    |    |        |    |    |        |    |    |        |    |    |
| Italy        | 03                              | 03    |   |         |         |     |        |    |    |         |    |    |    |    |    |       |    |    |         |    |    |         |    |    |         |    |    |         |    |    |         |    |    |        |    |    |        |    |    |             |    |    |          |    |    |         |    |    |       |    |    |        |    |    |     |    |    |      |    |    |           |    |    |              |    |    |           |    |    |             |    |    |           |    |    |          |    |    |       |    |    |        |    |    |        |    |    |        |    |    |
| Austria      | 04                              | 04    |   |         |         |     |        |    |    |         |    |    |    |    |    |       |    |    |         |    |    |         |    |    |         |    |    |         |    |    |         |    |    |        |    |    |        |    |    |             |    |    |          |    |    |         |    |    |       |    |    |        |    |    |     |    |    |      |    |    |           |    |    |              |    |    |           |    |    |             |    |    |           |    |    |          |    |    |       |    |    |        |    |    |        |    |    |        |    |    |
| Belgium      | 05                              | 05    |   |         |         |     |        |    |    |         |    |    |    |    |    |       |    |    |         |    |    |         |    |    |         |    |    |         |    |    |         |    |    |        |    |    |        |    |    |             |    |    |          |    |    |         |    |    |       |    |    |        |    |    |     |    |    |      |    |    |           |    |    |              |    |    |           |    |    |             |    |    |           |    |    |          |    |    |       |    |    |        |    |    |        |    |    |        |    |    |
| Denmark      | 06                              | 06    |   |         |         |     |        |    |    |         |    |    |    |    |    |       |    |    |         |    |    |         |    |    |         |    |    |         |    |    |         |    |    |        |    |    |        |    |    |             |    |    |          |    |    |         |    |    |       |    |    |        |    |    |     |    |    |      |    |    |           |    |    |              |    |    |           |    |    |             |    |    |           |    |    |          |    |    |       |    |    |        |    |    |        |    |    |        |    |    |
| Finland      | 07                              | 07    |   |         |         |     |        |    |    |         |    |    |    |    |    |       |    |    |         |    |    |         |    |    |         |    |    |         |    |    |         |    |    |        |    |    |        |    |    |             |    |    |          |    |    |         |    |    |       |    |    |        |    |    |     |    |    |      |    |    |           |    |    |              |    |    |           |    |    |             |    |    |           |    |    |          |    |    |       |    |    |        |    |    |        |    |    |        |    |    |
| Ireland      | 08                              | 08    |   |         |         |     |        |    |    |         |    |    |    |    |    |       |    |    |         |    |    |         |    |    |         |    |    |         |    |    |         |    |    |        |    |    |        |    |    |             |    |    |          |    |    |         |    |    |       |    |    |        |    |    |     |    |    |      |    |    |           |    |    |              |    |    |           |    |    |             |    |    |           |    |    |          |    |    |       |    |    |        |    |    |        |    |    |        |    |    |
| Norway       | 09                              | 09    |   |         |         |     |        |    |    |         |    |    |    |    |    |       |    |    |         |    |    |         |    |    |         |    |    |         |    |    |         |    |    |        |    |    |        |    |    |             |    |    |          |    |    |         |    |    |       |    |    |        |    |    |     |    |    |      |    |    |           |    |    |              |    |    |           |    |    |             |    |    |           |    |    |          |    |    |       |    |    |        |    |    |        |    |    |        |    |    |
| Sweden       | 10                              | 0A    |   |         |         |     |        |    |    |         |    |    |    |    |    |       |    |    |         |    |    |         |    |    |         |    |    |         |    |    |         |    |    |        |    |    |        |    |    |             |    |    |          |    |    |         |    |    |       |    |    |        |    |    |     |    |    |      |    |    |           |    |    |              |    |    |           |    |    |             |    |    |           |    |    |          |    |    |       |    |    |        |    |    |        |    |    |        |    |    |
| Switzerland  | 11                              | 0B    |   |         |         |     |        |    |    |         |    |    |    |    |    |       |    |    |         |    |    |         |    |    |         |    |    |         |    |    |         |    |    |        |    |    |        |    |    |             |    |    |          |    |    |         |    |    |       |    |    |        |    |    |     |    |    |      |    |    |           |    |    |              |    |    |           |    |    |             |    |    |           |    |    |          |    |    |       |    |    |        |    |    |        |    |    |        |    |    |
| Portugal     | 12                              | 0C    |   |         |         |     |        |    |    |         |    |    |    |    |    |       |    |    |         |    |    |         |    |    |         |    |    |         |    |    |         |    |    |        |    |    |        |    |    |             |    |    |          |    |    |         |    |    |       |    |    |        |    |    |     |    |    |      |    |    |           |    |    |              |    |    |           |    |    |             |    |    |           |    |    |          |    |    |       |    |    |        |    |    |        |    |    |        |    |    |
| Holland      | 13                              | 0D    |   |         |         |     |        |    |    |         |    |    |    |    |    |       |    |    |         |    |    |         |    |    |         |    |    |         |    |    |         |    |    |        |    |    |        |    |    |             |    |    |          |    |    |         |    |    |       |    |    |        |    |    |     |    |    |      |    |    |           |    |    |              |    |    |           |    |    |             |    |    |           |    |    |          |    |    |       |    |    |        |    |    |        |    |    |        |    |    |
| Spain        | 14                              | 0E    |   |         |         |     |        |    |    |         |    |    |    |    |    |       |    |    |         |    |    |         |    |    |         |    |    |         |    |    |         |    |    |        |    |    |        |    |    |             |    |    |          |    |    |         |    |    |       |    |    |        |    |    |     |    |    |      |    |    |           |    |    |              |    |    |           |    |    |             |    |    |           |    |    |          |    |    |       |    |    |        |    |    |        |    |    |        |    |    |
| Israel       | 15                              | 0F    |   |         |         |     |        |    |    |         |    |    |    |    |    |       |    |    |         |    |    |         |    |    |         |    |    |         |    |    |         |    |    |        |    |    |        |    |    |             |    |    |          |    |    |         |    |    |       |    |    |        |    |    |     |    |    |      |    |    |           |    |    |              |    |    |           |    |    |             |    |    |           |    |    |          |    |    |       |    |    |        |    |    |        |    |    |        |    |    |
| USA          | 17                              | 11    |   |         |         |     |        |    |    |         |    |    |    |    |    |       |    |    |         |    |    |         |    |    |         |    |    |         |    |    |         |    |    |        |    |    |        |    |    |             |    |    |          |    |    |         |    |    |       |    |    |        |    |    |     |    |    |      |    |    |           |    |    |              |    |    |           |    |    |             |    |    |           |    |    |          |    |    |       |    |    |        |    |    |        |    |    |        |    |    |
| Asia         | 18                              | 12    |   |         |         |     |        |    |    |         |    |    |    |    |    |       |    |    |         |    |    |         |    |    |         |    |    |         |    |    |         |    |    |        |    |    |        |    |    |             |    |    |          |    |    |         |    |    |       |    |    |        |    |    |     |    |    |      |    |    |           |    |    |              |    |    |           |    |    |             |    |    |           |    |    |          |    |    |       |    |    |        |    |    |        |    |    |        |    |    |
| Hong Kong    | 20                              | 14    |   |         |         |     |        |    |    |         |    |    |    |    |    |       |    |    |         |    |    |         |    |    |         |    |    |         |    |    |         |    |    |        |    |    |        |    |    |             |    |    |          |    |    |         |    |    |       |    |    |        |    |    |     |    |    |      |    |    |           |    |    |              |    |    |           |    |    |             |    |    |           |    |    |          |    |    |       |    |    |        |    |    |        |    |    |        |    |    |
| South Africa | 21                              | 15    |   |         |         |     |        |    |    |         |    |    |    |    |    |       |    |    |         |    |    |         |    |    |         |    |    |         |    |    |         |    |    |        |    |    |        |    |    |             |    |    |          |    |    |         |    |    |       |    |    |        |    |    |     |    |    |      |    |    |           |    |    |              |    |    |           |    |    |             |    |    |           |    |    |          |    |    |       |    |    |        |    |    |        |    |    |        |    |    |
| Australia    | 22                              | 16    |   |         |         |     |        |    |    |         |    |    |    |    |    |       |    |    |         |    |    |         |    |    |         |    |    |         |    |    |         |    |    |        |    |    |        |    |    |             |    |    |          |    |    |         |    |    |       |    |    |        |    |    |     |    |    |      |    |    |           |    |    |              |    |    |           |    |    |             |    |    |           |    |    |          |    |    |       |    |    |        |    |    |        |    |    |        |    |    |
| New Zealand  | 23                              | 17    |   |         |         |     |        |    |    |         |    |    |    |    |    |       |    |    |         |    |    |         |    |    |         |    |    |         |    |    |         |    |    |        |    |    |        |    |    |             |    |    |          |    |    |         |    |    |       |    |    |        |    |    |     |    |    |      |    |    |           |    |    |              |    |    |           |    |    |             |    |    |           |    |    |          |    |    |       |    |    |        |    |    |        |    |    |        |    |    |
| Singapore    | 24                              | 18    |   |         |         |     |        |    |    |         |    |    |    |    |    |       |    |    |         |    |    |         |    |    |         |    |    |         |    |    |         |    |    |        |    |    |        |    |    |             |    |    |          |    |    |         |    |    |       |    |    |        |    |    |     |    |    |      |    |    |           |    |    |              |    |    |           |    |    |             |    |    |           |    |    |          |    |    |       |    |    |        |    |    |        |    |    |        |    |    |
| Malaysia     | 25                              | 19    |   |         |         |     |        |    |    |         |    |    |    |    |    |       |    |    |         |    |    |         |    |    |         |    |    |         |    |    |         |    |    |        |    |    |        |    |    |             |    |    |          |    |    |         |    |    |       |    |    |        |    |    |     |    |    |      |    |    |           |    |    |              |    |    |           |    |    |             |    |    |           |    |    |          |    |    |       |    |    |        |    |    |        |    |    |        |    |    |
| China        | 26                              | 1A    |   |         |         |     |        |    |    |         |    |    |    |    |    |       |    |    |         |    |    |         |    |    |         |    |    |         |    |    |         |    |    |        |    |    |        |    |    |             |    |    |          |    |    |         |    |    |       |    |    |        |    |    |     |    |    |      |    |    |           |    |    |              |    |    |           |    |    |             |    |    |           |    |    |          |    |    |       |    |    |        |    |    |        |    |    |        |    |    |
| Taiwan       | 27                              | 1B    |   |         |         |     |        |    |    |         |    |    |    |    |    |       |    |    |         |    |    |         |    |    |         |    |    |         |    |    |         |    |    |        |    |    |        |    |    |             |    |    |          |    |    |         |    |    |       |    |    |        |    |    |     |    |    |      |    |    |           |    |    |              |    |    |           |    |    |             |    |    |           |    |    |          |    |    |       |    |    |        |    |    |        |    |    |        |    |    |
| Turkey       | 32                              | 20    |   |         |         |     |        |    |    |         |    |    |    |    |    |       |    |    |         |    |    |         |    |    |         |    |    |         |    |    |         |    |    |        |    |    |        |    |    |             |    |    |          |    |    |         |    |    |       |    |    |        |    |    |     |    |    |      |    |    |           |    |    |              |    |    |           |    |    |             |    |    |           |    |    |          |    |    |       |    |    |        |    |    |        |    |    |        |    |    |
| Greece       | 33                              | 21    |   |         |         |     |        |    |    |         |    |    |    |    |    |       |    |    |         |    |    |         |    |    |         |    |    |         |    |    |         |    |    |        |    |    |        |    |    |             |    |    |          |    |    |         |    |    |       |    |    |        |    |    |     |    |    |      |    |    |           |    |    |              |    |    |           |    |    |             |    |    |           |    |    |          |    |    |       |    |    |        |    |    |        |    |    |        |    |    |
| 480401       | Line current detection time     | 20 ms | Line current is not detected if 480401 contains FF.   |         |         |     |        |    |    |         |    |    |    |    |    |       |    |    |         |    |    |         |    |    |         |    |    |         |    |    |         |    |    |        |    |    |        |    |    |             |    |    |          |    |    |         |    |    |       |    |    |        |    |    |     |    |    |      |    |    |           |    |    |              |    |    |           |    |    |             |    |    |           |    |    |          |    |    |       |    |    |        |    |    |        |    |    |        |    |    |
| 480402       | Line current wait time          |       |   |         |         |     |        |    |    |         |    |    |    |    |    |       |    |    |         |    |    |         |    |    |         |    |    |         |    |    |         |    |    |        |    |    |        |    |    |             |    |    |          |    |    |         |    |    |       |    |    |        |    |    |     |    |    |      |    |    |           |    |    |              |    |    |           |    |    |             |    |    |           |    |    |          |    |    |       |    |    |        |    |    |        |    |    |        |    |    |
| 480403       | Line current drop detect time   |       |   |         |         |     |        |    |    |         |    |    |    |    |    |       |    |    |         |    |    |         |    |    |         |    |    |         |    |    |         |    |    |        |    |    |        |    |    |             |    |    |          |    |    |         |    |    |       |    |    |        |    |    |     |    |    |      |    |    |           |    |    |              |    |    |           |    |    |             |    |    |           |    |    |          |    |    |       |    |    |        |    |    |        |    |    |        |    |    |

| Address | Function  | Unit     | Remarks  |
|---------|---|----------|--|
| 480404  | PSTN dial tone frequency upper limit (high byte)                          | Hz (BCD) | If both addresses contain FF(F), tone detection is disabled.   |
| 480405  | PSTN dial tone frequency upper limit (low byte)                           |          |  |
| 480406  | PSTN dial tone frequency lower limit (high byte)                          | Hz (BCD) | If both addresses contain FF(F), tone detection is disabled.   |
| 480407  | PSTN dial tone frequency lower limit (low byte)                           |          |  |
| 480408  | PSTN dial tone detection time   | 20 ms    | If 480408 contains FF, the machine pauses for the pause time (address 48040D / 48040E).<br><br>See Note 2 (Italy). |
| 480409  | PSTN dial tone reset time (LOW)   |          |  |
| 48040A  | PSTN dial tone reset time (HIGH)  |          |  |
| 48040B  | PSTN dial tone continuous tone time                                       |          |  |
| 48040C  | PSTN dial tone permissible drop time                                      |          |  |
| 48040D  | PSTN wait interval (LOW)  |          |  |
| 48040E  | PSTN wait interval (HIGH)   |          |  |
| 48040F  | PSTN ringback tone detection time   | 20 ms    | Detection is disabled if this contains FF.   |
| 480410  | PSTN ringback tone off detection time                                     | 20 ms    |  |
| 480411  | PSTN detection time for silent period after ringback tone detected (LOW)  | 20 ms    |  |
| 480412  | PSTN detection time for silent period after ringback tone detected (HIGH) | 20 ms    |  |
| 480413  | PSTN busy tone frequency upper limit (high byte)                          | Hz (BCD) | If both addresses contain FF(F), tone detection is disabled.   |
| 480414  | PSTN busy tone frequency upper limit (low byte)                           |          |  |
| 480415  | PSTN busy tone frequency lower limit (high byte)                          | Hz (BCD) | If both addresses contain FF(F), tone detection is disabled.   |
| 480416  | PSTN busy tone frequency lower limit (low byte)                           |          |  |
| 480417  | PABX dial tone frequency upper limit (high byte)                          | Hz (BCD) | If both addresses contain FF(F), tone detection is disabled.   |
| 480418  | PABX dial tone frequency upper limit (low byte)                           |          |  |
| 480419  | PABX dial tone frequency lower limit (high byte)                          | Hz (BCD) | If both addresses contain FF(F), tone detection is disabled.   |
| 48041A  | PABX dial tone frequency lower limit (low byte)                           |          |  |



| Address | Function  | Unit     | Remarks   |     |   |   |  |  |   |   |     |  |   |   |     |  |   |   |     |  |   |   |       |
|---------|---|----------|---|-----|---|---|--|--|---|---|-----|--|---|---|-----|--|---|---|-----|--|---|---|-------|
| 48041B  | PABX dial tone detection time   | 20 ms    | If 48041B contains FF, the machine pauses for the pause time (480420 / 480421). |     |   |   |  |  |   |   |     |  |   |   |     |  |   |   |     |  |   |   |       |
| 48041C  | PABX dial tone reset time (LOW)   |          |   |     |   |   |  |  |   |   |     |  |   |   |     |  |   |   |     |  |   |   |       |
| 48041D  | PABX dial tone reset time (HIGH)  |          |   |     |   |   |  |  |   |   |     |  |   |   |     |  |   |   |     |  |   |   |       |
| 48041E  | PABX dial tone continuous tone time   |          |   |     |   |   |  |  |   |   |     |  |   |   |     |  |   |   |     |  |   |   |       |
| 48041F  | PABX dial tone permissible drop time  |          |   |     |   |   |  |  |   |   |     |  |   |   |     |  |   |   |     |  |   |   |       |
| 480420  | PABX wait interval (HIGH)   |          |   |     |   |   |  |  |   |   |     |  |   |   |     |  |   |   |     |  |   |   |       |
| 480421  | PABX wait interval (LOW)  |          |   |     |   |   |  |  |   |   |     |  |   |   |     |  |   |   |     |  |   |   |       |
| 480422  | PABX ringback tone detection time   | 20 ms    | Detection is disabled if this contains FF.                                      |     |   |   |  |  |   |   |     |  |   |   |     |  |   |   |     |  |   |   |       |
| 480423  | PABX ringback tone off detection time   | 20 ms    |   |     |   |   |  |  |   |   |     |  |   |   |     |  |   |   |     |  |   |   |       |
| 480424  | PABX detection time for silent period after ringback tone detected (LOW)  | 20 ms    |   |     |   |   |  |  |   |   |     |  |   |   |     |  |   |   |     |  |   |   |       |
| 480425  | PABX detection time for silent period after ringback tone detected (HIGH)   | 20 ms    |   |     |   |   |  |  |   |   |     |  |   |   |     |  |   |   |     |  |   |   |       |
| 480426  | PABX busy tone frequency upper limit (high byte)  | Hz (BCD) | If both addresses contain FF(F), tone detection is disabled.                    |     |   |   |  |  |   |   |     |  |   |   |     |  |   |   |     |  |   |   |       |
| 480427  | PABX busy tone frequency upper limit (low byte)   |          |   |     |   |   |  |  |   |   |     |  |   |   |     |  |   |   |     |  |   |   |       |
| 480428  | PABX busy tone frequency lower limit (high byte)  | Hz (BCD) | If both addresses contain FF(F), tone detection is disabled.                    |     |   |   |  |  |   |   |     |  |   |   |     |  |   |   |     |  |   |   |       |
| 480429  | PABX busy tone frequency lower limit (low byte)   |          |   |     |   |   |  |  |   |   |     |  |   |   |     |  |   |   |     |  |   |   |       |
| 48042A  | Busy tone ON time: range 1  | 20 ms    |   |     |   |   |  |  |   |   |     |  |   |   |     |  |   |   |     |  |   |   |       |
| 48042B  | Busy tone OFF time: range 1   |          |   |     |   |   |  |  |   |   |     |  |   |   |     |  |   |   |     |  |   |   |       |
| 48042C  | Busy tone ON time: range 2  |          |   |     |   |   |  |  |   |   |     |  |   |   |     |  |   |   |     |  |   |   |       |
| 48042D  | Busy tone OFF time: range 2   |          |   |     |   |   |  |  |   |   |     |  |   |   |     |  |   |   |     |  |   |   |       |
| 48042E  | Busy tone ON time: range 3  |          |   |     |   |   |  |  |   |   |     |  |   |   |     |  |   |   |     |  |   |   |       |
| 48042F  | Busy tone OFF time: range 3   |          |   |     |   |   |  |  |   |   |     |  |   |   |     |  |   |   |     |  |   |   |       |
| 480430  | Busy tone ON time: range 4  |          |   |     |   |   |  |  |   |   |     |  |   |   |     |  |   |   |     |  |   |   |       |
| 480431  | Busy tone OFF time: range 4   |          |   |     |   |   |  |  |   |   |     |  |   |   |     |  |   |   |     |  |   |   |       |
| 480432  | Busy tone continuous tone detection time  |          |   |     |   |   |  |  |   |   |     |  |   |   |     |  |   |   |     |  |   |   |       |
| 480433  | <p>Busy tone signal state time tolerance for all ranges, and number of cycles required for detection (a setting of 4 cycles means that ON-OFF-ON or OFF-ON-OFF must be detected twice).</p> <p>Bits 7, 6, 5, 4 - number of cycles required for cadence detection<br/>                     Bits 3 and 2 - Not used. Keep these bits at 0.<br/>                     Bits 1 and 0 - Tolerance (±)</p> <table border="0" style="margin-left: 20px;"> <tr> <td>Bit</td> <td>1</td> <td>0</td> <td></td> </tr> <tr> <td></td> <td>0</td> <td>0</td> <td>75%</td> </tr> <tr> <td></td> <td>0</td> <td>1</td> <td>50%</td> </tr> <tr> <td></td> <td>1</td> <td>0</td> <td>25%</td> </tr> <tr> <td></td> <td>1</td> <td>1</td> <td>12.5%</td> </tr> </table> |          |   | Bit | 1 | 0 |  |  | 0 | 0 | 75% |  | 0 | 1 | 50% |  | 1 | 0 | 25% |  | 1 | 1 | 12.5% |
| Bit     | 1   | 0        |   |     |   |   |  |  |   |   |     |  |   |   |     |  |   |   |     |  |   |   |       |
|         | 0   | 0        | 75%   |     |   |   |  |  |   |   |     |  |   |   |     |  |   |   |     |  |   |   |       |
|         | 0   | 1        | 50%   |     |   |   |  |  |   |   |     |  |   |   |     |  |   |   |     |  |   |   |       |
|         | 1   | 0        | 25%   |     |   |   |  |  |   |   |     |  |   |   |     |  |   |   |     |  |   |   |       |
|         | 1   | 1        | 12.5%   |     |   |   |  |  |   |   |     |  |   |   |     |  |   |   |     |  |   |   |       |

| Address | Function  | Unit     | Remarks  |
|---------|---|----------|--|
| 480434  | International dial tone frequency upper limit (high byte)               | Hz (BCD) | If both addresses contain FF(F), tone detection is disabled.   |
| 480435  | International dial tone frequency upper limit (low byte)                |          |  |
| 480436  | International dial tone frequency lower limit (high byte)               | Hz (BCD) | If both addresses contain FF(F), tone detection is disabled.   |
| 480437  | International dial tone frequency lower limit (low byte)                |          |  |
| 480438  | International dial tone detection time                                  | 20 ms    | If 480438 contains FF, the machine pauses for the pause time (48043D / 48043E).<br><br>See Note 2 (Belgium). |
| 480439  | International dial tone reset time (LOW)                                |          |  |
| 48043A  | International dial tone reset time (HIGH)                               |          |  |
| 48043B  | International dial tone continuous tone time                            |          |  |
| 48043C  | International dial tone permissible drop time                           |          |  |
| 48043D  | International dial wait interval (HIGH)                                 |          |  |
| 48043E  | International dial wait interval (LOW)                                  |          |  |
| 48043F  | Country dial tone upper frequency limit (HIGH)                          | Hz (BCD) | If both addresses contain FF(F), tone detection is disabled.   |
| 480440  | Country dial tone upper frequency limit (LOW)                           |          |  |
| 480441  | Country dial tone lower frequency limit (HIGH)                          |          |  |
| 480442  | Country dial tone lower frequency limit (LOW)                           |          |  |
| 480443  | Country dial tone detection time  | 20 ms    | If 480443 contains FF, the machine pauses for the pause time (480448 / 480449).                              |
| 480444  | Country dial tone reset time (LOW)                                      |          |  |
| 480445  | Country dial tone reset time (HIGH)                                     |          |  |
| 480446  | Country dial tone continuous tone time                                  |          |  |
| 480447  | Country dial tone permissible drop time                                 |          |  |
| 480448  | Country dial wait interval (LOW)  |          |  |
| 480449  | Country dial wait interval (HIGH)                                       |          |  |
| 48044A  | Time between opening or closing the DO relay and opening the OHDI relay | 1 ms     | See Notes 3 and 6. Function 06-2 (parameter 11).   |
| 48044B  | Break time for pulse dialling   | 1 ms     | See Note 3. Function 06-2 (parameter 12).  |
| 48044C  | Make time for pulse dialling  | 1 ms     | See Note 3. Function 06-2 (parameter 13).  |
| 48044D  | Time between final OHDI relay closure and DO relay opening or closing   | 1 ms     | See Notes 6. Function 06-2 (parameter 14).   |

| Address | Function   | Unit        | Remarks  |       |       |       |     |   |   |   |       |   |   |   |       |   |   |   |       |   |   |   |       |   |   |   |       |
|---------|--|-------------|--|-------|-------|-------|-----|---|---|---|-------|---|---|---|-------|---|---|---|-------|---|---|---|-------|---|---|---|-------|
| 48044E  | Minimum pause between dialled digits (pulse dial mode)   | 20 ms       | See Note 3. Function 06-2 (parameter 15).  |       |       |       |     |   |   |   |       |   |   |   |       |   |   |   |       |   |   |   |       |   |   |   |       |
| 48044F  | Time waited when a pause is entered at the operation panel   |             | Function 06-2 (parameter 16).  |       |       |       |     |   |   |   |       |   |   |   |       |   |   |   |       |   |   |   |       |   |   |   |       |
| 480450  | DTMF tone on time  | 1 ms        | Function 06-2 (parameter 17).  |       |       |       |     |   |   |   |       |   |   |   |       |   |   |   |       |   |   |   |       |   |   |   |       |
| 480451  | DTMF tone off time   |             | Function 06-2 (parameter 18).  |       |       |       |     |   |   |   |       |   |   |   |       |   |   |   |       |   |   |   |       |   |   |   |       |
| 480452  | Tone attenuation level of DTMF signals while dialing   | -dBm x 0.5  | Function 06-2 (parameter 19). See Note 5.  |       |       |       |     |   |   |   |       |   |   |   |       |   |   |   |       |   |   |   |       |   |   |   |       |
| 480453  | Tone attenuation value difference between high frequency tone and low frequency tone in DTMF signals   | -Nx0.5 (dB) | Function 06-2 (parameter 20). See Note 5.  |       |       |       |     |   |   |   |       |   |   |   |       |   |   |   |       |   |   |   |       |   |   |   |       |
| 480454  | PSTN: DTMF tone attenuation level after dialling   | -dBm x 0.5  | Function 06-2 (parameter 21). See Note 5.  |       |       |       |     |   |   |   |       |   |   |   |       |   |   |   |       |   |   |   |       |   |   |   |       |
| 480455  | ISDN: DTMF tone attenuation level after dialling   | -dBm x 0.5  | See Note 5   |       |       |       |     |   |   |   |       |   |   |   |       |   |   |   |       |   |   |   |       |   |   |   |       |
| 480456  | Not used   |             | Do not change the setting.   |       |       |       |     |   |   |   |       |   |   |   |       |   |   |   |       |   |   |   |       |   |   |   |       |
| 480457  | Not used   |             | Do not change the setting.   |       |       |       |     |   |   |   |       |   |   |   |       |   |   |   |       |   |   |   |       |   |   |   |       |
| 480458  | Not used   |             | Do not change the setting.   |       |       |       |     |   |   |   |       |   |   |   |       |   |   |   |       |   |   |   |       |   |   |   |       |
| 480459  | Grounding time (ground start mode)   | 20 ms       | The Gs relay is closed for this interval.  |       |       |       |     |   |   |   |       |   |   |   |       |   |   |   |       |   |   |   |       |   |   |   |       |
| 48045A  | Break time (flash start mode)  | 1 ms        | The OHD1 relay is open for this interval.  |       |       |       |     |   |   |   |       |   |   |   |       |   |   |   |       |   |   |   |       |   |   |   |       |
| 48045B  | International dial access code (High)  | BCD         | For a code of 100:<br>48045B - F1<br>48045C - 00   |       |       |       |     |   |   |   |       |   |   |   |       |   |   |   |       |   |   |   |       |   |   |   |       |
| 48045C  | International dial access code (Low)   |             |  |       |       |       |     |   |   |   |       |   |   |   |       |   |   |   |       |   |   |   |       |   |   |   |       |
| 48045D  | PSTN access pause time   | 20 ms       | This time is waited for each pause input after the PSTN access code. Up to 7 of these can be input. If this address contains FF[H], the pause time stored in address 48044F is used. |       |       |       |     |   |   |   |       |   |   |   |       |   |   |   |       |   |   |   |       |   |   |   |       |
| 48045E  | <p>Bits 7 to 5 - Progress tone detection level</p> <table border="0"> <tr> <td>Bit 7</td> <td>Bit 6</td> <td>Bit 5</td> <td>dBm</td> </tr> <tr> <td>0</td> <td>0</td> <td>0</td> <td>-25.0</td> </tr> <tr> <td>0</td> <td>0</td> <td>1</td> <td>-35.0</td> </tr> <tr> <td>0</td> <td>1</td> <td>0</td> <td>-30.0</td> </tr> <tr> <td>1</td> <td>0</td> <td>0</td> <td>-40.0</td> </tr> <tr> <td>1</td> <td>1</td> <td>0</td> <td>-49.0</td> </tr> </table> <p>Bits 4 and 3 - Not used</p> <p>Bit 2 - International dial tone detection method<br/>                     0: Detect by time parameters<br/>                     1: Detect by cadence parameters (Belgium - See Note 3)</p> <p>Bit 1 - Not used</p> <p>Bit 0 - PSTN dial tone detection method<br/>                     0: Detect by time parameters<br/>                     1: Detect by cadence parameters (Italy - See Note 3)</p> |             |  | Bit 7 | Bit 6 | Bit 5 | dBm | 0 | 0 | 0 | -25.0 | 0 | 0 | 1 | -35.0 | 0 | 1 | 0 | -30.0 | 1 | 0 | 0 | -40.0 | 1 | 1 | 0 | -49.0 |
| Bit 7   | Bit 6  | Bit 5       | dBm  |       |       |       |     |   |   |   |       |   |   |   |       |   |   |   |       |   |   |   |       |   |   |   |       |
| 0       | 0  | 0           | -25.0  |       |       |       |     |   |   |   |       |   |   |   |       |   |   |   |       |   |   |   |       |   |   |   |       |
| 0       | 0  | 1           | -35.0  |       |       |       |     |   |   |   |       |   |   |   |       |   |   |   |       |   |   |   |       |   |   |   |       |
| 0       | 1  | 0           | -30.0  |       |       |       |     |   |   |   |       |   |   |   |       |   |   |   |       |   |   |   |       |   |   |   |       |
| 1       | 0  | 0           | -40.0  |       |       |       |     |   |   |   |       |   |   |   |       |   |   |   |       |   |   |   |       |   |   |   |       |
| 1       | 1  | 0           | -49.0  |       |       |       |     |   |   |   |       |   |   |   |       |   |   |   |       |   |   |   |       |   |   |   |       |

| Address                | Function   | Unit          | Remarks  |
|------------------------|--|---------------|--|
| 48045F                 | Bit 7 and 6 - Not used<br>Bit 5 1: Polarity detection enabled for rx (detection time = 500 ms)<br>Bit 4 1: Polarity detection enabled for tx (detection time = 500 ms)<br>Bits 3 to 0 - Not used |               |  |
| 480460                 | Not used   |               | Do not change the setting.                     |
| 480461                 | Not used   |               | Do not change the setting.                     |
| 480462                 | Not used   |               | Do not change the setting.                     |
| 480463                 | Not used   |               | Do not change the setting.                     |
| 480464                 | Not used   |               | Do not change the setting.                     |
| 480465                 | Intercity dial prefix (HIGH)   | BCD           | For a code of 0:<br>480465 - FF<br>480466 - F0 |
| 480466                 | Intercity dial prefix (LOW)  | BCD           |  |
| 480467<br>to<br>480471 | Not used   |               | Do not change the settings.                    |
| 480472                 | Acceptable ringing signal frequency: range 1, upper limit  | 1000/ N (Hz). | Function 06-2 (parameter 02).                  |
| 480473                 | Acceptable ringing signal frequency: range 1, lower limit  |               | Function 06-2 (parameter 03).                  |
| 480474                 | Acceptable ringing signal frequency: range 2, upper limit  |               | Function 06-2 (parameter 04).                  |
| 480475                 | Acceptable ringing signal frequency: range 2, lower limit  |               | Function 06-2 (parameter 05).                  |
| 480476                 | Number or rings until a call is detected   | 1             | Function 06-2 (parameter 06).                  |
| 480477                 | Minimum required length of the first ring  | 20 ms         | See Note 4. Function 06-2 (parameter 07).      |
| 480478                 | Minimum required length of the second and subsequent rings   | 20 ms         | Function 06-2 (parameter 06-2).                |
| 480479                 | Ringing signal detection reset time (LOW)  | 20 ms         | Function 06-2 (parameter 09).                  |
| 48047A                 | Ringing signal detection reset time (HIGH)   |               | Function 06-2 (parameter 10).                  |
| 48047B<br>to<br>480480 | Not used   |               | Do not change the settings.                    |
| 480481                 | Interval between dialing the last digit and switching the Oh relay over to the external telephone when dialing from the operation panel in handset mode.   | 20 ms         | Factory setting: 500 ms                        |

| Address                | Function   | Unit             | Remarks  |                           |                |          |                          |                           |        |   |   |      |        |  |       |   |          |            |          |          |                |     |     |   |        |   |     |       |        |  |       |  |          |  |  |
|------------------------|--|------------------|--|---------------------------|----------------|----------|--------------------------|---------------------------|--------|---|---|------|--------|--|-------|---|----------|------------|----------|----------|----------------|-----|-----|---|--------|---|-----|-------|--------|--|-------|--|----------|--|--|
| 480482                 | <p>Bits 0 and 1 - Handset off-hook detection time</p> <table border="0"> <tr> <td><b>Bit</b></td> <td><b>1</b></td> <td><b>0</b></td> <td><b>Setting</b></td> </tr> <tr> <td></td> <td>0</td> <td>0</td> <td>200 ms</td> </tr> <tr> <td></td> <td>0</td> <td>1</td> <td>800 ms</td> </tr> <tr> <td></td> <td>Other</td> <td></td> <td>Not used</td> </tr> </table> <p>Bits 2 and 3 - Handset on-hook detection time</p> <table border="0"> <tr> <td><b>Bit</b></td> <td><b>3</b></td> <td><b>2</b></td> <td><b>Setting</b></td> </tr> <tr> <td></td> <td>0</td> <td>0</td> <td>200 ms</td> </tr> <tr> <td></td> <td>0</td> <td>1</td> <td>800 ms</td> </tr> <tr> <td></td> <td>Other</td> <td></td> <td>Not used</td> </tr> </table> <p>Bits 4 to 7 - Not used</p>                             | <b>Bit</b>       | <b>1</b>   | <b>0</b>                  | <b>Setting</b> |          | 0                        | 0                         | 200 ms |   | 0 | 1    | 800 ms |  | Other |   | Not used | <b>Bit</b> | <b>3</b> | <b>2</b> | <b>Setting</b> |     | 0   | 0 | 200 ms |   | 0   | 1     | 800 ms |  | Other |  | Not used |  |  |
| <b>Bit</b>             | <b>1</b>   | <b>0</b>         | <b>Setting</b>   |                           |                |          |                          |                           |        |   |   |      |        |  |       |   |          |            |          |          |                |     |     |   |        |   |     |       |        |  |       |  |          |  |  |
|                        | 0  | 0                | 200 ms   |                           |                |          |                          |                           |        |   |   |      |        |  |       |   |          |            |          |          |                |     |     |   |        |   |     |       |        |  |       |  |          |  |  |
|                        | 0  | 1                | 800 ms   |                           |                |          |                          |                           |        |   |   |      |        |  |       |   |          |            |          |          |                |     |     |   |        |   |     |       |        |  |       |  |          |  |  |
|                        | Other  |                  | Not used   |                           |                |          |                          |                           |        |   |   |      |        |  |       |   |          |            |          |          |                |     |     |   |        |   |     |       |        |  |       |  |          |  |  |
| <b>Bit</b>             | <b>3</b>   | <b>2</b>         | <b>Setting</b>   |                           |                |          |                          |                           |        |   |   |      |        |  |       |   |          |            |          |          |                |     |     |   |        |   |     |       |        |  |       |  |          |  |  |
|                        | 0  | 0                | 200 ms   |                           |                |          |                          |                           |        |   |   |      |        |  |       |   |          |            |          |          |                |     |     |   |        |   |     |       |        |  |       |  |          |  |  |
|                        | 0  | 1                | 800 ms   |                           |                |          |                          |                           |        |   |   |      |        |  |       |   |          |            |          |          |                |     |     |   |        |   |     |       |        |  |       |  |          |  |  |
|                        | Other  |                  | Not used   |                           |                |          |                          |                           |        |   |   |      |        |  |       |   |          |            |          |          |                |     |     |   |        |   |     |       |        |  |       |  |          |  |  |
| 480483<br>to<br>4804A0 | Not used   |                  | Do not change the settings.                                  |                           |                |          |                          |                           |        |   |   |      |        |  |       |   |          |            |          |          |                |     |     |   |        |   |     |       |        |  |       |  |          |  |  |
| 4804A1                 | Acceptable CED detection frequency upper limit (high byte)   | BCD (Hz)         | If both addresses contain FF(F), tone detection is disabled. |                           |                |          |                          |                           |        |   |   |      |        |  |       |   |          |            |          |          |                |     |     |   |        |   |     |       |        |  |       |  |          |  |  |
| 4804A2                 | Acceptable CED detection frequency upper limit (low byte)  |                  |  |                           |                |          |                          |                           |        |   |   |      |        |  |       |   |          |            |          |          |                |     |     |   |        |   |     |       |        |  |       |  |          |  |  |
| 4804A3                 | Acceptable CED detection frequency lower limit (high byte)   | BCD (Hz)         | If both addresses contain FF(F), tone detection is disabled. |                           |                |          |                          |                           |        |   |   |      |        |  |       |   |          |            |          |          |                |     |     |   |        |   |     |       |        |  |       |  |          |  |  |
| 4804A4                 | Acceptable CED detection frequency lower limit (low byte)  |                  |  |                           |                |          |                          |                           |        |   |   |      |        |  |       |   |          |            |          |          |                |     |     |   |        |   |     |       |        |  |       |  |          |  |  |
| 4804A5                 | CED detection time   | 20 ms<br>± 20 ms | Factory setting: 200 ms                                      |                           |                |          |                          |                           |        |   |   |      |        |  |       |   |          |            |          |          |                |     |     |   |        |   |     |       |        |  |       |  |          |  |  |
| 4804A6                 | Acceptable CNG detection frequency upper limit (high byte)   | BCD (Hz)         | If both addresses contain FF(F), tone detection is disabled. |                           |                |          |                          |                           |        |   |   |      |        |  |       |   |          |            |          |          |                |     |     |   |        |   |     |       |        |  |       |  |          |  |  |
| 4804A7                 | Acceptable CNG detection frequency upper limit (low byte)  |                  |  |                           |                |          |                          |                           |        |   |   |      |        |  |       |   |          |            |          |          |                |     |     |   |        |   |     |       |        |  |       |  |          |  |  |
| 4804A8                 | Acceptable CNG detection frequency lower limit (high byte)   | BCD (Hz)         | If both addresses contain FF(F), tone detection is disabled. |                           |                |          |                          |                           |        |   |   |      |        |  |       |   |          |            |          |          |                |     |     |   |        |   |     |       |        |  |       |  |          |  |  |
| 4804A9                 | Acceptable CNG detection frequency lower limit (low byte)  |                  |  |                           |                |          |                          |                           |        |   |   |      |        |  |       |   |          |            |          |          |                |     |     |   |        |   |     |       |        |  |       |  |          |  |  |
| 4804AA                 | CNG detection time   | 20 ms<br>± 20 ms | Factory setting: 200 ms                                      |                           |                |          |                          |                           |        |   |   |      |        |  |       |   |          |            |          |          |                |     |     |   |        |   |     |       |        |  |       |  |          |  |  |
| 4804AB                 | CNG on time  | 20 ms            | Factory setting: 500 ms                                      |                           |                |          |                          |                           |        |   |   |      |        |  |       |   |          |            |          |          |                |     |     |   |        |   |     |       |        |  |       |  |          |  |  |
| 4804AC                 | CNG off time   | 20 ms            | Factory setting: 200 ms                                      |                           |                |          |                          |                           |        |   |   |      |        |  |       |   |          |            |          |          |                |     |     |   |        |   |     |       |        |  |       |  |          |  |  |
| 4804AD                 | <p>CNG On/Off time tolerance, and number of cycles required for detection (a setting of 4 cycles means that ON-OFF-ON or OFF-ON-OFF must be detected twice).</p> <p>Bits 7, 6, 5, 4 - number of cycles required for cadence detection</p> <p>Bits 3 and 2 - Not used. Keep these bit at 0.</p> <p>Bits 1 and 0 - Tolerance (±)</p> <table border="0"> <tr> <td><b>Bit</b></td> <td><b>1</b></td> <td><b>0</b></td> <td><b>ON time tolerance</b></td> <td><b>OFF time tolerance</b></td> </tr> <tr> <td></td> <td>0</td> <td>0</td> <td>150%</td> <td>75%</td> </tr> <tr> <td></td> <td>0</td> <td>1</td> <td>100%</td> <td>50%</td> </tr> <tr> <td></td> <td>1</td> <td>0</td> <td>50%</td> <td>25%</td> </tr> <tr> <td></td> <td>1</td> <td>1</td> <td>25%</td> <td>12.5%</td> </tr> </table> |                  |  | <b>Bit</b>                | <b>1</b>       | <b>0</b> | <b>ON time tolerance</b> | <b>OFF time tolerance</b> |        | 0 | 0 | 150% | 75%    |  | 0     | 1 | 100%     | 50%        |          | 1        | 0              | 50% | 25% |   | 1      | 1 | 25% | 12.5% |        |  |       |  |          |  |  |
| <b>Bit</b>             | <b>1</b>   | <b>0</b>         | <b>ON time tolerance</b>                                     | <b>OFF time tolerance</b> |                |          |                          |                           |        |   |   |      |        |  |       |   |          |            |          |          |                |     |     |   |        |   |     |       |        |  |       |  |          |  |  |
|                        | 0  | 0                | 150%   | 75%                       |                |          |                          |                           |        |   |   |      |        |  |       |   |          |            |          |          |                |     |     |   |        |   |     |       |        |  |       |  |          |  |  |
|                        | 0  | 1                | 100%   | 50%                       |                |          |                          |                           |        |   |   |      |        |  |       |   |          |            |          |          |                |     |     |   |        |   |     |       |        |  |       |  |          |  |  |
|                        | 1  | 0                | 50%  | 25%                       |                |          |                          |                           |        |   |   |      |        |  |       |   |          |            |          |          |                |     |     |   |        |   |     |       |        |  |       |  |          |  |  |
|                        | 1  | 1                | 25%  | 12.5%                     |                |          |                          |                           |        |   |   |      |        |  |       |   |          |            |          |          |                |     |     |   |        |   |     |       |        |  |       |  |          |  |  |
| 4804AE                 | Not used   |                  | Do not change the settings.                                  |                           |                |          |                          |                           |        |   |   |      |        |  |       |   |          |            |          |          |                |     |     |   |        |   |     |       |        |  |       |  |          |  |  |

| Address                | Function  | Unit                          | Remarks  |
|------------------------|---|-------------------------------|--|
| 4804AF                 | Acceptable AI short protocol tone (800Hz) detection frequency upper limit (high byte) | Hz (BCD)                      | If both addresses contain FF(F), tone detection is disabled.   |
| 4804B0                 | Acceptable AI short protocol tone (800Hz) detection frequency upper limit (low byte)  |                               | If both addresses contain FF(F), tone detection is disabled.   |
| 4804B1                 | Acceptable AI short protocol tone (800Hz) detection frequency lower limit (high byte) | Hz(BCD)                       | If both addresses contain FF(F), tone detection is disabled.   |
| 4804B2                 | Acceptable AI short protocol tone (800Hz) detection frequency lower limit (low byte)  |                               | If both addresses contain FF(F), tone detection is disabled.   |
| 4804B3                 | Detection time for 800 Hz AI short protocol tone                                      | 20 ms                         | Factory setting: 360 ms  |
| 4804B4                 | PSTN: Tx level from the modem   | - dBm                         | Function 06-2 (parameter 01).  |
| 4804B5                 | PSTN: 1100 Hz tone transmission level   | - N 4804B4 - 0.5N 4804B5 (dB) |  |
| 4804B6                 | PSTN: 2100 Hz tone transmission level   | - N 4804B4 - 0.5N 4804B6 (dB) |  |
| 4804B7                 | PABX: Tx level from the modem   | - dBm                         |  |
| 4804B8                 | PABX: 1100 Hz tone transmission level   | - N 4804B7 - 0.5N 4804B8 (dB) |  |
| 4804B9                 | PABX: 2100 Hz tone transmission level   | - N 4804B7 - 0.5N 4804B9 (dB) |  |
| 4804BA                 | ISDN: Tx level from the modem   | - dBm                         | The setting must be between -12dBm and -15dBm.   |
| 4804BB                 | ISDN: 1100 Hz tone transmission level   | - N 4804BA - 0.5N 4804BB (dB) |  |
| 4804BC                 | ISDN: 2100 Hz tone transmission level   | - N 4804BA - 0.5N 4804BC (dB) |  |
| 4804BD                 | Modem turn-on level (incoming signal detection level)                                 | -37-0.5N (dBm)                | N must be between 0 (00(H)) to 31 (1F(H)).<br>Modem turn-off level is automatically set at -3dBm from the turn-on level. |
| 4804BE<br>to<br>4804D9 | Not used  |                               | Do not change the settings.  |
| 4804DA                 | T.30 T1 timer   | 1 s                           |  |

## Notes

1. If a setting is not required, store FF in the address.
2. Italy and Belgium only

RAM address 48045E: the lower four bits have the following meaning.

Bit 2 1: International dial tone cadence detection enabled (Belgium)

Bit 1 Not used

Bit 0 1: PSTN dial tone cadence detection enabled (Italy)

If bit 0 or bit 2 is set to 1, the functions of the following RAM addresses are changed.

480408 (if bit 0 = 1) or 480438 (if bit 2 = 1): tolerance for on or off state duration (%), and number of cycles required for detection, coded as in address 480433.

48040B (if bit 0 = 1) or 48043B (if bit 2 = 1): on time, hex code (unit = 20 ms)

48040C (if bit 0 = 1) or 48043C (if bit 2 = 1): off time, hex code (unit = 20 ms)

3. Pulse dial parameters (addresses 48044A to 48044F) are the values for 10 pps. If 20 pps is used, the machine automatically compensates.
4. The first ring may not be detected until 1 to 2.5 wavelengths after the time specified by this parameter.
5. The calculated level must be between 0 and 10.  
The attenuation levels calculated from RAM data are:  
High frequency tone:  $- 0.5 \times N_{480452/480454}$  dBm  
Low frequency tone:  $- 0.5 \times (N_{480452/480454} + N_{480453})$  dBm  
Note:  $N_{480452}$ , for example, means the value stored in address 480452(H)
6. 48044A: Europe - Between Ds opening and Di opening, France - Between Ds closing and Di opening  
48044D: Europe - Between Ds closing and Di closing, France - Between Ds opening and Di closing

---

## 4. DEDICATED TRANSMISSION PARAMETERS

Each Quick Dial Key and Speed Dial Code has four bytes of programmable parameters allocated to it. If transmissions to a particular machine often experience problems, store that terminal's fax number as a Quick Dial or Speed Dial, and adjust the parameters allocated to that number.

The programming procedure will be explained first. Then, the four bytes will be described.

### 4.1 PROGRAMMING PROCEDURE

1. Make sure the machine is in 'Facsimile' mode. Press 'User Tools' key then choose 'Fax'.
2. Press '1', then either choose 'Registering Quick Dial' or 'Registering Speed Dial'.

**Example:** Change the Parameters in Quick Dial 10.

4. Press Quick Dial key 10.

**Note:** The selected Quick or Speed Dial must be programmed beforehand.

5. When the programmed dial number is displayed, press S - V - C using Quick Dial keys, then press 'Start'.
6. The settings for byte 0 are now displayed. Press a number from 0 to 7 corresponding to the bit that you wish to change.

Example: Change bit 7 to 1: Press 7

7. To scroll through the parameter bytes, either:  
Select the next byte: press '↓ Switch'  
or  
Select the previous byte: press '↑ Switch'  
until the correct byte is displayed. Then go back to step 6.
8. After the setting is changed, press OK.
9. To finish, press 'User Tools'.



## 4.2 PARAMETERS

The initial settings of the following parameters are all FF(H) - all the parameters are disabled.

| Switch 01  |  |
|--|--|
| FUNCTION AND COMMENTS  |  |
| CCITT T1 time (for PSTN G3 mode)   |  |
| If the connection time to a particular terminal is longer than the NCU parameter setting , adjust this byte. The T1 time is the value stored in this byte (in hex code), multiplied by 1 second. |  |
| <b>Range:</b>  |  |
| 1 to 127 s (01h to 7Fh)  |  |
| 00h or FFh - The local NCU parameter factory setting is used.  |  |
| Do not program a value between 80h and FEh.  |  |

| Switch 02 |                              |   |
|-----------|------------------------------|---|
|           | FUNCTION                     | COMMENTS  |
| <b>0</b>  | Tx level                     | If communication with a particular remote terminal often contains errors, the signal level may be inappropriate. Adjust the Tx level for communications with that terminal until the results are better.<br><br>When disabled, the NCU parameter 01 setting is used.<br><br><b>Note:</b> Do not use settings other than listed on the left.   |
| <b>to</b> | <b>Bit 4 3 2 1 0 Setting</b> |   |
| <b>4</b>  | 0 0 0 0 0 0                  |   |
|           | 0 0 0 0 1 -1                 |   |
|           | 0 0 0 1 0 -2                 |   |
|           | 0 0 0 1 1 -3                 |   |
|           | 0 0 1 0 0 -4                 |   |
|           | :                            |   |
|           | :                            |   |
|           | 0 1 1 1 1 -15                |   |
|           | 1 1 1 1 1 Disabled           |   |
| <b>5</b>  | Cable equalizer              | Use a higher setting if there is signal loss at higher frequencies because of the length of wire between the modem and the telephone exchange when calling the number stored in this Quick/Speed Dial.<br><br>Also, try using the cable equalizer if one or more of the following symptoms occurs.<br><ul style="list-style-type: none"> <li>•Communication error with error codes such as 0-20, 0-23, etc.</li> <li>•Modem rate fallback occurs frequently.</li> </ul> <b>Note:</b> Do not use settings other than listed on the left. |
| <b>to</b> | <b>Bit 7 6 5 Setting</b>     |   |
| <b>7</b>  | 0 0 0 None                   |   |
|           | 0 0 1 Low                    |   |
|           | 0 1 0 Medium                 |   |
|           | 0 1 1 High                   |   |
|           | 1 1 1 Disabled               |   |

| <b>Switch 03</b> |                                  | <b>FUNCTION</b> | <b>COMMENTS</b>  |
|------------------|----------------------------------|-----------------|--|
| <b>0</b>         | Initial Tx modem rate            |                 | If training with a particular remote terminal always takes too long, the initial modem rate may be too high. Reduce the initial Tx modem rate using these bits.<br><br><b>Note:</b> Do not use settings other than listed on the left. |
| <b>to Bit 3</b>  | <b>Bit 3 2 1 0 Setting (bps)</b> |                 |  |
|                  | 0 0 0 0                          | Not used        |  |
|                  | 0 0 0 1                          | 2,400           |  |
|                  | 0 0 1 0                          | 4,800           |  |
|                  | 0 0 1 1                          | 7,200           |  |
|                  | 0 1 0 0                          | 9,600           |  |
|                  | 0 1 0 1                          | 12,000          |  |
|                  | 0 1 1 0                          | 14,400          |  |
|                  | 1 1 1 1                          | Disabled        |  |
|                  | Other settings:                  | Not used        |  |
| <b>4</b>         | Not used                         |                 | Do not change the settings.  |
| <b>to 7</b>      |                                  |                 |  |

| <b>Switch 04</b> |  | <b>FUNCTION</b>              | <b>COMMENTS</b>  |
|------------------|--|------------------------------|--|
| <b>0</b>         | Inch-mm conversion before tx                                   |                              | The machine uses inch-based resolutions for scanning. If "inch only" is selected, the printed copy may be slightly distorted at the other end if that machine uses mm-based resolutions.                     |
| <b>Bit 1</b>     | <b>Bit 0 Setting</b>   |                              |  |
| <b>1</b>         | 0 0  | Inch-mm conversion available |  |
|                  | 0 1  | Inch only                    |  |
|                  | 1 0  | Not used                     |  |
|                  | 1 1  | Disabled                     |  |
| <b>2</b>         | DIS/NSF detection method                                       |                              | <b>(0, 1):</b> Use this setting if echoes on the line are interfering with the set-up protocol at the start of transmission. The machine will then wait for the second DIS or NSF before sending DCS or NSS. |
| <b>Bit 3</b>     | <b>Bit 2 Setting</b>   |                              |  |
| <b>3</b>         | 0 0  | First DIS or NSF             |  |
|                  | 0 1  | Second DIS or NSF            |  |
|                  | 1 0  | Not used                     |  |
|                  | 1 1  | Disabled                     |  |
| <b>4</b>         | Not used   |                              | Do not change the settings.  |
| <b>5</b>         | Compression modes available in transmit mode                   |                              | This bit determines the capabilities that are informed to the other terminal during transmission.  |
|                  | <b>0:</b> MH only<br><b>1:</b> All available compression modes |                              |  |
| <b>6</b>         | ECM during transmission  |                              | For example, if ECM is switched on but is not wanted when sending to a particular terminal, use the (0, 0) setting.  |
| <b>Bit 7</b>     | <b>Bit 6 Setting</b>   |                              |  |
| <b>7</b>         | 0 0  | Disabled                     |  |
|                  | 0 1  | Enabled                      |  |
|                  | 1 0  | Not used                     |  |
|                  | 1 1  | Disabled                     |  |

**Service  
Tables and  
Procedures**

| <b>Switch 05 - Optional ISDN G4 kit required</b> |                 |          |          |          |          |  |                |
|--|-----------------|----------|----------|----------|----------|--|----------------|
|  | <b>FUNCTION</b> |          |          |          |          | <b>COMMENTS</b>  |                |
| <b>0</b>   | Data rate       |          |          |          |          | When disabled, the G4 parameter switch 2 (bits 0 and 1) setting is used. |                |
| <b>to</b>  | <b>Bits</b>     | <b>3</b> | <b>2</b> | <b>1</b> | <b>0</b> |  | <b>Setting</b> |
| <b>3</b>   |                 | 0        | 0        | 0        | 0        |  | 64 kbps        |
|  |                 | 0        | 0        | 0        | 1        |  | 56 kbps        |
|  |                 | 1        | 1        | 1        | 1        | Disabled   |                |
| <b>4</b>   | Not used        |          |          |          |          | Do not change the settings.  |                |
| <b>to</b>  |                 |          |          |          |          |  |                |
| <b>7</b>   |                 |          |          |          |          |  |                |

| <b>Switch 06 - Optional ISDN G4 kit required</b> |                 |          |          |          |          |   |                |
|--|-----------------|----------|----------|----------|----------|---|----------------|
|  | <b>FUNCTION</b> |          |          |          |          | <b>COMMENTS</b>   |                |
| <b>0</b>   | Link Modules    |          |          |          |          | When disabled, the G4 parameter switch 3 (bit 0) setting is used. |                |
| <b>to</b>  | <b>Bits</b>     | <b>3</b> | <b>2</b> | <b>1</b> | <b>0</b> |   | <b>Setting</b> |
| <b>3</b>   |                 | 0        | 0        | 0        | 0        |   | Modulo 8       |
|  |                 | 0        | 0        | 0        | 1        |   | Modulo 128     |
|  |                 | 1        | 1        | 1        | 1        | Disabled  |                |
| <b>4</b>   | Not used        |          |          |          |          | Do not change the settings.                                       |                |
| <b>to</b>  |                 |          |          |          |          |   |                |
| <b>7</b>   |                 |          |          |          |          |   |                |

| <b>Switch 07 - Optional ISDN G4 kit required</b> |                  |          |          |          |          |   |                |
|--|------------------|----------|----------|----------|----------|---|----------------|
|  | <b>FUNCTION</b>  |          |          |          |          | <b>COMMENTS</b>   |                |
| <b>0</b>   | Layer 3 protocol |          |          |          |          | When disabled, the G4 parameter switch 6 (bit 0) setting is used. |                |
| <b>to</b>  | <b>Bits</b>      | <b>3</b> | <b>2</b> | <b>1</b> | <b>0</b> |   | <b>Setting</b> |
| <b>3</b>   |                  | 0        | 0        | 0        | 0        |   | ISO 8208       |
|  |                  | 0        | 0        | 0        | 1        |   | T.70 NULL      |
|  |                  | 1        | 1        | 1        | 1        | Disabled  |                |
| <b>4</b>   | Packet modules   |          |          |          |          | When disabled, the G4 parameter switch 6 (bit 4) setting is used. |                |
| <b>to</b>  | <b>Bits</b>      | <b>3</b> | <b>2</b> | <b>1</b> | <b>0</b> |   | <b>Setting</b> |
| <b>7</b>   |                  | 0        | 0        | 0        | 0        |   | Modulo 9       |
|  |                  | 0        | 0        | 0        | 1        |   | Modulo 128     |
|  |                  | 1        | 1        | 1        | 1        | Disabled  |                |

**Switch 08 - Not used**

## 5. SERVICE RAM ADDRESSES

### CAUTION

**Do not change the settings which are marked as “Not used” or “Read only.”**

**004000 to 004011(H)** - ROM part number and suffix (ASCII)

**004017 to 00402A(H)** - ROM version and release date (ASCII)

**348604 to 34A223(H)** - Dedicated tx parameters for Speed Dial #100 - #999, when a Function Upgrade Card is used.

As explained in Dedicated Transmission parameters in section 4, each set of dedicated tx parameters consists of 8 bytes.

348604 to 34860B(H) - Dedicated tx parameters for Speed #100

34860C to 348613(H) - Dedicated tx parameters for Speed #101

348614 to 34861B(H) - Dedicated tx parameters for Speed #102



34A21C to 34A223(H) - Dedicated tx parameters for Speed #999

**480001 to 480004(H)** - ROM version (Read only)

480001(H) - Revision number (BCD)

480002(H) - Year (BCD)

480003(H) - Month (BCD)

480004(H) - Day (BCD)

**480006 to 480015(H)** - Machine's serial number (16 digits - ASCII)

**480018(H)** - Total program checksum (low)

**480019(H)** - Total program checksum (high)

**48001A(H)** - Boot program checksum (low)

**48001B(H)** - Boot program checksum (high)

**48001C(H)** - Main program checksum (low)

**48001D(H)** - Main program checksum (high)

**480020 to 48003F(H)** - System bit switches

**480040 to 48004F(H)** - Scanner bit switches

**480050 to 48005F(H)** - Printer bit switches

**480060 to 48007F(H)** - Communication bit switches

**480080 to 48008F(H)** - G3 bit switches

**4800A0(H) - User parameter switch 00 (SWUER\_00)**

Bit 0: Stamp home position 0: Disabled, 1: Enabled

Bits 1 to 3: Scanning contrast home position

| Bit | 3 | 2 | 1 | Setting               |
|-----|---|---|---|-----------------------|
|     | 0 | 0 | 0 | Automatic             |
|     | 0 | 0 | 1 | Position 1 (Lightest) |
|     | 0 | 1 | 0 | Position 2            |
|     | 0 | 1 | 1 | Position 3            |
|     | 1 | 0 | 0 | Position 4 (Medium)   |
|     | 1 | 0 | 1 | Position 5            |
|     | 1 | 1 | 0 | Position 6            |
|     | 1 | 1 | 1 | Position 7 (Darkest)  |

Bits 4 and 5: Scanning resolution home position

| Bit | 5 | 4 | Setting   |
|-----|---|---|-----------|
|     | 0 | 0 | Standard  |
|     | 0 | 1 | Detail    |
|     | 1 | 0 | Superfine |
|     | 1 | 1 | Superfine |

Bit 6: Transmission mode home position 0: Memory tx, 1: Immediate tx

Bit 7: Not used

**4800A1(H) - User parameter switch 01 (SWUSR\_01)**

Bit 0: Label insertion home position 0: Disabled, 1: Enabled

Bit 1: ID transmission home position 0: Disabled, 1: Enabled

Bit 2: Automatic reduction (tx) home position 0: Disabled, 1: Enabled

Bits 3 and 4: Scanning mode LED home position

| Bit | 4 | 3 | Setting     |
|-----|---|---|-------------|
|     | 0 | 0 | Text        |
|     | 0 | 1 | Text/ Photo |
|     | 1 | 0 | Photo       |
|     | 1 | 1 | Photo       |

Bit 5: TTI print home position 0: Disabled, 1: Enabled

Bit 6: Not used

Bit 7: Settings return to home position after scanning 0: Disabled, 1: Enabled

**4800A2(H) - User parameter switch 02 (SWUSR\_02)**

Bit 0: Forwarding mark printing on forwarded messages 0: Disabled, 1: Enabled

Bit 1: Center mark printing on received copies 0: Disabled, 1: Enabled

Bit 2: Reception time printing 0: Disabled, 1: Enabled

Bit 3: TSI print on received messages 0: Disabled, 1: Enabled

Bit 4: Checkered mark printing 0: Disabled, 1: Enabled

Bit 5: CIL printing (G4) 0: Disabled, 1: Enabled

Bit 6: TID printing (G4) 0: Disabled, 1: Enabled

Bit 7: Not used

**4800A3(H) - User parameter switch 03 (SWUSR\_03: Automatic report printout)**

Bit 0: Transmission result report (memory transmissions) 0: Off, 1: On

Bit 1: Not used

Bit 2: Memory storage report 0: Off, 1: On

Bit 3: Polling reserve report (polling reception) 0: Off, 1: On

Bit 4: Polling result report (polling reception) 0: Off, 1: On

Bit 5: Transmission result report (immediate transmissions) 0: Off, 1: On

Bit 6: Polling clear report 0: Off, 1: On

Bit 7: TCR (Journal) 0: Off, 1: On



**4800A4(H) - User parameter switch 04 (SWUSR\_04: Automatic report printout)**

Bit 0: Automatic confidential reception report output 0: Off, 1: On

Bits 1 to 6: Not used

Bit 7: Inclusion of a sample image on reports 0: Off, 1: On

**4800A5(H) - User parameter switch 05 (SWUSR\_05)**

Bit 0: Substitute reception when the base copier is in SC condition 0: Off, 1: On

Bits 1 and 2: Condition for substitute rx when the machine cannot print messages (Paper end, Toner end, and Jam in 3.5W energy saver mode)

| Bit | 2 | 1 | Setting   |
|-----|---|---|---|
|     | 0 | 0 | The machine receives all the fax messages                   |
|     | 0 | 1 | The machine receives the fax messages with RTI or CSI       |
|     | 1 | 0 | The machine receives the fax messages with the same ID code |
|     | 1 | 1 | The machine does not receive anything.                      |

Bit 3: Not used

Bit 4: Restricted Access using personal code 0: Off, 1: On

Bits 5 to 7: Not used

**4800A6(H) - User parameter switch 06 (SWUSR\_06)**

Bit 0: Not used

Bit 1: G3/G4 LED home position 0: G3, 1: G4

Bit 2 to 7: Not used

**4800A7(H) - User parameter switch 07 (SWUSR\_07)**

Bits 0 and 1: Not used

Bit 2: Parallel memory transmission 0: Off, 1: On

Bits 3 and 7: Not used

**4800A8(H) - User parameter switch 08 (SWUSR\_08)**

Bit 0 and 1: Not used.

Bit 2: Authorized reception

0: Only faxes from senders whose RTIs/CSIs are specified for this feature are accepted.

1: Only faxes from senders whose RTIs/CSIs are not specified for this feature are accepted.

Bits 3 to 7: Not used.

**4800A9(H) - User parameter switch 09 (SWUSR\_09)**

Bits 0 to 7: Not used

**4800AA(H) - User parameter switch 10 (SWUSR\_0A)**

Bit 0: Not used

Bit 1: 2 into 1 0: Off, 1: On

Bit 2: Not used

Bit 3: Page reduction 0: Off, 1: On

Bits 4 to 7: Not used

**4800AB(H) - User parameter switch 11 (SWUSR\_0B)**

Bit 0: Not used

Bit 1: Method of transmitting numbers after the "Tone" mark over an ISDN line

0: UUI, 1: Tone

Bits 2 to 5: Not used

Bit 6: Printout of messages received while acting as a forwarding station 0: Off, 1: On

Bit 7: Polling Standby duration 0: Once, 1: No limit

**4800AC(H) - User parameter switch 12 (SWUSR\_0C)**

Bits 0 and 2: Not used

Bits 3 and 4: Printout image density (Fax mode)

|     |   |   |          |
|-----|---|---|----------|
| Bit | 4 | 3 | Setting  |
|     | 0 | 0 | Normal   |
|     | 0 | 1 | Lighten  |
|     | 1 | 0 | Darken   |
|     | 1 | 1 | Not used |

Bits 5 to 7: Not used

**4800AD(H) - PSTN access method (SWUSR\_0D)**

Bits 0 and 1: PSTN access method from behind a PABX

|     |   |   |              |
|-----|---|---|--------------|
| Bit | 1 | 0 | Setting      |
|     | 0 | 0 | PSTN         |
|     | 0 | 1 | Loop start   |
|     | 1 | 0 | Ground start |
|     | 1 | 1 | Flash start  |

Bits 2 to 7: Not used

**4800AE(H) - Function settings (SWUSR\_0E)**

Bit 0: Message printout while the machine is in Night Timer mode

0: On, 1: Off

Bit 1: Long original feed mode 0: Off, 1: On

Bit 2: Batch transmission 0: Off, 1: On



Bits 3 to 6: Not used

Bit 7: Manual service call (system parameter list tx) 0: Off, 1: On

**4800AF(H) - Function settings (SWUSR\_0F)**

Bits 0, 1 and 2: Cassette for fax printout

|     |   |   |   |                        |
|-----|---|---|---|------------------------|
| Bit | 2 | 1 | 0 | Setting                |
|     | 0 | 0 | 1 | 1st paper feed station |
|     | 0 | 1 | 0 | 2nd paper feed station |
|     | 0 | 1 | 1 | 3rd paper feed station |
|     | 1 | 0 | 0 | 4th paper feed station |

Other settings Not used

Bits 3 and 4: Not used

Bit 5: Using the cassette specified by bits 0, 1 and 2 above only 0: On, 1: Off

Bits 6 and 7: Not used

**4800B8(H) - Function settings (SWUSR\_18)**

Bits 0 and 1: File retention time

|     |   |   |          |
|-----|---|---|----------|
| Bit | 1 | 0 | Setting  |
|     | 0 | 0 | Disabled |
|     | 0 | 1 | 24 hours |
|     | 1 | 0 | Disabled |
|     | 1 | 1 | 72 hours |

Bits 2 to 7: Not used

**4800B9(H) - Function settings (SWUSR\_19)**

Bits 0 to 3: Not used

Bit 4: RDS operation 0: Not acceptable

1: Acceptable for the limit specified by system switch 03

**Note:** This bit is only effective when RDS operation can be selectable by user.

Bits 5 and 6: Not used

Bit 7: Daylight saving time 0: Disabled, 1: Enabled

**4800BA(H) - Function settings (SWUSR\_1A)**

Bit 0: Not used

Bit 1: Dialing type 0: Pulse dialing (10 pps), 1: Tone (DTMF) dialing

Bits 2 to 7: Not used

**4800BB(H) - PSTN access number from behind PABX (SWUSR\_1B)**

Access number Hex value to program (BCD)

|    |    |
|----|----|
| 0  | F0 |
| ↓  | ↓  |
| 0  | F0 |
| 00 | 00 |
| ↓  | ↓  |
| 99 | 99 |

**4800C0 to 4800CF(H) - G4 Parameter Switches**

(Refer to the ISDN G4 option service manual for details.)

**4800D0 to 4800EF(H) - G4 Internal Switches**

(Refer to the ISDN G4 option service manual for details.)

**4800F0 to 480103(H) - RTI (Max. 20 characters - ASCII) - See the following note.****480104 to 480117(H) - CSI (Max. 20 characters - ASCII)****480118 to 800137(H) - TTI (Max. 32 characters - ASCII) - See the following note.****480138(H) - Number of CSI characters (Hex)****Note:** If the number of characters are less than the maximum (20 for RTI, 32 for TTI), add a stop code (FF[H]) after the last character.**480139 to 480147(H) - Service station's fax number (Service mode 09)****See 48018F(H) for the type of network used for this number.****480157 to 480165(H) - Own fax number (PSTN)****480166 to 480174(H) - Own fax number (ISDN G4)****480175 to 480183(H) - Own fax number (ISDN G3)****480184(H) - ID code (low - Hex)****480185(H) - ID code (high - Hex)****480186(H) - Confidential ID (low - BCD)****480187(H) - Confidential ID (high - BCD)****480188(H) - Memory lock ID (low - Hex)****480189(H) - Memory lock ID (high - Hex)****48018F(H) - Network type used for the service station number**

00(H) - G3 (PSTN)

01(H) - G4 (ISDN)

**480198 to 48019F(H) - Last power off time (Read only)**

480198(H) - 01(H) - 24-hour clock, 00(H) - 12-hour clock (AM), 02(H) - 12-hour clock (PM)

480199(H) - Year (BCD)

48019A(H) - Month (BCD)

48019B(H) - Day (BCD)

48019C(H) - Hour

48019D(H) - Minute

48019E(H) - Second

48019F(H) - 00: Monday, 01: Tuesday, 02: Wednesday, ..... , 06: Sunday



**4801AC(H) - Optional equipment (Read only)**

Bit 0: Page memory card                      0: Not installed, 1: Installed  
 Bit 1: SAF memory card 2M                 0: Not installed, 1: Installed  
 Bit 2: SAF memory card 4M                 0: Not installed, 1: Installed  
 Bit 3: Not used  
 Bit 4: Hard disk                                0: Not installed, 1: Installed  
 Bit 5: Function upgrade card                0: Not installed, 1: Installed  
 Bit 6: ISDN unit                               0: Not installed, 1: Installed  
 Bit 7: Not used

**4801C0 to 4801C2(H) - Tx counter**

| Address   | High                    | Low                 |
|-----------|-------------------------|---------------------|
| 4801C0(H) | Tens digit              | Unit digit          |
| 4801C1(H) | Thousands digit         | Hundreds digit      |
| 4801C2(H) | Hundred thousands digit | Ten thousands digit |

**4801C4 to 4801C6(H) - Rx counter (the format is the same as for the tx counter)**

**4802AE to 4802C5(H) - G4 terminal ID (ASCII - Max. 24 characters)**

**4802C6 to 4802D9(H) - ISDN G3 CSI (ASCII - Max. 20 digits)**

**4802DA(H) - Number of digits programmed in the ISDN G3 CSI (Hex)**

**4802DB to 4802DE(H) - ISDN IP**

**4802DF to 4802E2(H) - ISDN G3 sub-address**

**4802E3 to 4802E6(H) - ISDN G4 sub-address**

**4802E7 to 4802EB(H) - CiG4 board ROM information**

4802E7(H) - Suffix  
 4802E8(H) - Version (BCD)  
 4802E9(H) - Year (BCD)  
 4802EA(H) - Month (BCD)  
 4802EB(H) - Day (BCD)

**480300(H) - Number of copies for multi-sort document reception**

**480356(H) - Time for economy transmission (hour in 24h clock format - BCD)**

**480357(H) - Time for economy transmission (minute - BCD)**

**480372(H) - Transmission monitor volume            00 - 07(H)**

**480373(H) - Reception monitor volume             00 - 07(H)**

**480374(H) - On-hook monitor volume               00 - 07(H)**

**480375(H) - Dialing monitor volume               00 - 07(H)**

**480376(H) - Buzzer volume                         00 - 07(H)**

**480379 to 48037D(H) - Periodic service call parameters (Refer to section 2.1.2 for details)**

**480383 to 480385(H) - Effective term of automatic service calls (Refer to section 2.1.4 for details)**

**480400 to 4804DA(H) - NCU parameters (Refer to section 4.3 for details)**

**492D00 to 4931DF(H)** - Dedicated tx parameters for Quick Dial 01 - 56 and Speed Dial #00 - #99.

As explained in section 4.4, each set of dedicated tx parameters consists of 8 bytes.

492D00 to 492D07(H) - Dedicated tx parameters for Quick 01

492D08 to 492D0F(H) - Dedicated tx parameters for Quick 02

492D10 to 492D17(H) - Dedicated tx parameters for Quick 03

↓

492EB8 to 492EBF(H) - Dedicated tx parameters for Quick 56

492EC0 to 492EC7(H) - Dedicated tx parameters for Speed #00

492EC8 to 492ECFH) - Dedicated tx parameters for Speed #01

492ED0 to 492ED7(H) - Dedicated tx parameters for Speed #03

↓

4931D8 to 4931DF(H) - Dedicated tx parameters for Speed #99

#### **49B9F6 to 49BB75(H) - Latest 64 error codes (Read only)**

One error record consists of 6 bytes of data.

First error record start address - 49B9F6(H)

Second error record start address - 49B9FC(H)

Third error record start address - 49BA02(H)

: : :

64th error record start address - 49BB70(H)

The format is as follows:

1st byte - Minute (BCD)

2nd byte - Hour (BCD)

3rd byte - Day (BCD)

4th byte - Month (BCD)

5th byte - Error code (low) [If the error code is 1-23, 23 is stored here.]

6th byte - Error code (high) [If the error code is 1-23, 01 is stored here.]

#### **49E976 to 49F055(H) - Latest 20 error communication records (Read only)**

One error communication record consists of 88 bytes. The format is as follows:

1st byte - Header

Bit 0: Communication result      0: OK, 1: NG

Bit 1: Document jam                1: Occurred

Bit 2: Power down                 1: Occurred

Bit 3: Not used

Bit 4: Technical data printout instead of personal codes    0: No, 1: Yes

Bit 5: Type of technical data      0: Rx level, 1: Measure of error rate

Bit 6: Error report                 0: Not printed, 1: Printed

Bit 7: Data validity                0: Not valid, 1: Valid

2nd byte - Not used

3rd to 6th bytes - Date and time when the communication started

3rd byte - Month (BCD)

4th byte - Day (BCD)

5th byte - Hour (BCD)

6th byte - Minute (BCD)

7th and 8th bytes - Communication time

7th byte - Minutes (BCD)

8th byte - Seconds (BCD)

9th and 10th byte - Number of pages transmitted or received

9th byte - Low byte (Hex)

10th byte - High byte (Hex)

11th and 12th bytes - Personal code or number of total/burst error lines

If bit 4 of the 1st byte is 0:

11th byte - Personal code (low - BCD)

12th byte - Personal code (high - BCD)

If bit 4 of the 1st byte is 1:

11th byte - Number of total error lines (Hex)

12th byte - Number of burst error lines (Hex)

13th byte - File number (low - Hex)

14th byte - File number (high - Hex)

15th and 16th bytes - Rx level or measure of error rate

If bit 5 of the 1st byte is 0:

15th byte - Rx level (low - Hex)

16th byte - Rx level (high - Hex)

If bit 4 of the 1st byte is 1:

15th byte - Measure of error rate (low - Hex)

16th byte - Measure of error rate (high - Hex)

17th byte - Final modem rate

Bits 0 to 2: Final modem speed

$$\begin{pmatrix} \text{Bit0} \\ \text{Bit1} \\ \text{Bit2} \end{pmatrix} = \begin{pmatrix} 1 \\ 0 \\ 0 \end{pmatrix} : 2.4k \begin{pmatrix} 0 \\ 1 \\ 0 \end{pmatrix} : 4.8k \begin{pmatrix} 1 \\ 1 \\ 0 \end{pmatrix} : 7.2k \begin{pmatrix} 0 \\ 0 \\ 1 \end{pmatrix} : 9.6k \begin{pmatrix} 1 \\ 0 \\ 1 \end{pmatrix} : 12.0k \begin{pmatrix} 0 \\ 1 \\ 1 \end{pmatrix} : 14.4k$$

Bit 3: Not used

Bits 4 to 6: Final modem type

$$\begin{pmatrix} \text{Bit4} \\ \text{Bit5} \\ \text{Bit6} \end{pmatrix} = \begin{pmatrix} 1 \\ 0 \\ 0 \end{pmatrix} : V.27ter \begin{pmatrix} 0 \\ 1 \\ 0 \end{pmatrix} : V.29 \begin{pmatrix} 0 \\ 0 \\ 1 \end{pmatrix} : V.17 \begin{pmatrix} 1 \\ 0 \\ 1 \end{pmatrix} : V.17$$

*(Long)*      *(Short)*

Bit 7: Not used

18th to 20th byte - Not used

21st to 44th byte - Remote terminal's ID (RTI, TSI or CSI) (ASCII)

45th byte - Communication mode #1

Bits 0 - 1: Resolution used

$$\begin{pmatrix} \text{Bit0} \\ \text{Bit1} \end{pmatrix} = \begin{pmatrix} 1 \\ 0 \end{pmatrix} : \text{Standard} \quad \begin{pmatrix} 0 \\ 1 \end{pmatrix} : \text{Detail} \quad \begin{pmatrix} 1 \\ 1 \end{pmatrix} : \text{Fine}$$

Bit 2: Communication Protocol 0: G3, 1: G4

Bit 3: ECM 0: Off, 1: On

Bits 4 to 7: Communication mode used

$$\begin{pmatrix} \text{Bit4} \\ \text{Bit5} \\ \text{Bit6} \\ \text{Bit7} \end{pmatrix} = \begin{pmatrix} 0 \\ 0 \\ 0 \\ 0 \end{pmatrix} : \text{Normal} \quad \begin{pmatrix} 1 \\ 0 \\ 0 \\ 0 \end{pmatrix} : \text{Confidential} \quad \begin{pmatrix} 0 \\ 1 \\ 0 \\ 0 \end{pmatrix} : \text{Polling} \quad \begin{pmatrix} 1 \\ 1 \\ 0 \\ 0 \end{pmatrix} : \text{Transfer}$$

$$\begin{pmatrix} \text{Bit4} \\ \text{Bit5} \\ \text{Bit6} \\ \text{Bit7} \end{pmatrix} = \begin{pmatrix} 0 \\ 0 \\ 1 \\ 0 \end{pmatrix} : \text{Forwarding} \quad \begin{pmatrix} 1 \\ 0 \\ 1 \\ 0 \end{pmatrix} : \begin{matrix} \text{Automatic} \\ \text{Service Call} \end{matrix}$$

46th byte - Communication mode #2

Bit 0: Tx or Rx 0: Tx, 1: Rx

Bit 1: Reduction in Tx 0: Not reduced, 1: Reduced

Bit 2: Batch transmission 0: Not used, 1: Used

Bit 3: Send later transmission 0: Not used, 1: Used

Bit 4: Transmission from 0: ADF, 1: Memory

Bit 5: Not used

Bits 6 and 7: Network type used

$$\begin{pmatrix} \text{Bit6} \\ \text{Bit7} \end{pmatrix} = \begin{pmatrix} 1 \\ 0 \end{pmatrix} : \text{PSTN}, \quad \begin{pmatrix} 0 \\ 1 \end{pmatrix} : \text{ISDN}$$

47th byte - Not used

48th byte - Number of errors during communication (Hex)

49th to 52nd byte - 1st error code and page number where the error occurred

49th byte - Page number where the error occurred (low - Hex)

50th byte - Page number where the error occurred (high - Hex)

51th byte - Error code (low - BCD)

52th byte - Error code (high - BCD)

53th to 56th byte - 2nd error code and page number where the error occurred

57th to 60th byte - 3rd error code and page number where the error occurred

61st to 64th byte - 4th error code and page number where the error occurred

65th to 68th byte - 5th error code and page number where the error occurred

69th to 72nd byte - 6th error code and page number where the error occurred

73rd to 76th byte - 7th error code and page number where the error occurred

77th to 80th byte - 8th error code and page number where the error occurred

81st to 84th byte - 9th error code and page number where the error occurred

85th to 88th byte - 10th error code and page number where the error occurred

**49FB64 to 49FB77(H)** - SC codes NOT for automatic service call

If the fax unit receives an SC code from the copier engine other than programmed in these addresses, the fax unit sends an automatic service call report to the programmed service station.

Six SC codes have already been programmed at default, as shown in the table below. Four more SC codes can be programmed, if required (If an address contains FF(H), a code is not programmed in it).

Program an SC code in four-digit BCD format as shown in the example below.

**Example:** SC code '192'

Address (High) - 01(BCD)

Address (Low) - 92 (BCD)

**- Default settings -**

| High Address (H) | Data (BCD) | Low Address (L) | Data (BCD) | SC code           |
|------------------|------------|-----------------|------------|-------------------|
| 49FB64           | 01         | 49FB65          | 92         | 192               |
| 49FB66           | 01         | 49FB67          | 93         | 193               |
| 49FB68           | 03         | 49FB69          | 90         | 390               |
| 49FB6A           | 03         | 49FB6B          | 93         | 393               |
| 49FB6C           | 06         | 49FB6D          | 91         | 691               |
| 49FB6E           | 09         | 49FB6F          | 80         | 980               |
| 49FB70           | FF(H)      | 49FB71          | FF(H)      | Hot<br>Programmed |
| 49FB72           | FF(H)      | 49FB73          | FF(H)      |                   |
| 49FB74           | FF(H)      | 49FB75          | FF(H)      |                   |
| 49FB76           | FF(H)      | 49FB77          | FF(H)      |                   |

**70001E to 700025(H)** - Hard disk information

If the data in these addresses do not match the following values after installing an optional hard disk, format the hard disk and check these addresses again.

70001E(H) - 50(H)

70001F(H) - 00(H)

700020(H) - 00(H)

700021(H) - FF(H)

700022(H) - 00(H)

700023(H) - 50(H)

700024(H) - 00(H)

700025(H) - 80(H)

---

## 6. SPECIAL TOOLS AND LUBRICANTS

- Flash/SRAM data copy tool (P/N: H5159100 or A1939353)
- EPROM board (P/N:H5159500 or A1939351)

## **SECTION 5**

# **REMOVAL AND REPLACEMENT**

---

# 1. PRECAUTION

**▲ CAUTION**

**Before starting disassembly, be sure to print all message files in the SAF memory. Then, turn off the main switch and disconnect the power cord and telephone cable for safety.**

**Lithium Battery**

**The danger of explosion exists if a battery of this type is incorrectly replaced. Replace only with the same or an equivalent type recommended by the manufacturer. Discard used batteries in accordance with the manufacturer's instructions.**



## 2. NCU

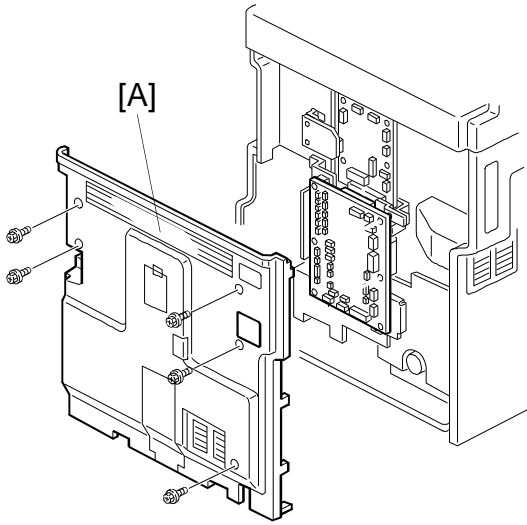

A194I500.wmf

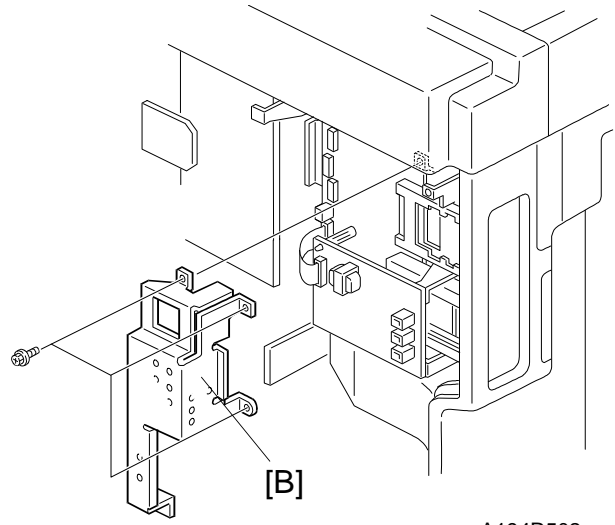

A194R502.wmf

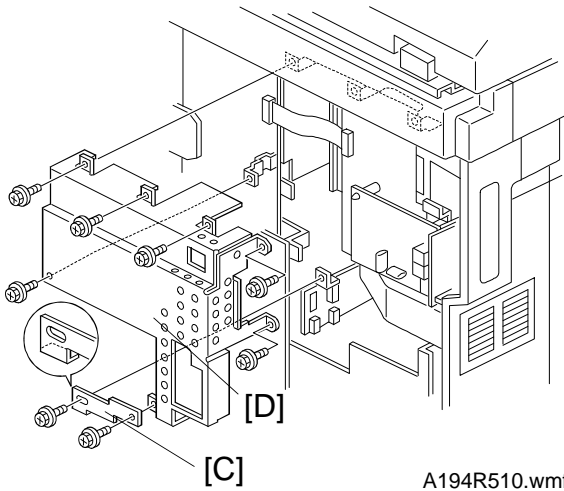

A194R510.wmf

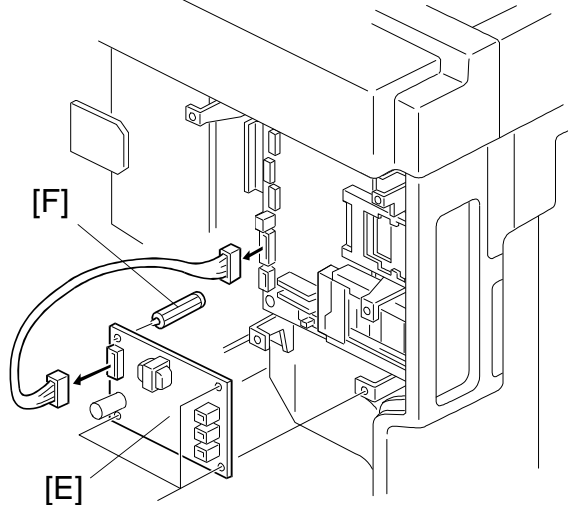

A194R503.wmf

1. Remove the rear cover [A].
2. **[US model]** Remove the bracket [B] (3 screws).  
**[Europe/Asia model]** Remove the brackets [C] (2 screws) and [D] (6 screws).
3. Remove the NCU [E] (3 screws, 1 harness - US; 2 harnesses - Eurpoe/Asia).
4. Remove the spacer shaft [F] from the old NCU, and install it on the new NCU.
5. Install the new NCU (3 screws, 1 harness; US - 2 harnesses), then replace the bracket [B] and the rear cover [A].

### 3. FCU

#### ⚠ CAUTION

If the machine has an optional Function Upgrade Card, change bit 7 of the System Switch 1E to "1" before performing the following procedure. This will prevent the data on the Function Upgrade Card from being erased.

Be sure to put the bit switch back to zero before step 18 below, otherwise the fax unit will not start up without the card installed. If the bit switch can not be changed, do not press "Yes" when the caution is displayed or data will be lost.

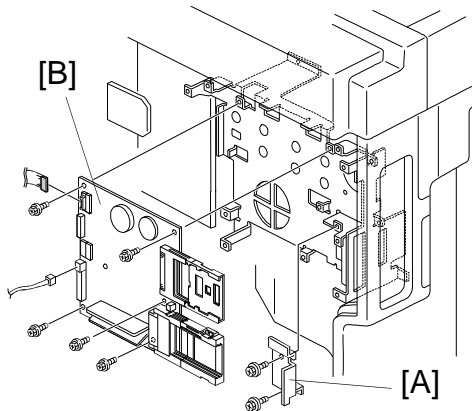

A194R501.wmf

1. Follow steps 1 through 3 in the NCU removal section above.
2. Disconnect the harnesses from CN500, CN505 and CN5110 on the FCU.
3. Remove the bracket [A] (2 screws) and the FCU [B] (5 screws).

**NOTE:** If optional units, such as IC cards or the Hard Disk, are installed on the old FCU, remove them all and install them on the new FCU.

4. Turn on the new FCU's battery switch (SW1) and install it.

**NOTE:** The FCU's battery switch (SW1) must be turned on at installation. If it isn't, all data programmed in the SRAM will be erased when the ac switch is turned off or a power failure occurs.

5. Replace the bracket [A] and the NCU.
6. Turn on the ac and main switches. When the caution message ("Functional Problem - SC1201") is displayed, press, "Yes."
7. Turn off the main and ac switches.
8. Turn off the machine's ac switch.

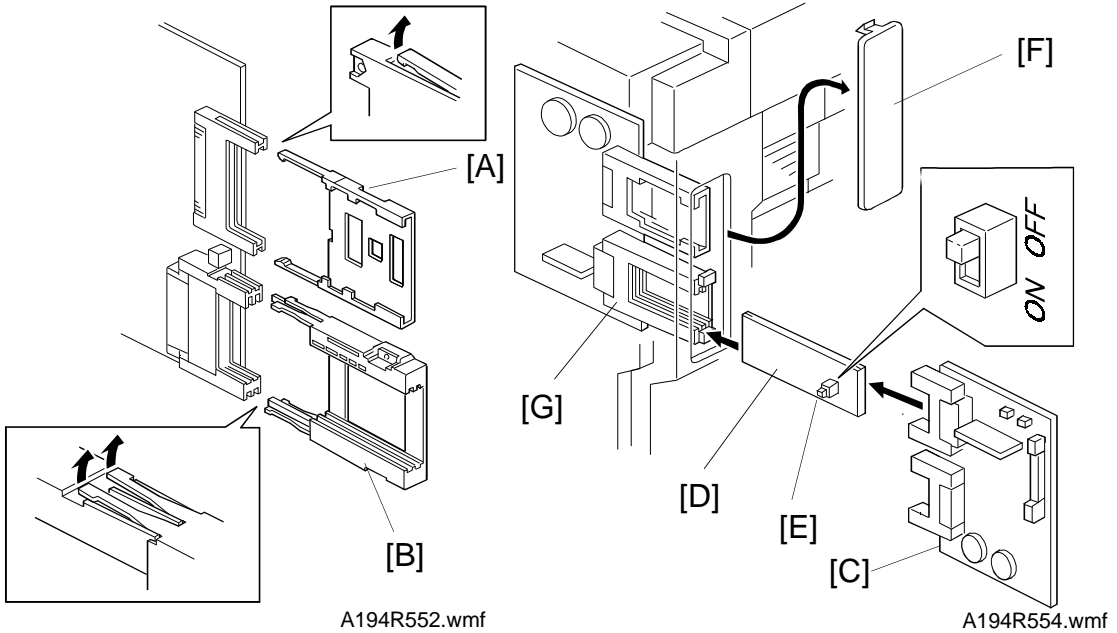

A194R552.wmf

A194R554.wmf

9. Remove the IC card guide rails ([A] and [B]) from the old FCU.
10. Connect the target FCU [C] to the data copy tool [D], and make sure that the switch [E] on the data copy tool [D] is off.
11. Remove the cover [F]. Insert the copy tool [D] in the lower left slot [G].
12. Turn on the machine's ac and main switches, then enter fax service mode.

13. Press

14. Press  then

If the software has been successfully uploaded, the display shows 'OK'.

Otherwise, the display shows 'NG'.

15. Exit the service mode.

16. Turn off the ac and main switches, then disconnect the tools.

**NOTE:** If the machine had a Function Upgrade Card before uploading the software, be sure to put the card back in the slot before switching on.

17. Turn the machine back on.

18. Print the system parameter list to check if the previous settings have been successfully recovered.

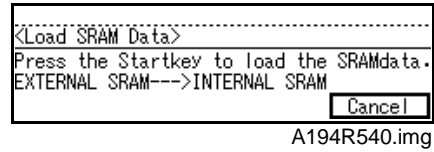
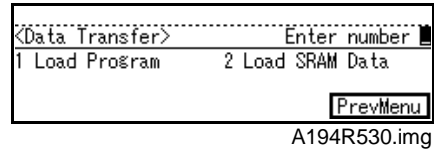

**SECTION 6**  
**TROUBLESHOOTING**

# 1. ERROR CODES

If an error code occurs, retry the communication. If the same problem occurs, try to fix the problem as suggested below. Note that error codes 4-00, 01, 02, and 10 only appear in the error code display and on the service report.

| Code | Meaning   | Suggested Cause/Action   |
|------|---|--|
| 0-00 | DIS/NSF not detected within 40 s of Start being pressed | Check the line connection.<br>Check the NCU - FCU connectors.<br>The machine at the other end may be incompatible.<br>Replace the NCU or FCU.<br>Check for DIS/NSF with an oscilloscope.<br>If the rx signal is weak, there may be a bad line.   |
| 0-01 | DCN received unexpectedly                               | The other party is out of paper or has a jammed printer.<br>The other party pressed Stop during communication.   |
| 0-03 | Incompatible modem at the other end                     | The other terminal is incompatible.  |
| 0-04 | CFR or FTT not received after modem training            | Check the line connection.<br>Check the NCU - FCU connectors.<br>Try changing the tx level and/or cable equalizer settings.<br>Replace the FCU or NCU.<br>The other terminal may be faulty; try sending to another machine.<br>If the rx signal is weak or defective, there may be a bad line.<br><b>Cross reference</b><br>Tx level - NCU Parameter 01 (PSTN)<br>Cable equalizer - G3 Switch 07 (PSTN)<br>Dedicated Tx parameters - Section 4 |
| 0-05 | Unsuccessful after modem training at 2400 bps           | Check the line connection.<br>Check the NCU - FCU connectors.<br>Try adjusting the tx level and/or cable equalizer.<br>Replace the FCU or NCU.<br>Check for line problems.<br><b>Cross reference</b><br>See error code 0-04.   |
| 0-06 | The other terminal did not reply to DCS                 | Check the line connection.<br>Check the FCU - NCU connectors.<br>Try adjusting the tx level and/or cable equalizer settings.<br>Replace the NCU or FCU.<br>The other end may be defective or incompatible; try sending to another machine.<br>Check for line problems.<br><b>Cross reference</b><br>See error code 0-04.   |

| Code | Meaning  | Suggested Cause/Action   |
|------|--|--|
| 0-07 | No post-message response from the other end after a page was sent                        | <p>Check the line connection.<br/>           Check the FCU - NCU connectors.<br/>           Replace the NCU or FCU.<br/>           The other end may have jammed or run out of paper.<br/>           The other end user may have disconnected the call.<br/>           Check for a bad line.<br/>           The other end may be defective; try sending to another machine.</p>  |
| 0-08 | The other end sent RTN or PIN after receiving a page, because there were too many errors | <p>Check the line connection.<br/>           Check the FCU - NCU connectors.<br/>           Replace the NCU or FCU.<br/>           The other end may have jammed, or run out of paper or memory space.<br/>           Try adjusting the tx level and/or cable equalizer settings.<br/>           The other end may have a defective modem/NCU/FCU; try sending to another machine.<br/>           Check for line problems and noise.<br/> <b>Cross reference</b><br/>           Tx level - NCU Parameter 01 (PSTN)<br/>           Cable equalizer - G3 Switch 07 (PSTN)<br/>           Dedicated Tx parameters - Section 4</p> |
| 0-14 | Non-standard post message response code received   | <p>Check the FCU - NCU connectors.<br/>           Incompatible or defective remote terminal; try sending to another machine.<br/>           Noisy line: resend.<br/>           Try adjusting the tx level and/or cable equalizer settings.<br/>           Replace the NCU or FCU.<br/> <b>Cross reference</b><br/>           See error code 0-08.</p>  |
| 0-15 | The other end does not have the confidential or transfer function                        | <p>The other terminal does not have the confidential rx or transfer function, or the other terminal's memory is full.</p>  |
| 0-16 | CFR or FTT not detected after modem training in confidential or transfer mode            | <p>Check the line connection.<br/>           Check the FCU - NCU connectors.<br/>           Replace the NCU or FCU.<br/>           Try adjusting the tx level and/or cable equalizer settings.<br/>           The other end may have disconnected, or it may be defective; try calling another machine.<br/>           If the rx signal level is too low, there may be a line problem.<br/> <b>Cross reference</b><br/>           See error code 0-08.</p>   |
| 0-17 | Communication was interrupted by pressing the Stop key.                                  | <p>If the Stop key was not pressed and this error keeps occurring, replace the operation panel or OPU.</p>   |

| Code | Meaning   | Suggested Cause/Action   |
|------|---|--|
| 0-20 | Facsimile data not received within 6 s of retraining  | Check the line connection.<br>Check the FCU - NCU connectors.<br>Replace the NCU or FCU.<br>Check for line problems.<br>Try calling another fax machine.<br>Try adjusting the reconstruction time for the first line and/or rx cable equalizer setting.<br><b>Cross reference</b><br>Reconstruction time - G3 Switch 0A, bit 6<br>Rx cable equalizer - G3 Switch 07 (PSTN)   |
| 0-21 | EOL signal (end-of-line) from the other end not received within 5 s of the previous EOL signal                      | Check the connections between the FCU, NCU, & line.<br>Check for line noise or other line problems.<br>Replace the NCU or FCU.<br>The remote machine may be defective or may have disconnected.<br><b>Cross reference</b><br>Maximum interval between EOLs and ECM frames - G3 Bit Switch 0A, bit 4  |
| 0-22 | The signal from the other end was interrupted for more than the acceptable modem carrier drop time (default: 0.2 s) | Check the line connection.<br>Check the FCU - NCU connectors.<br>Replace the NCU or FCU.<br>Defective remote terminal.<br>Check for line noise or other line problems.<br>Try adjusting the acceptable modem carrier drop time.<br><b>Cross reference</b><br>Acceptable modem carrier drop time - G3 Switch 0A, bits 0 and 1   |
| 0-23 | Too many errors during reception  | Check the line connection.<br>Check the FCU - NCU connectors.<br>Replace the NCU, FCU or FCU.<br>Defective remote terminal.<br>Check for line noise or other line problems.<br>Try asking the other end to adjust their tx level.<br>Try adjusting the rx cable equalizer setting and/or rx error criteria.<br><b>Cross reference</b><br>Rx cable equalizer - G3 Switch 07 (PSTN)<br>Rx error criteria - Communication Switch 02, bits 0 and 1 |
| 0-24 | Printer failure occurred while the memory was full during non-ECM reception; negative response returned             | There is no memory space available, or substitute reception is disabled.<br>Try asking the user to add optional extra memory.  |
| 0-30 | The other terminal did not reply to NSS(A) in AI short protocol mode  | Check the line connection.<br>Check the FCU - NCU connectors.<br>Try adjusting the tx level and/or cable equalizer settings.<br>The other terminal may not be compatible.<br><b>Cross reference</b><br>Dedicated tx parameters - Section 4   |



| <b>Code</b> | <b>Meaning</b>  | <b>Suggested Cause/Action</b>   |
|-------------|---|---|
| 0-52        | Polarity changed during communication   | Check the line connection.<br>Retry communication.  |
| 2-10        | The modem cannot enter tx mode  | Replace the FCU.  |
| 2-11        | Only one V.21 connection flag was received  | Change the FCU.   |
| 2-12        | Modem clock irregularity  | Replace the FCU.  |
| 2-20        | Abnormal coding/decoding (cpu not ready)  | Replace the FCU.  |
| 2-50        | The machine reset itself  | If this is frequent, replace the FCU.   |
| 3-00        | G4 interface board reset  | Replace the G4 interface board or FCU.  |
| 3-10        | Disconnection during ISDN G3 communication  | Check the other terminal and the ISDN line.<br>The other terminal may have dialed a wrong number.                                 |
| 3-11        | Disconnection during ISDN G4 communication  | Check the other terminal and the ISDN line.   |
| 3-20        | A CSA signal was received during ISDN G4 communication  | The operator at the other terminal may have interrupted the communication.  |
| 3-21        | A CSA was sent during ISDN G4 communication, because the Stop key was pressed   | The local operator has interrupted the communication.   |
| 3-30        | Mismatched specifications (rx capability)   | Check the receive capabilities requested from the other terminal.   |
| 4-00        | One page took longer than 8 minutes to transmit   | Check for a bad line.<br>Try the communication at a lower resolution, or without halftone.<br>Change the FCU.                     |
| 4-01        | Line current was cut  | Check the line connector.<br>Check the connection between FCU and NCU.<br>Check for line problems.<br>Replace the FCU or the NCU. |
| 4-02        | The other end cut the received page as it was longer than the maximum limit.  | Split the page into smaller pieces, or ask the other end to change their maximum receive length setting, then resend.             |
| 4-10        | Communication failed because of ID Code mismatch (Closed Network) or Tel. No./CSI mismatch (Protection against Wrong Connections) | Get the ID Codes the same and/or the CSIs programmed correctly, then resend.<br>The machine at the other end may be defective.    |
| 5-00        | Data reconstruction not possible  | Replace the FCU.  |
| 5-10        | DCR timer expired   | Replace the FCU.  |
| 5-20        | Storage impossible because of a lack of memory  | Temporary memory shortage.<br><br>Test the SAF memory.  |
| 5-21        | Memory overflow   | Replace the FCU or optional IC card.  |

| <b>Code</b> | <b>Meaning</b>   | <b>Suggested Cause/Action</b>   |
|-------------|--|---|
| 5-22        | Mode table overflow after the second page of a scanned document                                    | Wait for the messages which are currently in the memory to be sent or delete some files from memory.  |
| 5-23        | Print data error when printing a substitute rx or confidential rx message                          | Test the SAF memory.<br>Ask the other end to resend the message.<br>Replace the FCU or IC memory card.  |
| 5-24        | Memory overflow after the second page of a scanned document  | Try using a lower resolution setting.<br>Wait for the messages which are currently in the memory to be sent or delete some files from memory.   |
| 5-25        | SAF file access error  | Replace the FCU, the IC memory card, or the hard disk.  |
| 5-30        | Mode table for the first page to be printed was not effective                                      | Replace the FCU, the IC memory card, the function upgrade card, or the hard disk.   |
| 6-01        | G3 ECM - no V.21 signal was received   | Try adjusting the rx cable equalizer.<br>Replace the FCU or NCU.  |
| 6-02        | G3 ECM - EOR was received  |   |
| 6-03        | G3 ECM - non-standard V.21 code received   | The other terminal may be defective.  |
| 6-04        | G3 ECM - RTC not detected  | Check the line connection.<br>Check connections from the NCU to the FCU.<br>Check for a bad line or defective remote terminal.<br>Replace the FCU or NCU.   |
| 6-05        | G3 ECM - facsimile data frame not received within 18 s of CFR, but there was no line fail          | Check the line connection.<br>Check connections from the NCU to the FCU.<br>Check for a bad line or defective remote terminal.<br>Replace the FCU or NCU.<br>Try adjusting the rx cable equalizer<br><b>Cross reference</b><br>Rx cable equalizer - G3 Switch 07 (PSTN) |
| 6-06        | G3 ECM - coding/decoding error   | Defective FCU.<br>The other terminal may be defective.  |
| 6-08        | G3 ECM - PIP/PIN received in reply to PPS.NULL   | The other end pressed Stop during communication.<br>The other terminal may be defective.  |
| 6-09        | G3 ECM - ERR received  | Check for a noisy line.<br>Adjust the tx levels of the communicating machines.<br>See code 6-05.  |
| 6-10        | G3 ECM - error frames still received at the other end after all communication attempts at 2400 bps | Check for line noise.<br>Adjust the tx level (use NCU parameter 01 or the dedicated tx parameter for that address).<br>Check the line connection.<br>Defective remote terminal.   |
| 6-11        | G3 ECM - printing impossible because of a missing first line in the MMR coding                     | Check for problems in the printer mechanism.  |

| Code  | Meaning  | Suggested Cause/Action  |
|-------|--|---|
| 6-21  | V.21 flag detected during high speed modem communication | The other terminal may be defective or incompatible.  |
| 6-39  | V.21 signal not stopped within 6 s                       | Replace the FCU.  |
| 9-30  | HDD write error  | Turn the main and ac switches off and on, to mark defective sectors as bad and to initialize the hard disk. Initialize the hard disk interface (service mode 08-1). Check the cable connections. Format the hard disk (service mode 08-2). Replace the hard disk interface card. Replace the hard disk. |
| 9-31  | HDD control error  |   |
| 9-32  | HDD read error   |   |
| 9-33  | HDD fatal error  | Turn the main and ac switches off and on. Replace the hard disk.  |
| 9-40  | CRC error while receiveing a frame                       | Check and adjust the host PC's RS232C port settings. Check if a proper cable is used and is connected securely.   |
| 9-41  | Command 3rd try failed                                   |   |
| 9-42  | DCN received unexpectedly                                | Check if the application is working correctly. If the problem persists, replace the FCU.<br><br><b>Note:</b> The optional RS232C interface may not be available in some countries.  |
| 9-43  | Unexpected frame received                                |   |
| 9-44  | Response time over                                       |   |
| 9-45  | Frame transmission error                                 |   |
| 21-00 | BiCU communication error                                 | Check the cable connection between BiCU and FCU. Replace the BiCU or FCU.   |
| 21-01 | BiCU turned off  | Check if the LED (+5V supply) on the BiCU is lit or not. Check the cable connection between BiCU and FCU. Replace the BiCU or FCU.  |
| 21-02 | BiCU handshake error                                     | Check the cable connection between BiCU and FCU. Replace the BiCU or FCU.   |
| 22-00 | Original length exceeded the maximum scannable length    | Divide the original into a few pages. Check the resolution used for scanning. Lower the scan resolution if possible. Add optional page memory.  |
| 22-01 | Memory overflow while receiving                          | Wait for the files in the queue to be sent. Delete unnecessary files from memory. Transfer the substitute reception files to an another fax machine, if the machine's printer is busy or out of order. Add an optional SAF memory card or hard disk.  |

---

## 2. FAX SC CODES

When the FCU detects a Fax SC Code condition other than SC1201 and SC1701, it resets itself automatically (default setting). This initializes the FCU without erasing files in the SAF memory or resetting the switches.

**Note** For details on Fax SC Codes 1201 and 1701, refer to the following sections.

If bit 7 of System Switch 1F is changed to “1”, when the FCU detects a Fax SC Code condition, it displays the code on the display and stops working until the fax unit is initialized using one of the following methods:

- Press the “Facsimile” key and make sure the Facsimile LED is on. Then, hold down the “Speed Dial” key for more than 10 s.
- Turn off the main and ac switches and turn them back on.
- Remove the rear cover, and press SW2 on the FCU.

The fax unit cannot make automatic service calls in reaction to a Fax SC Code, because the fax unit cannot make fax communications in SC Code conditions.

### 2.1 SC1201

When the FCU detects an unrecoverable error in the SRAM, which requires a complete SRAM initialization, the fax unit displays this SC Code and stops. There is no way to recover from this error condition without a complete SRAM initialization (all the user and service programmed data will be erased).

The possible causes are:

- SRAM backup battery defect or SW1 on the FCU is at the “OFF” position
- SRAM or FCU physical defect
- IC card or Data Copy Tool connection was loose

### 2.2 SC1701

When the FCU detects a serious error in the print timing control signal, the fax unit displays this SC Code and stops.

To recover from this condition, turn the main and ac switches off and on, and check the physical connection between the FCU and BiCU.

If the problem still remains, replace the FCU or BiCU board.

## 2.3 FAX SC CODE TABLE

| SC Code | Description                           | Suggested Action  | When bit 7 of System Switch 1F = 0 | When bit 7 of System Switch 1F = 1 |
|---------|---------------------------------------|---|------------------------------------|------------------------------------|
| 1101    | Handshake error with BiCU at start-up | Initialize the fax unit. (See the previous page for the initialization procedure) | Automatic reset                    |                                    |
| 1102    |                                       |   |                                    |                                    |
| 1103    |                                       |   |                                    |                                    |
| 1111    | Command tx/rx error to/from the BiCU  | Refer to the previous page for details.   | SC Code display                    |                                    |
| 1112    | Base copier's engine was reset        |   |                                    |                                    |
| 1120    | Interface module error                |   |                                    |                                    |
| 1201    | Unrecoverable SRAM error              | Refer to the previous page for details.   | SC Code display                    |                                    |
| 1203    | Software error                        | Initialize the fax unit. (See the previous page for the initialization procedure) | Automatic reset                    | SC Code display                    |
| 1204    |                                       |   |                                    |                                    |
| 1205    |                                       |   |                                    |                                    |
| 1206    |                                       |   |                                    |                                    |
| 1251    |                                       |   |                                    |                                    |
| 1252    |                                       |   |                                    |                                    |
| 1253    |                                       |   |                                    |                                    |
| 1290    |                                       |   |                                    |                                    |
| 1301    |                                       |   |                                    |                                    |
| 1302    |                                       |   |                                    |                                    |
| 1303    |                                       |   |                                    |                                    |
| 1304    |                                       |   |                                    |                                    |
| 1305    |                                       |   |                                    |                                    |
| 1306    |                                       |   |                                    |                                    |
| 1307    |                                       |   |                                    |                                    |
| 1308    |                                       |   |                                    |                                    |
| 1401    | DCMMR timed out                       | Initialize the fax unit, or replace the FCU.                                      |                                    |                                    |
| 1402    | DMA4 table creation timed out         | Initialize the fax unit. (See the previous page for the initialization procedure) |                                    |                                    |
| 1501    | Error in Quick Dial data storage area |   |                                    |                                    |
| 1701    | FGATE monitor error                   | Refer to the previous page for details.   | SC Code display                    |                                    |



July 31st, 1996

# APPENDIX A

## Default Settings

The factory settings are quoted either in hexadecimal code (the actual contents of the RAM address) if there is a H after the value in the table, or in decimal (converted from the actual hex contents of the RAM address) if there is no H after the value.

Some RAMs must be stored using BCD; see the NCU Parameter definition table for details.

Note that the default settings may change after each country's PTT tests.

| Address      | 480401 | 480402 | 480403 | 480404 | 480405 |
|--------------|--------|--------|--------|--------|--------|
| France       | FFH    | FFH    | FFH    | 04H    | 80H    |
| Germany      | FFH    | FFH    | FFH    | 04H    | 98H    |
| UK           | FFH    | FFH    | FFH    | FFH    | FFH    |
| Italy        | FFH    | FFH    | FFH    | 04H    | 71H    |
| Austria      | FFH    | FFH    | FFH    | 05H    | 30H    |
| Belgium      | FFH    | FFH    | FFH    | 05H    | 20H    |
| Denmark      | FFH    | FFH    | FFH    | 05H    | 12H    |
| Finland      | FFH    | FFH    | FFH    | 05H    | 36H    |
| Ireland      | FFH    | FFH    | FFH    | 04H    | 50H    |
| Norway       | FFH    | FFH    | FFH    | 05H    | 12H    |
| Sweden       | FFH    | FFH    | FFH    | 05H    | 12H    |
| Switzerland  | FFH    | FFH    | FFH    | 06H    | 08H    |
| Portugal     | FFH    | FFH    | FFH    | 04H    | 60H    |
| Holland      | FFH    | FFH    | FFH    | 05H    | 63H    |
| Spain        | FFH    | FFH    | FFH    | 04H    | 90H    |
| Israel       | FFH    | FFH    | FFH    | 04H    | 98H    |
| USA          | FFH    | FFH    | FFH    | FFH    | FFH    |
| Asia         | FFH    | FFH    | FFH    | FFH    | FFH    |
| Hong Kong    | FFH    | FFH    | FFH    | FFH    | FFH    |
| South Africa | FFH    | FFH    | FFH    | FFH    | FFH    |
| Australia    | FFH    | FFH    | FFH    | 04H    | 50H    |
| New Zealand  | FFH    | FFH    | FFH    | FFH    | FFH    |
| Singapore    | FFH    | FFH    | FFH    | FFH    | FFH    |
| Malaysia     | FFH    | FFH    | FFH    | FFH    | FFH    |



| <b>Address</b> | <b>480406</b> | <b>480407</b> | <b>480408</b> | <b>480409</b> | <b>48040A</b> |
|----------------|---------------|---------------|---------------|---------------|---------------|
| France         | 04H           | 00H           | 75            | F4H           | 01H           |
| Germany        | 03H           | 70H           | 105           | E8H           | 03H           |
| UK             | FFH           | FFH           | FFH           | FFH           | FFH           |
| Italy          | 03H           | 91H           | 21H           | 21H           | 02H           |
| Austria        | 03H           | 70H           | 40            | F4H           | 01H           |
| Belgium        | 03H           | 00H           | 30            | 150           | 00H           |
| Denmark        | 03H           | 40H           | 65            | F4H           | 01H           |
| Finland        | 03H           | 15H           | 205           | F4H           | 01H           |
| Ireland        | 02H           | 00H           | 105           | F4H           | 1             |
| Norway         | 03H           | 40H           | 55            | E8H           | 03H           |
| Sweden         | 03H           | 40H           | 40            | 00H           | 01H           |
| Switzerland    | 03H           | 38H           | 40            | 21H           | 02H           |
| Portugal       | 02H           | 90H           | 105           | F4H           | 01H           |
| Holland        | 00H           | 76H           | 55            | EEH           | 02H           |
| Spain          | 03H           | 10H           | 75            | 80H           | 02H           |
| Israel         | 03H           | 40H           | 105           | E8H           | 03H           |
| USA            | FFH           | FFH           | FFH           | FFH           | FFH           |
| Asia           | FFH           | FFH           | FFH           | FFH           | FFH           |
| Hong Kong      | FFH           | FFH           | FFH           | FFH           | FFH           |
| South Africa   | FFH           | FFH           | FFH           | FFH           | FFH           |
| Australia      | 01H           | 30H           | 150           | 2CH           | 01H           |
| New Zealand    | FFH           | FFH           | FFH           | FFH           | FFH           |
| Singapore      | FFH           | FFH           | FFH           | FFH           | FFH           |
| Malaysia       | FFH           | FFH           | FFH           | FFH           | FFH           |

| <b>Address</b> | <b>48040B</b> | <b>48040C</b> | <b>48040D</b> | <b>48040E</b> | <b>48040F</b> |
|----------------|---------------|---------------|---------------|---------------|---------------|
| France         | 50            | 2             | 0             | 0             | FFH           |
| Germany        | 105           | 4             | 200           | 00H           | FFH           |
| UK             | FFH           | FFH           | 200           | 00H           | FFH           |
| Italy          | 30            | 50            | 200           | 00H           | FFH           |
| Austria        | 40            | 4             | 200           | 00H           | FFH           |
| Belgium        | 30            | 4             | 200           | 00H           | FFH           |
| Denmark        | 65            | 4             | 200           | 0             | FFH           |
| Finland        | 205           | 4             | 200           | 0             | FFH           |
| Ireland        | 105           | 4             | 200           | 0             | FFH           |
| Norway         | 55            | 4             | 200           | 0             | FFH           |
| Sweden         | 40            | 3             | 200           | 0             | FFH           |
| Switzerland    | 40            | 2             | 200           | 0             | 5             |
| Portugal       | 105           | 4             | 200           | 0             | FFH           |
| Holland        | 55            | 4             | 200           | 0             | FFH           |
| Spain          | 36            | 5             | 150           | 0             | FFH           |
| Israel         | 105           | 4             | 200           | 0             | FFH           |
| USA            | FFH           | FFH           | 100           | 0             | FFH           |
| Asia           | FFH           | FFH           | 100           | 0             | FFH           |
| Hong Kong      | FFH           | FFH           | 100           | 0             | FFH           |
| South Africa   | FFH           | FFH           | 100           | 0             | FFH           |
| Australia      | 100           | 8             | 150           | 0             | FFH           |
| New Zealand    | FFH           | FFH           | 100           | 0             | FFH           |
| Singapore      | FFH           | FFH           | 100           | 0             | FFH           |
| Malaysia       | FFH           | FFH           | 100           | 0             | FFH           |

| <b>Address</b> | <b>480410</b> | <b>480411</b> | <b>480412</b> | <b>480413</b> | <b>480414</b> |
|----------------|---------------|---------------|---------------|---------------|---------------|
| France         | FFH           | FFH           | FFH           | 04H           | 98H           |
| Germany        | FFH           | FFH           | FFH           | 05H           | 10H           |
| UK             | FFH           | FFH           | FFH           | 04H           | 30H           |
| Italy          | FFH           | FFH           | FFH           | 05H           | 29H           |
| Austria        | FFH           | FFH           | FFH           | 05H           | 12H           |
| Belgium        | FFH           | FFH           | FFH           | 04H           | 71H           |
| Denmark        | FFH           | FFH           | FFH           | 04H           | 60H           |
| Finland        | FFH           | FFH           | FFH           | FFH           | FFH           |
| Ireland        | FFH           | FFH           | FFH           | 04H           | 30H           |
| Norway         | FFH           | FFH           | FFH           | 05H           | 12H           |
| Sweden         | FFH           | FFH           | FFH           | 05H           | 12H           |
| Switzerland    | 50            | F4H           | 01H           | 06H           | 08H           |
| Portugal       | FFH           | FFH           | FFH           | FFH           | FFH           |
| Holland        | FFH           | FFH           | FFH           | 05H           | 63H           |
| Spain          | FFH           | FFH           | FFH           | 04H           | 60H           |
| Israel         | FFH           | FFH           | FFH           | 04H           | 98H           |
| USA            | FFH           | FFH           | FFH           | FFH           | FFH           |
| Asia           | FFH           | FFH           | FFH           | FFH           | FFH           |
| Hong Kong      | FFH           | FFH           | FFH           | FFH           | FFH           |
| South Africa   | FFH           | FFH           | FFH           | FFH           | FFH           |
| Australia      | FFH           | FFH           | FFH           | 04H           | 50H           |
| New Zealand    | FFH           | FFH           | FFH           | FFH           | FFH           |
| Singapore      | FFH           | FFH           | FFH           | FFH           | FFH           |
| Malaysia       | FFH           | FFH           | FFH           | FFH           | FFH           |

| <b>Address</b> | <b>480415</b> | <b>480416</b> | <b>480417</b> | <b>480418</b> | <b>480419</b> |
|----------------|---------------|---------------|---------------|---------------|---------------|
| France         | 03H           | 96H           | 09H           | 00H           | 03H           |
| Germany        | 03H           | 50H           | FFH           | FFH           | FFH           |
| UK             | 03H           | 60H           | FFH           | FFH           | FFH           |
| Italy          | 03H           | 29H           | 05H           | 12H           | 03H           |
| Austria        | 03H           | 80H           | FFH           | FFH           | FFH           |
| Belgium        | 04H           | 05H           | 05H           | 20H           | 03H           |
| Denmark        | 03H           | 90H           | 05H           | 12H           | 03H           |
| Finland        | FFH           | FFH           | FFH           | FFH           | FFH           |
| Ireland        | 03H           | 70H           | FFH           | FFH           | FFH           |
| Norway         | 03H           | 40H           | FFH           | FFH           | FFH           |
| Sweden         | 03H           | 40H           | 05H           | 12H           | 3             |
| Switzerland    | 03H           | 38H           | 06H           | 08H           | 03H           |
| Portugal       | FFH           | FFH           | FFH           | FFH           | FFH           |
| Holland        | 03H           | 20H           | 05H           | 63H           | 00H           |
| Spain          | 03H           | 80H           | FFH           | FFH           | FFH           |
| Israel         | 03H           | 70H           | 05H           | 63H           | 03H           |
| USA            | FFH           | FFH           | FFH           | FFH           | FFH           |
| Asia           | FFH           | FFH           | FFH           | FFH           | FFH           |
| Hong Kong      | FFH           | FFH           | FFH           | FFH           | FFH           |
| South Africa   | FFH           | FFH           | FFH           | FFH           | FFH           |
| Australia      | 03H           | 90H           | 04H           | 50H           | 03H           |
| New Zealand    | FFH           | FFH           | FFH           | FFH           | FFH           |
| Singapore      | FFH           | FFH           | FFH           | FFH           | FFH           |
| Malaysia       | FFH           | FFH           | FFH           | FFH           | FFH           |

| <b>Address</b> | <b>48041A</b> | <b>48041B</b> | <b>48041C</b> | <b>48041D</b> | <b>48041E</b> |
|----------------|---------------|---------------|---------------|---------------|---------------|
| France         | 00H           | 100           | 58H           | 02H           | 50            |
| Germany        | FFH           | FFH           | FFH           | FFH           | FFH           |
| UK             | FFH           | FFH           | FFH           | FFH           | FFH           |
| Italy          | 91H           | 100           | F9H           | 01H           | 9             |
| Austria        | FFH           | FFH           | FFH           | FFH           | FFH           |
| Belgium        | 00            | 30            | 150           | 0             | 30            |
| Denmark        | 40H           | 65            | F4H           | 01H           | 65            |
| Finland        | FFH           | FFH           | FFH           | FFH           | FFH           |
| Ireland        | FFH           | FFH           | FFH           | FFH           | FFH           |
| Norway         | FFH           | FFH           | FFH           | FFH           | FFH           |
| Sweden         | 40H           | 40            | 00            | 01H           | 40            |
| Switzerland    | 38H           | 40            | EFH           | 01H           | 40            |
| Portugal       | FFH           | FFH           | FFH           | FFH           | FFH           |
| Holland        | 76H           | 55            | EEH           | 02H           | 55            |
| Spain          | FFH           | FFH           | FFH           | FFH           | FFH           |
| Israel         | 70H           | 105           | E8H           | 03H           | 105           |
| USA            | FFH           | FFH           | FFH           | FFH           | FFH           |
| Asia           | FFH           | FFH           | FFH           | FFH           | FFH           |
| Hong Kong      | FFH           | FFH           | FFH           | FFH           | FFH           |
| South Africa   | FFH           | FFH           | FFH           | FFH           | FFH           |
| Australia      | 90H           | 150           | 2CH           | 01H           | 100           |
| New Zealand    | FFH           | FFH           | FFH           | FFH           | FFH           |
| Singapore      | FFH           | FFH           | FFH           | FFH           | FFH           |
| Malaysia       | FFH           | FFH           | FFH           | FFH           | FFH           |

| <b>Address</b> | <b>48041F</b> | <b>480420</b> | <b>480421</b> | <b>480422</b> | <b>480423</b> |
|----------------|---------------|---------------|---------------|---------------|---------------|
| France         | 02H           | 00H           | 00H           | FFH           | FFH           |
| Germany        | FFH           | 200           | 00H           | FFH           | FFH           |
| UK             | FFH           | 200           | 00H           | FFH           | FFH           |
| Italy          | 4             | 200           | 00H           | FFH           | FFH           |
| Austria        | FFH           | 200           | 00H           | FFH           | FFH           |
| Belgium        | 4             | 200           | 00H           | FFH           | FFH           |
| Denmark        | 4             | 200           | 00H           | FFH           | FFH           |
| Finland        | FFH           | 200           | 00H           | FFH           | FFH           |
| Ireland        | FFH           | 200           | 00H           | FFH           | FFH           |
| Norway         | FFH           | 200           | 00H           | FFH           | FFH           |
| Sweden         | 3             | 200           | 00H           | FFH           | FFH           |
| Switzerland    | 4             | 200           | 00H           | FFH           | FFH           |
| Portugal       | FFH           | 200           | 00H           | FFH           | FFH           |
| Holland        | 4             | 200           | 00H           | FFH           | FFH           |
| Spain          | FFH           | 150           | 00H           | FFH           | FFH           |
| Israel         | 4             | 200           | 00H           | FFH           | FFH           |
| USA            | FFH           | 200           | 00H           | FFH           | FFH           |
| Asia           | FFH           | 200           | 00H           | FFH           | FFH           |
| Hong Kong      | FFH           | 200           | 00H           | FFH           | FFH           |
| South Africa   | FFH           | 200           | 00H           | FFH           | FFH           |
| Australia      | 1             | 150           | 00H           | FFH           | FFH           |
| New Zealand    | FFH           | 200           | 00H           | FFH           | FFH           |
| Singapore      | FFH           | 200           | 00H           | FFH           | FFH           |
| Malaysia       | FFH           | 200           | 00H           | FFH           | FFH           |

| <b>Address</b> | <b>480424</b> | <b>480425</b> | <b>480426</b> | <b>480427</b> | <b>480428</b> |
|----------------|---------------|---------------|---------------|---------------|---------------|
| France         | FFH           | FFH           | FFH           | FFH           | FFH           |
| Germany        | FFH           | FFH           | FFH           | FFH           | FFH           |
| UK             | FFH           | FFH           | FFH           | FFH           | FFH           |
| Italy          | FFH           | FFH           | 06H           | 00            | 01H           |
| Austria        | FFH           | FFH           | 05H           | 12H           | 03H           |
| Belgium        | FFH           | FFH           | FFH           | FFH           | FFH           |
| Denmark        | FFH           | FFH           | 04H           | 60H           | 03H           |
| Finland        | FFH           | FFH           | FFH           | FFH           | FFH           |
| Ireland        | FFH           | FFH           | FFH           | FFH           | FFH           |
| Norway         | FFH           | FFH           | FFH           | FFH           | FFH           |
| Sweden         | FFH           | FFH           | FFH           | FFH           | FFH           |
| Switzerland    | FFH           | FFH           | 06H           | 08H           | 03H           |
| Portugal       | FFH           | FFH           | FFH           | FFH           | FFH           |
| Holland        | FFH           | FFH           | FFH           | FFH           | FFH           |
| Spain          | FFH           | FFH           | FFH           | FFH           | FFH           |
| Israel         | FFH           | FFH           | 05H           | 63H           | 03H           |
| USA            | FFH           | FFH           | FFH           | FFH           | FFH           |
| Asia           | FFH           | FFH           | FFH           | FFH           | FFH           |
| Hong Kong      | FFH           | FFH           | FFH           | FFH           | FFH           |
| South Africa   | FFH           | FFH           | FFH           | FFH           | FFH           |
| Australia      | FFH           | FFH           | 04H           | 50H           | 03H           |
| New Zealand    | FFH           | FFH           | FFH           | FFH           | FFH           |
| Singapore      | FFH           | FFH           | FFH           | FFH           | FFH           |
| Malaysia       | FFH           | FFH           | FFH           | FFH           | FFH           |

| <b>Address</b> | <b>480429</b> | <b>48042A</b> | <b>48042B</b> | <b>48042C</b> | <b>48042D</b> |
|----------------|---------------|---------------|---------------|---------------|---------------|
| France         | FFH           | 25            | 25            | FFH           | FFH           |
| Germany        | FFH           | 12            | 12            | 24            | 24            |
| UK             | FFH           | 19            | 19            | 20            | 17            |
| Italy          | 00H           | 15            | 15            | FFH           | FFH           |
| Austria        | 80H           | 10            | 10            | 15            | 15            |
| Belgium        | FFH           | 25            | 25            | 8             | 8             |
| Denmark        | 90H           | 12            | 12            | 8             | 23            |
| Finland        | FFH           | FFH           | FFH           | FFH           | 37            |
| Ireland        | FFH           | 25            | 25            | 27            | 37            |
| Norway         | FFH           | 10            | 0             | 25            | 0             |
| Sweden         | FFH           | 12            | 12            | 12            | 37            |
| Switzerland    | 38H           | 24            | 30            | 15            | 22            |
| Portugal       | FFH           | FFH           | FFH           | FFH           | FFH           |
| Holland        | FFH           | 12            | 12            | 25            | 25            |
| Spain          | FFH           | 8             | 8             | FFH           | FFH           |
| Israel         | 70H           | 12            | 12            | 24            | 24            |
| USA            | FFH           | FFH           | FFH           | FFH           | FFH           |
| Asia           | FFH           | FFH           | FFH           | FFH           | FFH           |
| Hong Kong      | FFH           | FFH           | FFH           | FFH           | FFH           |
| South Africa   | FFH           | FFH           | FFH           | FFH           | FFH           |
| Australia      | 90H           | 12            | 12            | 25            | 25            |
| New Zealand    | FFH           | FFH           | FFH           | FFH           | FFH           |
| Singapore      | FFH           | FFH           | FFH           | FFH           | FFH           |
| Malaysia       | FFH           | FFH           | FFH           | FFH           | FFH           |

| <b>Address</b> | <b>48042E</b> | <b>48042F</b> | <b>480430</b> | <b>480431</b> | <b>480432</b> |
|----------------|---------------|---------------|---------------|---------------|---------------|
| France         | FFH           | FFH           | FFH           | FFH           | FFH           |
| Germany        | 7             | 24            | FFH           | FFH           | FFH           |
| UK             | 11            | 26            | FFH           | FFH           | 100           |
| Italy          | FFH           | FFH           | FFH           | FFH           | FFH           |
| Austria        | 20            | 20            | FFH           | FFH           | FFH           |
| Belgium        | FFH           | FFH           | FFH           | FFH           | FFH           |
| Denmark        | FFH           | FFH           | FFH           | FFH           | FFH           |
| Finland        | FFH           | FFH           | FFH           | FFH           | FFH           |
| Ireland        | 18            | 18            | FFH           | FFH           | 35            |
| Norway         | FFH           | FFH           | FFH           | FFH           | FFH           |
| Sweden         | FFH           | FFH           | FFH           | FFH           | FFH           |
| Switzerland    | 11            | 11            | 8             | 30            | FFH           |
| Portugal       | FFH           | FFH           | FFH           | FFH           | FFH           |
| Holland        | FFH           | FFH           | FFH           | FFH           | FFH           |
| Spain          | FFH           | FFH           | FFH           | FFH           | FFH           |
| Israel         | FFH           | FFH           | FFH           | FFH           | FFH           |
| USA            | FFH           | FFH           | FFH           | FFH           | FFH           |
| Asia           | FFH           | FFH           | FFH           | FFH           | FFH           |
| Hong Kong      | FFH           | FFH           | FFH           | FFH           | FFH           |
| South Africa   | FFH           | FFH           | FFH           | FFH           | FFH           |
| Australia      | FFH           | FFH           | FFH           | FFH           | FFH           |
| New Zealand    | FFH           | FFH           | FFH           | FFH           | FFH           |
| Singapore      | FFH           | FFH           | FFH           | FFH           | FFH           |
| Malaysia       | FFH           | FFH           | FFH           | FFH           | FFH           |

| <b>Address</b> | <b>480433</b> | <b>480434</b> | <b>480435</b> | <b>480436</b> | <b>480437</b> |
|----------------|---------------|---------------|---------------|---------------|---------------|
| France         | 42H           | 04H           | 74H           | 04H           | 06H           |
| Germany        | 31H           | FFH           | FFH           | FFH           | FFH           |
| UK             | 42H           | FFH           | FFH           | FFH           | FFH           |
| Italy          | 40H           | FFH           | FFH           | FFH           | FFH           |
| Austria        | 41H           | FFH           | FFH           | FFH           | FFH           |
| Belgium        | 43H           | 11H           | 60H           | 11H           | 10H           |
| Denmark        | 42H           | FFH           | FFH           | FFH           | FFH           |
| Finland        | FFH           | FFH           | FFH           | FFH           | FFH           |
| Ireland        | 43H           | FFH           | FFH           | FFH           | FFH           |
| Norway         | 40H           | FFH           | FFH           | FFH           | FFH           |
| Sweden         | 43H           | FFH           | FFH           | FFH           | FFH           |
| Switzerland    | 51H           | FFH           | FFH           | FFH           | FFH           |
| Portugal       | FFH           | FFH           | FFH           | FFH           | FFH           |
| Holland        | 41H           | 05H           | 63H           | 00H           | 76H           |
| Spain          | 41H           | 06H           | 20H           | 05H           | 80H           |
| Israel         | 41H           | FFH           | FFH           | FFH           | FFH           |
| USA            | FFH           | FFH           | FFH           | FFH           | FFH           |
| Asia           | FFH           | FFH           | FFH           | FFH           | FFH           |
| Hong Kong      | FFH           | FFH           | FFH           | FFH           | FFH           |
| South Africa   | FFH           | FFH           | FFH           | FFH           | FFH           |
| Australia      | 41H           | FFH           | FFH           | FFH           | FFH           |
| New Zealand    | FFH           | FFH           | FFH           | FFH           | FFH           |
| Singapore      | FFH           | FFH           | FFH           | FFH           | FFH           |
| Malaysia       | FFH           | FFH           | FFH           | FFH           | FFH           |

| <b>Address</b> | <b>480438</b> | <b>480439</b> | <b>48043A</b> | <b>48043B</b> | <b>48043C</b> |
|----------------|---------------|---------------|---------------|---------------|---------------|
| France         | 75            | 58H           | 2             | 75            | 2             |
| Germany        | FFH           | FFH           | FFH           | FFH           | FFH           |
| UK             | FFH           | FFH           | FFH           | FFH           | FFH           |
| Italy          | FFH           | FFH           | FFH           | FFH           | FFH           |
| Austria        | FFH           | FFH           | FFH           | FFH           | FFH           |
| Belgium        | 41H           | E8H           | 03H           | 17            | 33            |
| Denmark        | FFH           | FFH           | FFH           | FFH           | FFH           |
| Finland        | FFH           | FFH           | FFH           | FFH           | FFH           |
| Ireland        | FFH           | FFH           | FFH           | FFH           | FFH           |
| Norway         | FFH           | FFH           | FFH           | FFH           | FFH           |
| Sweden         | FFH           | FFH           | FFH           | FFH           | FFH           |
| Switzerland    | FFH           | FFH           | FFH           | FFH           | FFH           |
| Portugal       | FFH           | FFH           | FFH           | FFH           | FFH           |
| Holland        | 55            | EEH           | 02H           | 55            | 4             |
| Spain          | 75            | 80H           | 02H           | 36            | 5             |
| Israel         | FFH           | FFH           | FFH           | FFH           | FFH           |
| USA            | FFH           | FFH           | FFH           | FFH           | FFH           |
| Asia           | FFH           | FFH           | FFH           | FFH           | FFH           |
| Hong Kong      | FFH           | FFH           | FFH           | FFH           | FFH           |
| South Africa   | FFH           | FFH           | FFH           | FFH           | FFH           |
| Australia      | FFH           | FFH           | FFH           | FFH           | FFH           |
| New Zealand    | FFH           | FFH           | FFH           | FFH           | FFH           |
| Singapore      | FFH           | FFH           | FFH           | FFH           | FFH           |
| Malaysia       | FFH           | FFH           | FFH           | FFH           | FFH           |

| <b>Address</b> | <b>48043D</b> | <b>48043E</b> | <b>48043F</b> | <b>480440</b> | <b>480441</b> |
|----------------|---------------|---------------|---------------|---------------|---------------|
| France         | 0             | 0             | FFH           | FFH           | FFH           |
| Germany        | 00H           | 00H           | FFH           | FFH           | FFH           |
| UK             | 00H           | 00H           | FFH           | FFH           | FFH           |
| Italy          | 00H           | 00H           | FFH           | FFH           | FFH           |
| Austria        | 00H           | 00H           | FFH           | FFH           | FFH           |
| Belgium        | 00H           | 00H           | FFH           | FFH           | FFH           |
| Denmark        | 00H           | 00H           | FFH           | FFH           | FFH           |
| Finland        | 00H           | 00H           | FFH           | FFH           | FFH           |
| Ireland        | 00H           | 00H           | FFH           | FFH           | FFH           |
| Norway         | 00H           | 00H           | FFH           | FFH           | FFH           |
| Sweden         | 00H           | 00H           | 05H           | 12H           | 03H           |
| Switzerland    | 00H           | 00H           | FFH           | FFH           | FFH           |
| Portugal       | 00H           | 00H           | FFH           | FFH           | FFH           |
| Holland        | 00H           | 00H           | FFH           | FFH           | FFH           |
| Spain          | 150           | 0             | FFH           | FFH           | FFH           |
| Israel         | 00H           | 00H           | FFH           | FFH           | FFH           |
| USA            | 00H           | 00H           | FFH           | FFH           | FFH           |
| Asia           | 00H           | 00H           | FFH           | FFH           | FFH           |
| Hong Kong      | 00H           | 00H           | FFH           | FFH           | FFH           |
| South Africa   | 00H           | 00H           | FFH           | FFH           | FFH           |
| Australia      | 00H           | 00H           | FFH           | FFH           | FFH           |
| New Zealand    | 00H           | 00H           | FFH           | FFH           | FFH           |
| Singapore      | 00H           | 00H           | FFH           | FFH           | FFH           |
| Malaysia       | 00H           | 00H           | FFH           | FFH           | FFH           |

| <b>Address</b> | <b>480442</b> | <b>480443</b> | <b>480444</b> | <b>480445</b> | <b>480446</b> |
|----------------|---------------|---------------|---------------|---------------|---------------|
| France         | FFH           | FFH           | FFH           | FFH           | FFH           |
| Germany        | FFH           | FFH           | FFH           | FFH           | FFH           |
| UK             | FFH           | FFH           | FFH           | FFH           | FFH           |
| Italy          | FFH           | FFH           | FFH           | FFH           | FFH           |
| Austria        | FFH           | FFH           | FFH           | FFH           | FFH           |
| Belgium        | FFH           | FFH           | FFH           | FFH           | FFH           |
| Denmark        | FFH           | FFH           | FFH           | FFH           | FFH           |
| Finland        | FFH           | FFH           | FFH           | FFH           | FFH           |
| Ireland        | FFH           | FFH           | FFH           | FFH           | FFH           |
| Norway         | FFH           | FFH           | FFH           | FFH           | FFH           |
| Sweden         | 40H           | 40            | 00H           | 01H           | 40            |
| Switzerland    | FFH           | FFH           | FFH           | FFH           | FFH           |
| Portugal       | FFH           | FFH           | FFH           | FFH           | FFH           |
| Holland        | FFH           | FFH           | FFH           | FFH           | FFH           |
| Spain          | FFH           | FFH           | FFH           | FFH           | FFH           |
| Israel         | FFH           | FFH           | FFH           | FFH           | FFH           |
| USA            | FFH           | FFH           | FFH           | FFH           | FFH           |
| Asia           | FFH           | FFH           | FFH           | FFH           | FFH           |
| Hong Kong      | FFH           | FFH           | FFH           | FFH           | FFH           |
| South Africa   | FFH           | FFH           | FFH           | FFH           | FFH           |
| Australia      | FFH           | FFH           | FFH           | FFH           | FFH           |
| New Zealand    | FFH           | FFH           | FFH           | FFH           | FFH           |
| Singapore      | FFH           | FFH           | FFH           | FFH           | FFH           |
| Malaysia       | FFH           | FFH           | FFH           | FFH           | FFH           |

| <b>Address</b> | <b>480447</b> | <b>480448</b> | <b>480449</b> | <b>48044A</b> | <b>48044B</b> |
|----------------|---------------|---------------|---------------|---------------|---------------|
| France         | FFH           | 0             | 0             | 67            | 65            |
| Germany        | FFH           | 00H           | 00H           | 50            | 60            |
| UK             | FFH           | 00H           | 00H           | 252           | 66            |
| Italy          | FFH           | 00H           | 00H           | 58            | 60            |
| Austria        | FFH           | 00H           | 00H           | 53            | 62            |
| Belgium        | FFH           | 00H           | 00H           | 61            | 67            |
| Denmark        | FFH           | 00H           | 00H           | 53            | 67            |
| Finland        | FFH           | 00H           | 00H           | 61            | 60            |
| Ireland        | FFH           | 00H           | 00H           | 255           | 67            |
| Norway         | FFH           | 00H           | 00H           | 61            | 59            |
| Sweden         | 3             | 200           | 0             | 100           | 60            |
| Switzerland    | FFH           | 00H           | 00H           | 60            | 60            |
| Portugal       | FFH           | 00H           | 00H           | 61            | 66            |
| Holland        | FFH           | 00H           | 00H           | 58            | 62            |
| Spain          | FFH           | 00H           | 00H           | 75            | 60            |
| Israel         | FFH           | 00H           | 00H           | 61            | 61            |
| USA            | FFH           | 00H           | 00H           | 77            | 62            |
| Asia           | FFH           | 00H           | 00H           | 61            | 66            |
| Hong Kong      | FFH           | 00H           | 00H           | 61            | 66            |
| South Africa   | FFH           | 00H           | 00H           | 61            | 66            |
| Australia      | FFH           | 00H           | 00H           | 255           | 68            |
| New Zealand    | FFH           | 00H           | 00H           | 61            | 66            |
| Singapore      | FFH           | 00H           | 00H           | 61            | 66            |
| Malaysia       | FFH           | 00H           | 00H           | 61            | 66            |

| <b>Address</b> | <b>48044C</b> | <b>48044D</b> | <b>48044E</b> | <b>48044F</b> | <b>480450</b> |
|----------------|---------------|---------------|---------------|---------------|---------------|
| France         | 35            | 50            | 40            | 0             | 70            |
| Germany        | 41            | 44            | 46            | 46            | 90            |
| UK             | 35            | 44            | 27            | 33            | 100           |
| Italy          | 40            | 44            | 40            | 150           | 70            |
| Austria        | 39            | 50            | 44            | 46            | 80            |
| Belgium        | 33            | 50            | 43            | 26            | 70            |
| Denmark        | 33            | 50            | 26            | 26            | 90            |
| Finland        | 42            | 50            | 40            | 60            | 70            |
| Ireland        | 33            | 50            | 30            | 33            | 70            |
| Norway         | 41            | 50            | 33            | 33            | 70            |
| Sweden         | 40            | 70            | 18            | 26            | 70            |
| Switzerland    | 40            | 60            | 26            | 00H           | 70            |
| Portugal       | 34            | 50            | 33            | 33            | 70            |
| Holland        | 40            | 42            | 33            | 33            | 70            |
| Spain          | 33            | 75            | 32            | 100           | 70            |
| Israel         | 39            | 50            | 46            | 101           | 90            |
| USA            | 40            | 74            | 46            | 101           | 100           |
| Asia           | 34            | 50            | 36            | 101           | 100           |
| Hong Kong      | 34            | 50            | 36            | 101           | 100           |
| South Africa   | 34            | 50            | 36            | 101           | 100           |
| Australia      | 32            | 70            | 36            | 101           | 100           |
| New Zealand    | 34            | 50            | 36            | 101           | 100           |
| Singapore      | 34            | 50            | 36            | 101           | 100           |
| Malaysia       | 34            | 50            | 36            | 101           | 100           |

| <b>Address</b> | <b>480451</b> | <b>480452</b> | <b>480453</b> | <b>480454</b> | <b>480455</b> |
|----------------|---------------|---------------|---------------|---------------|---------------|
| France         | 70            | 12            | 4             | 34            | 34            |
| Germany        | 90            | 14            | 6             | 34            | 34            |
| UK             | 100           | 18            | 4             | 34            | 34            |
| Italy          | 70            | 12            | 4             | 34            | 34            |
| Austria        | 80            | 7             | 4             | 34            | 34            |
| Belgium        | 70            | 12            | 4             | 34            | 34            |
| Denmark        | 90            | 18            | 4             | 34            | 34            |
| Finland        | 75            | 18            | 4             | 34            | 34            |
| Ireland        | 70            | 18            | 4             | 34            | 34            |
| Norway         | 70            | 18            | 4             | 34            | 34            |
| Sweden         | 70            | 18            | 4             | 34            | 34            |
| Switzerland    | 70            | 12            | 4             | 34            | 34            |
| Portugal       | 70            | 18            | 4             | 34            | 34            |
| Holland        | 70            | 18            | 4             | 34            | 34            |
| Spain          | 140           | 12            | 4             | 34            | 34            |
| Israel         | 90            | 12            | 4             | 34            | 34            |
| USA            | 100           | 14            | 4             | 34            | 34            |
| Asia           | 110           | 12            | 4             | 34            | 34            |
| Hong Kong      | 110           | 12            | 4             | 34            | 34            |
| South Africa   | 110           | 12            | 4             | 34            | 34            |
| Australia      | 110           | 20            | 4             | 34            | 34            |
| New Zealand    | 110           | 12            | 4             | 34            | 34            |
| Singapore      | 110           | 12            | 4             | 34            | 34            |
| Malaysia       | 110           | 12            | 4             | 34            | 34            |



| <b>Address</b> | <b>480459</b> | <b>48045A</b> | <b>48045B</b> | <b>48045C</b> | <b>48045D</b> |
|----------------|---------------|---------------|---------------|---------------|---------------|
| France         | 0             | 0             | FFH           | 19H           | FFH           |
| Germany        | 15            | 90            | FFH           | 00H           | FFH           |
| UK             | 15            | 90            | FFH           | 00H           | 50            |
| Italy          | 15            | 90            | FFH           | 00H           | FFH           |
| Austria        | 15            | 100           | FFH           | 00H           | FFH           |
| Belgium        | 100           | 90            | FFH           | 00H           | FFH           |
| Denmark        | 15            | 90            | F0H           | 09H           | FFH           |
| Finland        | 15            | 90            | F9H           | 90H           | 100           |
| Ireland        | 15            | 90            | FFH           | 16H           | FFH           |
| Norway         | 25            | 90            | FFH           | 00H           | FFH           |
| Sweden         | 15            | 90            | F0H           | 09H           | FFH           |
| Switzerland    | 15            | 90            | FFH           | 00H           | FFH           |
| Portugal       | 15            | 90            | FFH           | 00H           | FFH           |
| Holland        | 15            | 90            | FFH           | 00H           | FFH           |
| Spain          | 100           | 90            | FFH           | 07H           | FFH           |
| Israel         | 15            | 90            | FFH           | 00H           | FFH           |
| USA            | 00H           | 00H           | FFH           | FFH           | FFH           |
| Asia           | 00H           | 00H           | FFH           | FFH           | FFH           |
| Hong Kong      | 00H           | 00H           | FFH           | FFH           | FFH           |
| South Africa   | 00H           | 00H           | FFH           | FFH           | FFH           |
| Australia      | 00H           | 00H           | FFH           | FFH           | FFH           |
| New Zealand    | 00H           | 00H           | FFH           | FFH           | FFH           |
| Singapore      | 00H           | 00H           | FFH           | FFH           | FFH           |
| Malaysia       | 00H           | 00H           | FFH           | FFH           | FFH           |

| <b>Address</b> | <b>48045E</b> | <b>48045F</b> | <b>480465</b> | <b>480466</b> | <b>480472</b> |
|----------------|---------------|---------------|---------------|---------------|---------------|
| France         | 80H           | 10H           | FFH           | 16H           | 17            |
| Germany        | C0H           | 10H           | FFH           | FFH           | 17            |
| UK             | C0H           | 10H           | FFH           | FFH           | 20            |
| Italy          | D1H           | 10H           | FFH           | FFH           | 18            |
| Austria        | C0H           | 10H           | FFH           | FFH           | 13            |
| Belgium        | 44H           | 10H           | FFH           | FFH           | 21            |
| Denmark        | 40H           | 10H           | FFH           | FFH           | 33            |
| Finland        | 40H           | 10H           | FFH           | FFH           | 16            |
| Ireland        | 80H           | 10H           | FFH           | FFH           | 36            |
| Norway         | 40H           | 10H           | FFH           | FFH           | 16            |
| Sweden         | 40H           | 10H           | FFH           | FFH           | 17            |
| Switzerland    | 80H           | 10H           | FFH           | FFH           | 16            |
| Portugal       | 40H           | 10H           | FFH           | FFH           | 30            |
| Holland        | 00            | 10H           | FFH           | FFH           | 16            |
| Spain          | 80H           | 10H           | FFH           | FFH           | 25            |
| Israel         | C0H           | 10H           | FFH           | FFH           | 16            |
| USA            | C0H           | 10H           | FFH           | FFH           | 13            |
| Asia           | C0H           | 10H           | FFH           | FFH           | 17            |
| Hong Kong      | C0H           | 10H           | FFH           | FFH           | 17            |
| South Africa   | C0H           | 10H           | FFH           | FFH           | 17            |
| Australia      | C0H           | 10H           | FFH           | FFH           | 14            |
| New Zealand    | C0H           | 10H           | FFH           | FFH           | 17            |
| Singapore      | C0H           | 10H           | FFH           | FFH           | 17            |
| Malaysia       | C0H           | 10H           | FFH           | FFH           | 17            |

| <b>Address</b> | <b>480473</b> | <b>480474</b> | <b>480475</b> | <b>480476</b> | <b>480477</b> |
|----------------|---------------|---------------|---------------|---------------|---------------|
| France         | 23            | FFH           | 00H           | 2             | 15            |
| Germany        | 48            | FFH           | 00H           | 01H           | 10            |
| UK             | 84            | FFH           | 00H           | 1             | 10            |
| Italy          | 77            | FFH           | 00H           | 2             | 10            |
| Austria        | 54            | FFH           | 00H           | 1             | 9             |
| Belgium        | 72            | FFH           | 00H           | 2             | 5             |
| Denmark        | 50            | 16            | 24            | 1             | 10            |
| Finland        | 56            | FFH           | 00H           | 2             | 25            |
| Ireland        | 67            | FFH           | 00H           | 1             | 10            |
| Norway         | 56            | FFH           | 00H           | 1             | 10            |
| Sweden         | 51            | FFH           | 00H           | 1             | 5             |
| Switzerland    | 51            | FFH           | 00H           | 3             | 1             |
| Portugal       | 78            | 16            | 24            | 1             | 10            |
| Holland        | 52            | FFH           | 00H           | 2             | 15            |
| Spain          | 50            | FFH           | 00H           | 2             | 10            |
| Israel         | 83            | FFH           | 00H           | 2             | 5             |
| USA            | 83            | FFH           | 00H           | 1             | 10            |
| Asia           | 83            | FFH           | 00H           | 1             | 10            |
| Hong Kong      | 83            | FFH           | 00H           | 1             | 10            |
| South Africa   | 83            | FFH           | 00H           | 1             | 10            |
| Australia      | 83            | FFH           | 00H           | 3             | 10            |
| New Zealand    | 83            | FFH           | 00H           | 3             | 10            |
| Singapore      | 83            | FFH           | 00H           | 1             | 10            |
| Malaysia       | 83            | FFH           | 00H           | 1             | 10            |

| <b>Address</b> | <b>480478</b> | <b>480479</b> | <b>48047A</b> | <b>480481</b> | <b>480482</b> |
|----------------|---------------|---------------|---------------|---------------|---------------|
| France         | 5             | 04H           | 01H           | 25            | 00H           |
| Germany        | 10            | 90H           | 01H           | 25            | 00H           |
| UK             | 10            | 90H           | 01H           | 25            | 00H           |
| Italy          | 10            | 90H           | 01H           | 25            | 00H           |
| Austria        | 10            | 90H           | 01H           | 25            | 00H           |
| Belgium        | 10            | 90H           | 01H           | 25            | 00H           |
| Denmark        | 10            | 90H           | 01H           | 25            | 00H           |
| Finland        | 25            | 90H           | 01H           | 25            | 00H           |
| Ireland        | 10            | 90H           | 01H           | 25            | 00H           |
| Norway         | 10            | 90H           | 01H           | 25            | 00H           |
| Sweden         | 5             | 90H           | 01H           | 25            | 00H           |
| Switzerland    | 1             | 90H           | 01H           | 25            | 00H           |
| Portugal       | 10            | 90H           | 01H           | 25            | 00H           |
| Holland        | 15            | 90H           | 01H           | 25            | 00H           |
| Spain          | 10            | 2CH           | 01H           | 25            | 00H           |
| Israel         | 5             | 90H           | 01H           | 25            | 00H           |
| USA            | 10            | 90H           | 01H           | 25            | 00H           |
| Asia           | 10            | 90H           | 01H           | 25            | 00H           |
| Hong Kong      | 10            | 90H           | 01H           | 25            | 00H           |
| South Africa   | 10            | 90H           | 01H           | 25            | 00H           |
| Australia      | 10            | 90H           | 01H           | 25            | 00H           |
| New Zealand    | 10            | 90H           | 01H           | 25            | 00H           |
| Singapore      | 10            | 90H           | 01H           | 25            | 00H           |
| Malaysia       | 10            | 90H           | 01H           | 25            | 00H           |

| <b>Address</b> | <b>480483</b> | <b>480484</b> | <b>4804A1</b> | <b>4804A2</b> | <b>4804A3</b> |
|----------------|---------------|---------------|---------------|---------------|---------------|
| France         | 11H           | 24H           | 22H           | 00            | 20H           |
| Germany        | 11H           | 24H           | 22H           | 00            | 20H           |
| UK             | 11H           | 24H           | 22H           | 00            | 20H           |
| Italy          | 11H           | 24H           | 22H           | 00            | 20H           |
| Austria        | 11H           | 24H           | 22H           | 00            | 20H           |
| Belgium        | 11H           | 24H           | 22H           | 00            | 20H           |
| Denmark        | 11H           | 24H           | 22H           | 00            | 20H           |
| Finland        | 11H           | 24H           | 22H           | 00            | 20H           |
| Ireland        | 11H           | 24H           | 22H           | 00            | 20H           |
| Norway         | 11H           | 24H           | 22H           | 00            | 20H           |
| Sweden         | 11H           | 24H           | 22H           | 00            | 20H           |
| Switzerland    | 11H           | 24H           | 22H           | 00            | 20H           |
| Portugal       | 11H           | 24H           | 22H           | 00            | 20H           |
| Holland        | 11H           | 24H           | 22H           | 00            | 20H           |
| Spain          | 11H           | 24H           | 22H           | 00            | 20H           |
| Israel         | 11H           | 24H           | 22H           | 00            | 20H           |
| USA            | 31H           | 24H           | 22H           | 00            | 20H           |
| Asia           | 11H           | 24H           | 22H           | 00            | 20H           |
| Hong Kong      | 11H           | 24H           | 22H           | 00            | 20H           |
| South Africa   | 11H           | 24H           | 22H           | 00            | 20H           |
| Australia      | 11H           | 24H           | 22H           | 00            | 20H           |
| New Zealand    | 11H           | 24H           | 22H           | 00            | 20H           |
| Singapore      | 11H           | 24H           | 22H           | 00            | 20H           |
| Malaysia       | 11H           | 24H           | 22H           | 00            | 20H           |

| <b>Address</b> | <b>4804A4</b> | <b>4804A5</b> | <b>4804A6</b> | <b>4804A7</b> | <b>4804A8</b> |
|----------------|---------------|---------------|---------------|---------------|---------------|
| France         | 00H           | 30            | 12H           | 00H           | 10H           |
| Germany        | 00H           | 10            | 12H           | 00H           | 10H           |
| UK             | 00H           | 10            | 12H           | 00H           | 10H           |
| Italy          | 00H           | 10            | 12H           | 00H           | 10H           |
| Austria        | 00H           | 10            | 12H           | 00H           | 10H           |
| Belgium        | 00H           | 10            | 12H           | 00H           | 10H           |
| Denmark        | 00H           | 10            | 12H           | 00H           | 10H           |
| Finland        | 00H           | 10            | 12H           | 00H           | 10H           |
| Ireland        | 00H           | 10            | 12H           | 00H           | 10H           |
| Norway         | 00H           | 10            | 12H           | 00H           | 10H           |
| Sweden         | 00H           | 10            | 12H           | 00H           | 10H           |
| Switzerland    | 00H           | 10            | 12H           | 00H           | 10H           |
| Portugal       | 00H           | 10            | 12H           | 00H           | 10H           |
| Holland        | 00H           | 10            | 12H           | 00H           | 10H           |
| Spain          | 00H           | 10            | 12H           | 00H           | 10H           |
| Israel         | 00H           | 10            | 12H           | 00H           | 10H           |
| USA            | 00H           | 10            | 12H           | 00H           | 10H           |
| Asia           | 00H           | 10            | 12H           | 00H           | 10H           |
| Hong Kong      | 00H           | 10            | 12H           | 00H           | 10H           |
| South Africa   | 00H           | 10            | 12H           | 00H           | 10H           |
| Australia      | 00H           | 10            | 12H           | 00H           | 10H           |
| New Zealand    | 00H           | 10            | 12H           | 00H           | 10H           |
| Singapore      | 00H           | 10            | 12H           | 00H           | 10H           |
| Malaysia       | 00H           | 10            | 12H           | 00H           | 10H           |

| <b>Address</b> | <b>4804A9</b> | <b>4804AA</b> | <b>4804AB</b> | <b>4804AC</b> | <b>4804AD</b> |
|----------------|---------------|---------------|---------------|---------------|---------------|
| France         | 00H           | 10            | 19H           | 96H           | 32H           |
| Germany        | 00H           | 10            | 19H           | 96H           | 32H           |
| UK             | 00H           | 10            | 19H           | 96H           | 32H           |
| Italy          | 00H           | 10            | 19H           | 96H           | 32H           |
| Austria        | 00H           | 10            | 19H           | 96H           | 32H           |
| Belgium        | 00H           | 10            | 19H           | 96H           | 32H           |
| Denmark        | 00H           | 10            | 19H           | 96H           | 32H           |
| Finland        | 00H           | 10            | 19H           | 96H           | 32H           |
| Ireland        | 00H           | 10            | 19H           | 96H           | 32H           |
| Norway         | 00H           | 10            | 19H           | 96H           | 32H           |
| Sweden         | 00H           | 10            | 19H           | 96H           | 32H           |
| Switzerland    | 00H           | 10            | 19H           | 96H           | 32H           |
| Portugal       | 00H           | 10            | 19H           | 96H           | 32H           |
| Holland        | 00H           | 10            | 19H           | 96H           | 32H           |
| Spain          | 00H           | 10            | 19H           | 96H           | 32H           |
| Israel         | 00H           | 10            | 19H           | 96H           | 32H           |
| USA            | 00H           | 10            | 19H           | 96H           | 32H           |
| Asia           | 00H           | 10            | 19H           | 96H           | 32H           |
| Hong Kong      | 00H           | 10            | 19H           | 96H           | 32H           |
| South Africa   | 00H           | 10            | 19H           | 96H           | 32H           |
| Australia      | 00H           | 10            | 19H           | 96H           | 32H           |
| New Zealand    | 00H           | 10            | 19H           | 96H           | 32H           |
| Singapore      | 00H           | 10            | 19H           | 96H           | 32H           |
| Malaysia       | 00H           | 10            | 19H           | 96H           | 32H           |

| <b>Address</b> | <b>4804AF</b> | <b>4804B0</b> | <b>4804B1</b> | <b>4804B2</b> | <b>4804B3</b> |
|----------------|---------------|---------------|---------------|---------------|---------------|
| France         | 08H           | 80H           | 07H           | 20H           | 10            |
| Germany        | 08H           | 80H           | 07H           | 20H           | 10            |
| UK             | 08H           | 80H           | 07H           | 20H           | 10            |
| Italy          | 08H           | 80H           | 07H           | 20H           | 10            |
| Austria        | 08H           | 80H           | 07H           | 20H           | 10            |
| Belgium        | 08H           | 80H           | 07H           | 20H           | 10            |
| Denmark        | 08H           | 80H           | 07H           | 20H           | 10            |
| Finland        | 08H           | 80H           | 07H           | 20H           | 10            |
| Ireland        | 08H           | 80H           | 07H           | 20H           | 10            |
| Norway         | 08H           | 80H           | 07H           | 20H           | 10            |
| Sweden         | 08H           | 80H           | 07H           | 20H           | 10            |
| Switzerland    | 08H           | 80H           | 07H           | 20H           | 10            |
| Portugal       | 08H           | 80H           | 07H           | 20H           | 10            |
| Holland        | 08H           | 80H           | 07H           | 20H           | 10            |
| Spain          | 08H           | 80H           | 07H           | 20H           | 10            |
| Israel         | 08H           | 80H           | 07H           | 20H           | 10            |
| USA            | 08H           | 80H           | 07H           | 20H           | 10            |
| Asia           | 08H           | 80H           | 07H           | 20H           | 10            |
| Hong Kong      | 08H           | 80H           | 07H           | 20H           | 10            |
| South Africa   | 08H           | 80H           | 07H           | 20H           | 10            |
| Australia      | 08H           | 80H           | 07H           | 20H           | 10            |
| New Zealand    | 08H           | 80H           | 07H           | 20H           | 10            |
| Singapore      | 08H           | 80H           | 07H           | 20H           | 10            |
| Malaysia       | 08H           | 80H           | 07H           | 20H           | 10            |

| <b>Address</b> | <b>4804B4</b> | <b>4804B5</b> | <b>4804B6</b> | <b>4804B7</b> | <b>4804B8</b> |
|----------------|---------------|---------------|---------------|---------------|---------------|
| France         | 10            | 0             | 0             | 10            | 0             |
| Germany        | 6             | 3             | FEH           | 6             | 3             |
| UK             | 8             | 2             | 0             | 8             | 2             |
| Italy          | 6             | 0             | 0             | 6             | 0             |
| Austria        | 6             | 0             | 0             | 6             | 0             |
| Belgium        | 6             | 0             | 0             | 6             | 0             |
| Denmark        | 10            | 0             | 0             | 10            | 0             |
| Finland        | 10            | 0             | 0             | 10            | 0             |
| Ireland        | 10            | 0             | 0             | 10            | 0             |
| Norway         | 9             | 02H           | 0             | 9             | 02H           |
| Sweden         | 10            | 0             | 0             | 10            | 0             |
| Switzerland    | 5             | 1             | FFH           | 5             | 1             |
| Portugal       | 6             | 0             | 0             | 6             | 0             |
| Holland        | 7             | 0             | 0             | 7             | 0             |
| Spain          | 10            | 0             | 0             | 10            | 0             |
| Israel         | 6             | 0             | 0             | 6             | 0             |
| USA            | 9             | 0             | 0             | 9             | 0             |
| Asia           | 6             | 0             | 0             | 6             | 0             |
| Hong Kong      | 6             | 0             | 0             | 6             | 0             |
| South Africa   | 6             | 0             | 0             | 6             | 0             |
| Australia      | 11            | 2             | 0             | 11            | 2             |
| New Zealand    | 8             | 0             | 0             | 8             | 0             |
| Singapore      | 6             | 0             | 0             | 6             | 0             |
| Malaysia       | 6             | 0             | 0             | 6             | 0             |

| <b>Address</b> | <b>4804B9</b> | <b>4804BA</b> | <b>4804BB</b> | <b>4804BC</b> | <b>4804BD</b> |
|----------------|---------------|---------------|---------------|---------------|---------------|
| France         | 0             | 15            | 0             | 0             | 0BH           |
| Germany        | FEH           | 15            | 0             | 0             | 18H           |
| UK             | 0             | 15            | 0             | 0             | 0BH           |
| Italy          | 0             | 15            | 0             | 0             | 0BH           |
| Austria        | 0             | 15            | 0             | 0             | 0BH           |
| Belgium        | 0             | 15            | 0             | 0             | 0BH           |
| Denmark        | 0             | 15            | 0             | 0             | 0BH           |
| Finland        | 0             | 15            | 0             | 0             | 0BH           |
| Ireland        | 0             | 15            | 0             | 0             | 0BH           |
| Norway         | 0             | 15            | 0             | 0             | 0BH           |
| Sweden         | 0             | 15            | 0             | 0             | 0BH           |
| Switzerland    | FFH           | 15            | 0             | 0             | 0BH           |
| Portugal       | 0             | 15            | 0             | 0             | 0BH           |
| Holland        | 0             | 15            | 0             | 0             | 0BH           |
| Spain          | 0             | 15            | 0             | 0             | 0BH           |
| Israel         | 0             | 15            | 0             | 0             | 0BH           |
| USA            | 0             | 15            | 0             | 0             | 0DH           |
| Asia           | 0             | 15            | 0             | 0             | 0DH           |
| Hong Kong      | 0             | 15            | 0             | 0             | 0BH           |
| South Africa   | 0             | 15            | 0             | 0             | 0BH           |
| Australia      | 0             | 15            | 0             | 0             | 0BH           |
| New Zealand    | 0             | 15            | 0             | 0             | 0BH           |
| Singapore      | 0             | 15            | 0             | 0             | 0BH           |
| Malaysia       | 0             | 15            | 0             | 0             | 0BH           |

| <b>Address</b> | <b>4804DA</b> |  |  |  |  |
|----------------|---------------|--|--|--|--|
| France         | 53            |  |  |  |  |
| Germany        | 53            |  |  |  |  |
| UK             | 53            |  |  |  |  |
| Italy          | 53            |  |  |  |  |
| Austria        | 59            |  |  |  |  |
| Belgium        | 59            |  |  |  |  |
| Denmark        | 53            |  |  |  |  |
| Finland        | 53            |  |  |  |  |
| Ireland        | 53            |  |  |  |  |
| Norway         | 53            |  |  |  |  |
| Sweden         | 53            |  |  |  |  |
| Switzerland    | 92            |  |  |  |  |
| Portugal       | 53            |  |  |  |  |
| Holland        | 53            |  |  |  |  |
| Spain          | 80            |  |  |  |  |
| Israel         | 59            |  |  |  |  |
| USA            | 53            |  |  |  |  |
| Asia           | 47            |  |  |  |  |
| Hong Kong      | 53            |  |  |  |  |
| South Africa   | 53            |  |  |  |  |
| Australia      | 53            |  |  |  |  |
| New Zealand    | 53            |  |  |  |  |
| Singapore      | 53            |  |  |  |  |
| Malaysia       | 53            |  |  |  |  |

# **ISDN Unit (Machine Code: A644)**

July 31st, 1996

Subject to change

**SECTION 1**  
**INSTALLATION**



# 1. INSTALLATION PROCEDURE

Install the hardware as described in Chapter 3 of the host fax machine's service manual. Then program the following items.

## 1.1 USER LEVEL PROGRAMMING

The following items can be programmed with user function 61. Make sure that the items are programmed correctly.

| Item                  | ISDN |    | PSTN | Remarks   |
|-----------------------|------|----|------|---|
|                       | G4   | G3 | G3   |   |
| Own analog number     |      |    | ✓    | Used for transfer operations in PSTN G3 communication                 |
| Own ISDN-G4 number    | ✓    |    |      | Used for transfer operations in ISDN G4 communication.                |
| Own ISDN-G3 number    |      | ✓  |      | Used for transfer operations in ISDN G3 communication.                |
| Polling ID            | ✓    | ✓  | ✓    | Used for secured polling, transfer operations, and closed network.    |
| Confidential ID       | ✓    | ✓  | ✓    | Used for confidential reception. Optional SAF memory required.        |
| Memory lock ID        | ✓    | ✓  | ✓    | Used for memory lock. Optional SAF memory required.                   |
| RTI                   |      | ✓  | ✓    | Used to identify the terminal in G3 NSF/NSS communications.           |
| TTI                   |      | ✓  | ✓    | Printed on each transmitted page in G3 communications.                |
| G4_TID (Terminal ID)  | ✓    |    |      | Used to identify the terminal in G4 communications.                   |
| CSI                   |      |    | ✓    | Used to identify the terminal in G3 DIS/DCS communications over PSTN. |
| IG3_CSI (ISDN G3 CSI) |      | ✓  |      | Used to identify the terminal in G3 communications over an ISDN.      |

## 1.2 SERVICE LEVEL PROGRAMMING

| Item                          | Function No. | Remarks  |
|-------------------------------|--------------|--|
| System Switches               | 01 - 0       | <b>System Switch 0A</b><br>- Network used for G3 transmission<br>- Network used for G4-to-G3 fallback  |
| Communication Switches        | 01 - 4       | <b>Communication Switch 07</b><br>- G4-to-G3 fallback On/Off   |
| G4 internal switches          | 17 - 01      | Change the country code, and reset the machine first. Then change any of the locally required settings and/or the following.   |
| G4 parameter switches         | 17 - 02      | <b>Internal Switches 17, 18, 1A, 1B and 1C</b><br>- G4 to G3 automatic fallback parameters<br><b>Parameter Switch 01, bits 4 to 6</b><br>- Codec attenuation level   |
| ISDN international prefix     | 17 - 03      | Program the international access code.   |
| G4 subscriber number - 1      | 17 - 04      | <b>When not using MSN* service:</b><br>Program the ISDN subscriber number here. If an another terminal is on the same bus from the DSU, identify the terminals using a sub-address.  |
| G4 subscriber number - 2      | 17 - 05      | <b>When using MSN* service:</b><br>Program the dedicated ISDN number for the terminal as the 1st ISDN subscriber number. If the customer wishes the machine to answer the calls to a different number, program it as the 2nd subscriber number.  |
| ISDN G3 subscriber number - 1 | 17 - 06      | <b>When not using MSN* service:</b><br>Program the ISDN subscriber number here.  |
| ISDN G3 subscriber number - 2 | 17 - 07      | If an another terminal is on the same bus from the DSU, identify the terminals using a sub-address.<br><b>When using MSN* service:</b><br>Program the dedicated ISDN number for the terminal as the 1st ISDN subscriber number. If the customer wishes the machine to answer the calls to a different number, program it as the 2nd subscriber number. |
| G4 subaddress                 | 17 - 08      | Program a subaddress to identify the terminal, if two or more terminals answer the call to the subscriber number for G4 fax.   |
| ISDN G3 subaddress            | 17 - 09      | Program a subaddress to identify the terminal, if two or more terminals answer the call to the subscriber number for G3 fax.   |

\* MSN = Multiple Subscriber Number; This is also referred to as "Direct Dialing In" in some countries

After changing any setting, make sure to turn off the machine, wait for 5 or more seconds, then turn it back on, so that the new settings take effect.

## 2. SWITCH SETTINGS

The following tables show the default settings of the Internal Switches and the Parameter Switches for each country setting.

### 2.1 INTERNAL SWITCHES

| Switch No.         | USA   | Europe                              | Asia                          | Germany<br>(1TR6) | France<br>(CNET) |
|--------------------|-------|-------------------------------------|-------------------------------|-------------------|------------------|
| 00<br>Country code | 11(H) | European<br>country code<br>setting | Asian country<br>code setting | 01(H)             | 00(H)            |
| 01                 | 00(H) | 00(H)                               | 00(H)                         | 00(H)             | 00(H)            |
| 02                 | 00(H) | 00(H)                               | 00(H)                         | 00(H)             | 00(H)            |
| 03                 | 00(H) | 00(H)                               | 00(H)                         | 00(H)             | 00(H)            |
| 04                 | 00(H) | 00(H)                               | 00(H)                         | 20(H)             | 00(H)            |
| 05                 | 00(H) | 00(H)                               | 00(H)                         | 00(H)             | 00(H)            |
| 06                 | 00(H) | 00(H)                               | 00(H)                         | 00(H)             | 00(H)            |
| 07                 | 00(H) | 00(H)                               | 00(H)                         | 00(H)             | 00(H)            |
| 08                 | 00(H) | 00(H)                               | 00(H)                         | 00(H)             | 00(H)            |
| 09                 | 00(H) | 00(H)                               | 00(H)                         | 02(H)             | 00(H)            |
| 0A                 | 00(H) | 00(H)                               | 00(H)                         | 00(H)             | 00(H)            |
| 0B                 | 00(H) | 00(H)                               | 00(H)                         | 00(H)             | 00(H)            |
| 0C                 | 00(H) | 00(H)                               | 00(H)                         | 00(H)             | 00(H)            |
| 0D                 | 00(H) | 00(H)                               | 00(H)                         | 00(H)             | 00(H)            |
| 0E                 | 00(H) | 00(H)                               | 00(H)                         | 00(H)             | 00(H)            |
| 0F                 | 00(H) | 00(H)                               | 00(H)                         | 00(H)             | 00(H)            |
| 10                 | 10(H) | 10(H)                               | 10(H)                         | 10(H)             | 10(H)            |
| 11                 | 00(H) | 00(H)                               | 00(H)                         | 01(H)             | 00(H)            |
| 12                 | 00(H) | 00(H)                               | 00(H)                         | 00(H)             | 00(H)            |
| 13                 | 00(H) | 00(H)                               | 00(H)                         | 00(H)             | 00(H)            |
| 14                 | 01(H) | 00(H)                               | 00(H)                         | 00(H)             | 00(H)            |
| 15                 | 00(H) | 00(H)                               | 00(H)                         | 00(H)             | 00(H)            |
| 16                 | 00(H) | 00(H)                               | 00(H)                         | 01(H)             | 02(H)            |
| 17                 | 00(H) | 00(H)                               | 00(H)                         | 00(H)             | 00(H)            |
| 18                 | 00(H) | 00(H)                               | 00(H)                         | 00(H)             | 00(H)            |
| 19                 | 01(H) | 00(H)                               | 00(H)                         | 00(H)             | 00(H)            |
| 1A                 | 00(H) | 00(H)                               | 00(H)                         | 00(H)             | 00(H)            |
| 1B                 | 00(H) | 00(H)                               | 00(H)                         | 00(H)             | 00(H)            |
| 1C                 | 00(H) | 00(H)                               | 00(H)                         | 00(H)             | 00(H)            |
| 1D                 | 00(H) | 00(H)                               | 00(H)                         | 00(H)             | 00(H)            |
| 1E                 | 00(H) | 00(H)                               | 00(H)                         | 00(H)             | 00(H)            |
| 1F                 | 00(H) | 00(H)                               | 00(H)                         | 00(H)             | 00(H)            |

## 2.2 PARAMETER SWITCHES

| Switch No. | USA   | Europe | Asia  | Germany<br>(1TR6) | France<br>(CNET) |
|------------|-------|--------|-------|-------------------|------------------|
| 00         | 00(H) | 00(H)  | 00(H) | 00(H)             | 00(H)            |
| 01         | 30(H) | 21(H)  | 21(H) | 30(H)             | 30(H)            |
| 02         | 01(H) | 00(H)  | 00(H) | 00(H)             | 00(H)            |
| 03         | 00(H) | 00(H)  | 00(H) | 00(H)             | 00(H)            |
| 04         | 07(H) | 07(H)  | 07(H) | 07(H)             | 07(H)            |
| 05         | 02(H) | 02(H)  | 02(H) | 06(H)             | 02(H)            |
| 06         | 00(H) | 00(H)  | 00(H) | 01(H)             | 00(H)            |
| 07         | 0B(H) | 0B(H)  | 0B(H) | 0B(H)             | 0B(H)            |
| 08         | 07(H) | 07(H)  | 07(H) | 07(H)             | 07(H)            |
| 09         | 00(H) | 00(H)  | 00(H) | 00(H)             | 00(H)            |
| 0A         | 01(H) | 01(H)  | 01(H) | 01(H)             | 01(H)            |
| 0B         | 0B(H) | 0B(H)  | 0B(H) | 07(H)             | 0B(H)            |
| 0C         | 01(H) | 01(H)  | 01(H) | 01(H)             | 01(H)            |
| 0D         | 00(H) | 00(H)  | 00(H) | 00(H)             | 00(H)            |
| 0E         | B2(H) | B2(H)  | B2(H) | B2(H)             | B2(H)            |
| 0F         | 00(H) | 00(H)  | 00(H) | 00(H)             | 00(H)            |

**SECTION 2**

**SERVICE TABLES AND  
PROCEDURES**

---

# 1. SERVICE LEVEL FUNCTIONS

Refer to the "Fax Unit Type 250" service manual for how to enter service mode, and how to operate with functions.

| <b>Function Number</b> | <b>Description</b>                                  |
|------------------------|---|
| 01                     | Programming G4 International and Parameter switches |
| 02                     | Printing G4 System Parameter List                   |
| 05                     | G4 Protocol Dump Lists                              |
| 06                     | G4 RAM read/write and printing G4 Memory Dump List  |
| 11                     | ISDN G3 CCU tests                                   |
| 12                     | Programming ISDN parameters                         |

## 2. BIT SWITCHES

### WARNING

Do not adjust a bit switch that is described as "Not used", as this may cause the machine to malfunction or to operate in a manner that is not accepted by local regulations. Such bits are for use only in other areas, such as Japan.

**Note:** After changing any of the switches below, turn off the machine, wait for 5 seconds or more, and turn it back on, so that the new settings take effect.

### 2.1 G4 INTERNAL SWITCHES

| Bit Switch 00   |               | FUNCTION            | COMMENTS |
|---|---------------|---------------------|----------|
| 0<br>to<br>7  | Country code  |                     |          |
|   | Bit 4 3 2 1 0 | Country             |          |
|   | 0 0 0 0 0     | France              |          |
|   | 0 0 0 0 1     | Germany (1TR6 mode) |          |
|   | 0 0 0 1 0     | UK                  |          |
|   | 0 0 0 1 1     | Italy               |          |
|   | 0 0 1 0 0     | Austria             |          |
|   | 0 0 1 0 1     | Belgium             |          |
|   | 0 0 1 1 0     | Denmark             |          |
|   | 0 0 1 1 1     | Finland             |          |
|   | 0 1 0 0 0     | Ireland             |          |
|   | 0 1 0 0 1     | Norway              |          |
|   | 0 1 0 1 0     | Sweden              |          |
|   | 0 1 0 1 1     | Switzerland         |          |
|   | 0 1 1 0 0     | Portugal            |          |
|   | 0 1 1 0 1     | Netherlands         |          |
|   | 0 1 1 1 0     | Spain               |          |
|   | 0 1 1 1 1     | Israel              |          |
|   | 1 0 0 0 1     | USA                 |          |
|   | 1 0 0 1 0     | Asia                |          |
|   | 1 0 0 1 1     | Japan               |          |
|   | 1 0 1 0 0     | Hong Kong           |          |
|   | 1 0 1 0 1     | South Africa        |          |
|   | 1 0 1 1 0     | Australia           |          |
|   | 1 0 1 1 1     | New Zealand         |          |
|   | 1 1 0 0 0     | Singapore           |          |
|   | 1 1 0 0 1     | Malaysia            |          |
| <b>Note:</b> In Germany, use the UK setting for the EuroISDN lines. |               |                     |          |

Bit switches 01 and 02 are not used.

| <b>Bit Switch 03</b> |  |  |
|----------------------|--|--|
|                      | <b>FUNCTION</b>  | <b>COMMENTS</b>  |
| <b>0</b>             | Amount of protocol dump data in one protocol dump list<br><b>0:</b> Last communication only<br><b>1:</b> Up to the limit of the memory area for protocol dumping | Change this bit to 0 if you want to have a protocol dump list of the last communication only.<br>This bit is only effective for the dump list #2 (D + Bch1). |
| <b>1 to 7</b>        | Not used   | Do not change the factory settings.  |

| <b>Bit Switch 04</b> |   |   |
|----------------------|---|---|
|                      | <b>FUNCTION</b>                               | <b>COMMENTS</b>   |
| <b>0 to 4</b>        | Not used                                      | Do not change the factory settings.   |
| <b>5</b>             | RCBCTR<br><b>0:</b> Not valid <b>1:</b> Valid | This bit is used in Germany; set it to 1 for German PTT approval tests.<br><b>1:</b> RCBCTR counts consecutive R:RNR signals. If the counter reaches the value of N2, the link is disconnected. |
| <b>6 to 7</b>        | Not used                                      | Do not change the factory settings.   |

| <b>Bit Switch 05</b> |   |   |
|----------------------|---|---|
|                      | <b>FUNCTION</b>   | <b>COMMENTS</b>   |
| <b>0</b>             | Not used  | Do not change the factory setting.  |
| <b>1</b>             | Logical channel number (LCN)<br><b>0:</b> Not controlled<br><b>1:</b> Fixed at 01 | This bit is normally 0. However, some networks may require a fixed LCN. In such cases, this bit should be 1, and you may have to set a different value for the LCN using G4 Parameter Switch A. |
| <b>2</b>             | Protocol ID check<br><b>0:</b> Yes <b>1:</b> No                                   | The Protocol ID is in the CR packet.  |
| <b>3 to 7</b>        | Not used  | Do not change the factory settings.   |



| <b>Bit Switch 06</b> |   |  |
|----------------------|---|--|
|                      | <b>FUNCTION</b>   | <b>COMMENTS</b>  |
| <b>0</b>             | Inclusion of the DTE address in the S:CR packet<br><b>0:</b> No <b>1:</b> Yes | When the CR packet format matches ISO8208 protocol, some networks may require this bit to be set at 1. This bit is only effective if bit 0 of G4 Parameter switch 6 is at 0. |
| <b>1</b>             | Calling and called DTE addresses<br><b>0:</b> Not used <b>1:</b> Used         | This is only for packet networks. The CR packet should contain the rx side's DTE address, but does not have to include the tx side's; it can include it as an option.        |
| <b>2 to 7</b>        | Not used  | Do not change the factory setting.   |

Bit switch 07 and 08 are not used.

| <b>Bit Switch 09</b> |  |   |
|----------------------|--|---|
|                      | <b>FUNCTION</b>  | <b>COMMENTS</b>   |
| <b>0</b>             | Not used   | Do not change the factory setting.  |
| <b>1</b>             | New session within the same call<br><b>0:</b> Not accepted<br><b>1:</b> Accepted | <b>0:</b> If a new R:CSS is received, the machine sends back S:RSSN.<br><b>1:</b> If a new R:CSS is received, the machine sends back S:RSSP. Set this bit to 1 for German PTT approval tests. |
| <b>2 to 7</b>        | Not used   | Do not change the factory settings.   |

Bit switches 0A to 0F are not used.

| <b>Bit Switch 10 (Dch. Layer 1)</b> |  |  |
|-------------------------------------|--|--|
|                                     | <b>FUNCTION</b>  | <b>COMMENTS</b>  |
| <b>0</b>                            | Connection detector<br><b>0:</b> Disabled <b>1:</b> Enabled            | In most countries (including Europe), this should be disabled.   |
| <b>1</b>                            | Layer 1 T3 timer   | This should be kept at 5 s (both bits at 0) for normal operation. However, you may have to change this during PTT approval tests.  |
| <b>2</b>                            | <b>Bit 2 1 Time</b><br>0 0 5 s<br>0 1 29 s<br>1 0 10 s<br>1 1 Not used |  |
| <b>3</b>                            | Layer 1 T4 timer<br><b>0:</b> Not used <b>1:</b> Used                  |  |
| <b>4</b>                            | Not used   |  |
| <b>5</b>                            |  | Do not change the factory settings.  |
| <b>6</b>                            | INFO1 signal resend<br><b>0:</b> Resend<br><b>1:</b> No resend         | <b>0:</b> Some DSUs may not reply to the INFO1 signal with INFO2, if there is noise in the INFO1 signal accidentally. Try changing this bit to 0, to resend INFO1 before the machine displays "CHECK INTERFACE". |

| <b>Bit Switch 10 (Dch. Layer 1)</b> |  |  |
|-------------------------------------|--|--|
|                                     | <b>FUNCTION</b>  | <b>COMMENTS</b>  |
| <b>7</b>                            | Loop back 4 mode<br><b>0:</b> Disabled <b>1:</b> Enabled | This is normally kept at 0. However, set it to 1 for British PTT approval tests. |

| <b>Bit Switch 11 (Dch. Layer 2)</b> |   |   |
|-------------------------------------|---|---|
|                                     | <b>FUNCTION</b>   | <b>COMMENTS</b>   |
| <b>0</b>                            | Not used  | Do not change the factory setting.  |
| <b>1</b>                            | Type of TEI used<br><b>0:</b> Dynamic TEI<br><b>1:</b> Static TEI | This is normally fixed at 0. However, some networks such as the Northern Telecom ISDN may require this bit to be set at 1 (see below). In this case, you may have to change the values of bits 2 to 7.  |
| <b>2 to 7</b>                       | Static TEI value  | This is used in the USA with the DMS100 (Northern Telecom ISDN) exchanger.<br>Store the lowest bit of the TEI at bit 7 and the highest bit of the TEI at bit 2.<br><b>Example:</b> If the static TEI is 011000, set bits 3 and 4 to 1 and bits 2, 5, 6, and 7 to 0. |

Bit switch 12 is not used. Do not change any of the factory settings.

| <b>Bit Switch 13: D channel layer 3 (Attachment IE in S: SETUP)</b> |   |  |
|---|---|--|
|   | <b>FUNCTION</b>   | <b>COMMENTS</b>  |
| <b>0</b>  | Not used  | Do not change the factory settings.  |
| <b>1</b>  |   |  |
| <b>2</b>  | Attachment of calling ID<br><b>0:</b> No <b>1:</b> Yes                    | Normally, this bit should be at 0, because most networks add the calling ID to the SETUP signal to the receiver. However, some networks may require the machine to add this ID. Only in this case should this bit be at 1. |
| <b>3</b>  | Attachment of the Lower Layer Capabilities<br><b>0:</b> No <b>1:</b> Yes  | This bit determines whether Lower Layer Capabilities are informed in the [SETUP] signal or not. Keep this bit at 0 in most cases.  |
| <b>4</b>  | Attachment of the Higher Layer Capabilities<br><b>0:</b> Yes <b>1:</b> No | This bit determines whether Higher Layer Capabilities are informed in the [SETUP] signal or not. Keep this bit at 0 in most cases.   |
| <b>5 to 7</b>   | Not used  | Do not change the factory settings.  |

| <b>Bit Switch 14: D channel layer 3 (Selection IE in S: SETUP)</b> |   |   |
|--|---|---|
|  | <b>FUNCTION</b>   | <b>COMMENTS</b>   |
| <b>0</b>   | ISDN G3 information transfer capability<br><b>0:</b> 3.1 kHz audio<br><b>1:</b> Speech  | In tx mode, this determines the information transfer capability informed in the [SETUP] message.<br>In rx mode, this determines the information transfer capability that the machine can use to receive a call. Refer to Appendix C for more details.<br>Set this bit to 1 if the ISDN does not support 3.1 kHz audio. This bit is only used in the USA and the UK. |
| <b>1</b>   | Not used  | Do not change the factory settings.   |
| <b>2</b>   |   |   |
| <b>3</b><br><b>4</b>   | Channel selection in [SETUP] in tx mode<br>Bit 4 3 Setting<br>0 0 Any channel<br>0 1 B1 channel<br>1 0 B2 channel<br>1 1 Not used | <b>Any channel:</b> When this is informed to the exchanger, the exchanger will select either B1 or B2.  |
| <b>5</b>   | Called ID mapping<br><b>0:</b> Called party number<br><b>1:</b> Keypad facility   | <b>0:</b> Called ID is mapped to the called party number.<br><b>1:</b> Called ID is mapped to the keypad facility.<br>On the 5ESS network (USA), set it to 1.   |
| <b>6</b>   | Numbering plan for the called party number<br><b>0:</b> Unknown<br><b>1:</b> E.164  | <b>E.164:</b> This may be used in Sweden if an AXE10 exchanger is fitted with old software, and in Australia.<br><b>Unknown:</b> This is the normal setting.  |
| <b>7</b>   | Subaddress coding type<br><b>0:</b> IA5 (NSAP)<br><b>1:</b> BCD (ISO8348)   | This is normally kept at 0. However, some networks require this bit to be at 1.   |

| <b>Bit Switch 15: D channel layer 3 (Judgement R: MSG)</b> |  |   |
|--|--|---|
|  | <b>FUNCTION</b>  | <b>COMMENTS</b>   |
| <b>0</b>   | Action when receiving [SETUP] signal containing no called subaddress, if the subaddress was programmed in the dialed number<br><b>0:</b> A reply is sent<br><b>1:</b> No reply is sent | This bit depends on user requirements. If it is at 1, communication will be halted if the other terminal has not input the subaddress.<br>Refer to Appendix C for more details. |
| <b>1</b><br><b>to</b><br><b>4</b>                          | Not used   | Do not change the factory settings  |
| <b>5</b>   | Global call reference<br><b>0:</b> Ignored<br><b>1:</b> Global call number is used   |   |
| <b>6</b>   | Not used   | Do not change the factory settings.   |
| <b>7</b>   |  |   |

| <b>Bit Switch 16: D channel layer 3 (Approval)</b> |  |   |
|--|--|---|
|  | <b>FUNCTION</b>  | <b>COMMENTS</b>   |
| <b>0</b>   | Answer delay time  | <p>In Germany (1TR6) and France (CNET), a time delay to answer a call is required.</p> <p>In other countries, use this switch as follows:</p> <p>If the machine is connected to the same bus from the DSU as a model K200 is connected, the machine receives most of the calls because the response time to a call is faster than the K200.</p> <p>If the customer wants the K200 to receive most of the calls, adjust the response time using these bits.</p> <p>If the customer does not want one machine to receive most of the calls, use subaddresses to identify each terminal.</p> |
|  | Bit 1 0 Setting  |   |
| <b>1</b>   | 0 0 No delay   |   |
|  | 0 1 1.0 s delayed (1TR6)   |   |
|  | 1 0 0.5 s delayed (CNET)   |   |
|  | 1 1 Not used   |   |
| <b>2</b>   | Action when receiving [SETUP] signal containing user-specific callrd party subaddress<br><b>0:</b> Ignores the call<br><b>1:</b> Receives the call | <p>Normally, the 3rd octet of called party subaddress information in the [SETUP] signal is set to NSAP. However, some networks may add "user-specific" subaddress to the [SETUP] signal (UK), and the result of this is that the machine won't answer the call if a subaddress is specified.</p> <p>So, change this bit to 1 to let the machine receive the call if the machine is connected to such a network.</p>   |
| <b>3</b>   | Not used   | Do not change the factory settings.   |
| <b>4</b>   |  |   |
| <b>5</b>   | Indicated bearer capabilities<br><b>0:</b> 56 kbps <b>1:</b> 64 kbps   | <b>1:</b> 64 kbps calling is indicated in the Bearer Capabilities, but communication is at 56 k. Use this bit if the machine is connected to a network which does not accept a 56 kbps data transfer rate as a bearer capability.   |
| <b>6</b>   | Not used   | Do not change the factory settings.   |
| <b>7</b>   |  |   |

| <b>Bit Switch 17: CPS Code Used for G4 to G3 Fallback - 1</b> |                                      |   |
|---|--------------------------------------|---|
|   | <b>FUNCTION</b>                      | <b>COMMENTS</b>   |
| <b>0 to 6</b>   | Condition for fallback from G4 to G3 | <p>Bits 0 to 6 of bit switch 17 contain a CPS code, and bits 0 to 6 of bit switch 18 contain another CPS code. If a CPS code is received which is the same as either of these, communication will fall back from ISDN G4 mode to ISDN G3 mode.</p> <p>The CPS codes must be the same as those specified in table 4-13 of CCITT recommendation Q.931.</p> <p>Examples: Bit 6 5 4 3 2 1 0</p> <p>1 0 0 0 0 0 1 CPS code 65</p> <p>1 0 1 1 0 0 0 CPS code 88</p> |
|   |                                      |   |
|   |                                      | <p>For the codes in bits 0 to 6 of bit switches 17 and 18 to be recognized, bit 7 of bit switch 17 must be 1. Also, bit 0 of the Communication Switch 07 must be at 0, or Fallback from G4 to G3 will be disabled.</p>  |

| <b>Bit Switch 17: CPS Code Used for G4 to G3 Fallback - 1</b> |   |
|---|---|
| <b>FUNCTION</b>   | <b>COMMENTS</b>   |
| <b>7</b>  | <p>This bit determines whether fallback from G4 to G3 occurs on receipt of one of the CPS codes programmed in bit switch 17 or 18, or on receipt of a certain standard code.</p> <p><b>0:</b> Fallback occurs on receipt of any of the following CPS codes:<br/>           UK (EuroISDN mode) - #3, #18, #57, #58, # 63, # 65, #79, #88, and #127<br/>           Germany (1TR6 mode) - #3, #31, #53, #58, #62, #89, and #90<br/>           France - #3, #65, #88, and #113<br/>           Others - #3, #65, and #88</p> <p><b>1:</b> Fallback from G4 to G3 occurs on receipt any of above CPS codes or one of the CPS codes programmed in bit switch 17, 18, 1A, 1B, or 1C</p> |

| <b>Bit Switch 18: CPS Code Used for G4 to G3 Fallback - 2</b> |   |
|---|---|
| <b>FUNCTION</b>   | <b>COMMENTS</b>   |
| <b>0 to 6</b>   | <p>Condition for fallback from G4 to G3</p> <p>See the explanation for bits 0 to 6 of bit switch 17</p>   |
| <b>7</b>  | <p>This bit helps to choose the CPS code set for G4 to G3 fallback.</p> <p><b>0:</b> Fallback occurs on receipt of the CPS code set which is specified by the country code setting.</p> <p><b>1:</b> Fallback occurs on receipt of the UK CPS code set (#3, #18, #57, #58, # 63, # 65, #79, #88, and #127) even if another counry code is programmed.</p> |

| <b>Bit Switch 19</b> |  |  |
|----------------------|--|--|
|                      | <b>FUNCTION</b>  | <b>COMMENTS</b>  |
| <b>0</b>             | Permanence of the link<br><b>0:</b> Set/released each LAPD call<br><b>1:</b> Permanent | Keep this at 1 in the USA. In other areas, this bit is normally 0, depending on network requirements.      |
| <b>1</b>             | Channel used in ISDN L2 (64k) mode<br><b>0:</b> B1 <b>1:</b> B2                        | When making an ISDN L2 back-to-back test, you can select either the B1 or B2 channel with this bit switch. |
| <b>2 to 7</b>        | Not used   | Do not change the factory settings.  |

| <b>Bit Switch 1A: CPS Code Used for G4 to G3 Fallback - 3</b> |  |                            |
|---|--|----------------------------|
|   | <b>FUNCTION</b>  | <b>COMMENTS</b>            |
| <b>0 to 6</b>   | Condition for fallback from G4 to G3<br>See the explanation for bits 0 to 6 of bit switch 17 |                            |
| <b>7</b>  | Not used.  | Do not change the setting. |

| <b>Bit Switch 1B: CPS Code Used for G4 to G3 Fallback - 4</b> |  |                            |
|---|--|----------------------------|
|   | <b>FUNCTION</b>  | <b>COMMENTS</b>            |
| <b>0 to 6</b>   | Condition for fallback from G4 to G3<br>See the explanation for bits 0 to 6 of bit switch 17 |                            |
| <b>7</b>  | Not used.  | Do not change the setting. |

| <b>Bit Switch 1C: CPS Code Used for G4 to G3 Fallback - 5</b> |  |                            |
|---|--|----------------------------|
|   | <b>FUNCTION</b>  | <b>COMMENTS</b>            |
| <b>0 to 6</b>   | Condition for fallback from G4 to G3<br>See the explanation for bits 0 to 6 of bit switch 17 |                            |
| <b>7</b>  | Not used.  | Do not change the setting. |

Bit switches 1D to 1F are not used. Do not change any of the factory settings.

## 2.2 G4 PARAMETER SWITCHES

| Parameter Switch 00 |  |                                     |
|---------------------|--|-------------------------------------|
|                     | FUNCTION   | COMMENTS                            |
| 0                   | Network type                                     | Do not change the default setting.  |
| 1                   | Bit 2 1 0 Type<br>x 0 0 Circuit<br>switched ISDN |                                     |
| 2                   | Other settings: Not<br>used                      |                                     |
| 3<br>to<br>7        | Not used   | Do not change the default settings. |

| Parameter Switch 01 |   |  |
|---------------------|---|--|
|                     | FUNCTION  | COMMENTS   |
| 0                   | Voice coding<br>0: $\mu$ law<br>1: A law  | 0: This setting is used in Japan, Taiwan, and the USA.<br>1: This setting is used in Europe and Asia.  |
| 1                   | Action when [SETUP]<br>signal without HLC is<br>received<br>0: Respond to the call<br>1: Not respond to the<br>call   | If there are several TEs on the same bus and the machine<br>responds to calls for another TE, the call may be without HLC<br>information.<br>Identify the type of calling terminal and change this bit to 1 if<br>the caller is not a fax machine. |
| 2                   | Not used  | Do not change the default settings.  |
| 3                   |   |  |
| 4<br>5<br>6         | Signal attenuation level for G3 fax signals received from ISDN line.<br>If an analog signal comes over an digital line, the signal level after decoding by the TE<br>is theoretically the same as the level at the entrance to the digital line. However, this<br>sometimes causes the received signal level to be too high at the received end. In this<br>case, adjust the decoded signal's attenuation level using these switches.<br>The values in the "Codec" column below show the attenuation level at the G4 interface<br>board. The values in the "Modem" column show the <u>actual attenuation level</u> at the<br>modem, because the signal is attenuated again on the MFCE by -6dB. |  |
|                     | Bit 6 5 4 Codec Modem (Actual attenuation level)  |  |
|                     | 0 0 0 -4.5dB -10.5dB  |  |
|                     | 0 0 1 -2.5dB -8.5dB   |  |
|                     | 0 1 0 -0.5dB -6.5dB   |  |
|                     | 0 1 1 +1.5dB -4.5dB (default setting)   |  |
|                     | 1 0 0 +3.5dB -2.5dB   |  |
|                     | 1 0 1 +5.5dB -0.5dB   |  |
|                     | 1 1 0 +7.5dB +1.5dB   |  |
|                     | 1 1 1 +9.5dB +3.5dB   |  |
| 7                   | Not used  | Do not change the default settings.  |

| <b>Parameter Switch 02</b> |                                     |                                     |
|----------------------------|-------------------------------------|-------------------------------------|
|                            | <b>FUNCTION</b>                     | <b>COMMENTS</b>                     |
| <b>0</b>                   | Data rate (kbps)<br>Bit 1 0 Setting | Other settings: Not used            |
| <b>1</b>                   | 0 0 64 kbps<br>0 1 56 kbps          |                                     |
| <b>2</b>                   | Not used                            |                                     |
| <b>3</b>                   |                                     | Do not change the default settings. |
| <b>4</b>                   | Transmission mode<br>Bit 5 4 Mode   | Other settings: Not used            |
| <b>5</b>                   | 0 0 CS                              |                                     |
| <b>6</b>                   | Not used                            | Do not change the default settings. |
| <b>7</b>                   |                                     |                                     |

| <b>Parameter Switch 03</b> |                                    |   |
|----------------------------|------------------------------------|---|
|                            | <b>FUNCTION</b>                    | <b>COMMENTS</b>   |
| <b>0</b>                   | Link modulus<br><b>0: 8 1: 128</b> | This setting determines whether protocol frame numbering is done using 3 bits (0 to 7 then start again at 0) or 7 bits (0 to 127 then start again at 0). Set this bit switch to match the network's specifications. |
| <b>1 to 7</b>              | Not used                           | Do not change the default settings.   |

Parameter Switch 04 is not used. Do not change any of the default settings.

| <b>Parameter Switch 05</b> |   |  |
|----------------------------|---|--|
|                            | <b>FUNCTION</b>                         | <b>COMMENTS</b>  |
| <b>0</b>                   | Link timer (D-channel layer 2 T1 timer) | The link timer is the maximum allowable time between sending a protocol frame and receiving a response frame from the remote terminal. |
| <b>1</b>                   | Bit 3 2 1 0 Value<br>0 0 0 0 0 s        |  |
| <b>2</b>                   | 0 0 0 1 1 s<br>0 0 1 0 2 s              |  |
| <b>3</b>                   | and so on until<br>1 0 1 0 10 s         |  |
| <b>4 to 7</b>              | Not used                                | Do not change the default settings.  |



| <b>Parameter Switch 06</b> |   |   |
|----------------------------|---|---|
|                            | <b>FUNCTION</b>   | <b>COMMENTS</b>   |
| <b>0</b>                   | Layer 3 protocol<br><b>0:</b> ISO8208<br><b>1:</b> T.70NULL | Set this bit to match the type of layer 3 signalling used by the ISDN.<br>The dedicated parameters have the same setting for specific destinations. |
| <b>1</b>                   | Not used  | Do not change the default settings.   |
| <b>2</b>                   |   |   |
| <b>3</b>                   |   |   |
| <b>4</b>                   | Packet modulus<br><b>0:</b> 8 <b>1:</b> 128                 |   |
| <b>5</b>                   | Not used  | Do not change the default settings.   |
| <b>6</b>                   |   |   |
| <b>7</b>                   |   |   |

| <b>Parameter Switch 07</b> |                                  |   |
|----------------------------|----------------------------------|---|
|                            | <b>FUNCTION</b>                  | <b>COMMENTS</b>   |
| <b>0</b>                   | Packet size<br>Bit 3 2 1 0 Value | This value is sent in the CR packet. This value must match the value stored in the other terminal, or communication will stop (CI will be returned). If the other end returns CI, check the value of the packet window size with the other party.<br>Note that this value must be the same as the value programmed for the transport block size (G4 Parameter Switch B, bits 0 to 3).<br>Normally, do not change the default setting. |
| <b>1</b>                   | 0 1 1 1 128<br>1 0 0 0 256       |   |
| <b>2</b>                   | 1 0 0 1 512<br>1 0 1 0 1024      |   |
| <b>3</b>                   | 1 0 1 1 2048                     |   |
| <b>4 to 7</b>              | Not used                         |   |

| <b>Parameter Switch 08</b> |   |  |
|----------------------------|---|--|
|                            | <b>FUNCTION</b>                         | <b>COMMENTS</b>  |
| <b>0</b>                   | Packet window size<br>Bit 3 2 1 0 Value | This is the maximum number of unacknowledged packets that the machine can send out before having to pause and wait for an acknowledgement from the other end.<br><br>This should be kept at 7 normally.<br><br>If the packet modulus (G4 Parameter Switch 6, bit 4) is 8, the packet window size cannot be more than 7. However, if the packet modulus is 128, the window size can be up to 15. Also, if the layer 3 protocol setting (G4 Parameter Switch 6, bit 0) is at IS8208, the packet window size cannot be more than 7. |
| <b>1</b>                   | 0 0 0 1 1<br>0 0 1 0 2                  |  |
| <b>2</b>                   | and so on until<br>1 1 1 1 15           |  |
| <b>3</b>                   |   |  |
| <b>4 to 7</b>              | Not used                                | Do not change the default settings.  |

| <b>Parameter Switch 09</b> |                   |                                     |
|----------------------------|-------------------|-------------------------------------|
|                            | <b>FUNCTION</b>   | <b>COMMENTS</b>                     |
| <b>0</b>                   | LCGN              | Keep the value of the LCGN at 0.    |
|                            | Bit 3 2 1 0 Value |                                     |
| <b>1</b>                   | 0 0 0 0 0         |                                     |
|                            | 0 0 0 1 1         |                                     |
| <b>2</b>                   | 0 0 1 0 2         |                                     |
|                            | and so on until   |                                     |
| <b>3</b>                   | 1 1 1 1 15        |                                     |
| <b>4 to 7</b>              | Not used          | Do not change the default settings. |

| <b>Parameter Switch 0A</b> |                           |                                    |
|----------------------------|---------------------------|------------------------------------|
|                            | <b>FUNCTION</b>           | <b>COMMENTS</b>                    |
| <b>0</b>                   | LCN                       | Keep at the value of the LCN at 1. |
| <b>1</b>                   | Bit 7 6 5 4 3 2 1 0 Value |                                    |
| <b>2</b>                   | 0 0 0 0 0 0 0 1 1         |                                    |
| <b>3</b>                   | 0 0 0 0 0 0 1 0 2         |                                    |
| <b>4</b>                   | 0 0 0 0 0 0 1 1 3         |                                    |
| <b>5</b>                   | and so on until           |                                    |
| <b>6</b>                   | 1 1 1 1 1 1 1 1 255       |                                    |
| <b>7</b>                   |                           |                                    |

| <b>Parameter Switch 0B</b> |                      |  |
|----------------------------|----------------------|--|
|                            | <b>FUNCTION</b>      | <b>COMMENTS</b>  |
| <b>0</b>                   | Transport block size | This value must match the value set in the other terminal. Note that this value must be the same as the value programmed for the packet size (G4 Parameter Switch 7, bits 0 to 3). Also, the transport block size is limited by the amount of memory in the remote terminal. |
|                            | Bit 3 2 1 0 Value    |  |
| <b>1</b>                   | 0 1 1 1 128          |  |
|                            | 1 0 0 0 256          |  |
| <b>2</b>                   | 1 0 0 1 512          |  |
|                            | 1 0 1 0 1024         |  |
| <b>3</b>                   | 1 0 1 1 2048         |  |
| <b>4 to 7</b>              | Not used             | Do not change the default settings.  |

Parameter Switch 0C is not used. Do not change any of the default settings.

| <b>Parameter Switch 0D</b> |                                 |   |
|----------------------------|---------------------------------|---|
|                            | <b>FUNCTION</b>                 | <b>COMMENTS</b>   |
| <b>0</b>                   | Back-to-back test mode          | When doing a back-to-back test or doing a demonstration without a line simulator, use these bits to set up one of the machines in TE mode, and the other in NT mode. After the test, return both bits to 0. See "Back-to-back Testing" in the Troubleshooting section for full details. |
|                            | Bit 1 0 Setting                 |   |
| <b>1</b>                   | 0 0 Off                         |   |
|                            | 0 1 Not used                    |   |
|                            | 1 0 ISDN L2 test mode (TE mode) |   |
|                            | 1 1 ISDN L2 test mode (NT mode) |   |
| <b>2 to 7</b>              | Not used                        | Do not change the default settings.   |

| <b>Parameter Switch E</b> |   |   |
|---------------------------|---|---|
|                           | <b>FUNCTION</b>   | <b>COMMENTS</b>   |
| <b>0</b>                  | Troubleshooting mode - real time status codes display<br><b>0:</b> Off <b>1:</b> On | If this is switched on, the status codes will be displayed in the lower two lines of the LCD. These codes are explained in the Troubleshooting section (G4CCU Status Codes). Change this bit back to 0 after testing. |
| <b>1</b>                  | Saving frames to the protocol dump list<br><b>0:</b> Off <b>1:</b> On               | Keep this bit at 1 normally.  |
| <b>2 to 7</b>             | Not used  | Do not change the default settings.   |

### 3. DEDICATED TRANSMISSION PARAMETERS

The following G4 communication parameter bytes have been added for each Quick Dial and Speed Dial. For how to program Dedicated Transmission Parameters, refer to the Service Manual for the base machine.

Switches 01 to 04 are for use with Group 3 communication and are explained in the Service Manual for the base machine. Switch 08 is not used.

| Switch 05 |  |
|-----------|--|
|           | FUNCTION   |
| <b>0</b>  | Data rate Bit 3 2 1 0 Setting  |
| <b>1</b>  | 0 0 0 0 64 kbps  |
| <b>2</b>  | 0 0 0 1 56 kbps  |
| <b>3</b>  | 1 1 1 1 As in Parameter Switch 2, bits 0 and 1<br>Other settings: Not used |
| <b>4</b>  | Not used   |
| <b>5</b>  |  |
| <b>6</b>  |  |
| <b>7</b>  |  |

| Switch 06 |   |
|-----------|---|
|           | FUNCTION  |
| <b>0</b>  | Link modulus Bit 3 2 1 0 Setting                                    |
| <b>1</b>  | 0 0 0 0 Modulo 8  |
| <b>2</b>  | 0 0 0 1 Modulo 128  |
| <b>3</b>  | 1 1 1 1 As in Parameter Switch 3, bit 0<br>Other settings: Not used |
| <b>4</b>  | Not used  |
| <b>5</b>  |   |
| <b>6</b>  |   |
| <b>7</b>  |   |

| Switch 07 |   |
|-----------|---|
|           | FUNCTION  |
| <b>0</b>  | Layer 3 protocol Bit 3 2 1 0 Setting                                |
| <b>1</b>  | 0 0 0 0 IS.8208   |
| <b>2</b>  | 0 0 0 1 T.70 NULL   |
| <b>3</b>  | 1 1 1 1 As in Parameter Switch 6, bit 0<br>Other settings: Not used |
| <b>4</b>  | Packet modulus Bit 7 6 5 4 Setting                                  |
| <b>5</b>  | 0 0 0 0 Modulo 8  |
| <b>6</b>  | 0 0 0 1 Modulo 128  |
| <b>7</b>  | 1 1 1 1 As in Parameter Switch 6, bit 4<br>Other settings: Not used |

**SECTION 3**  
**TROUBLESHOOTING**

# 1. ERROR CODES

---

The tables on the following pages show the error codes that will be printed on the Service Monitor Report. See the Service Manual for the base machine for instructions on how to print this report.

The meaning of the numbers in the Action column is as follows.

1. Check Layer 1 signalling with a protocol analyzer to determine the cause of the problem. This may require assistance from a G4 specialist.
2. Repeat the communication. If the problem does not repeat itself, the problem was a temporary one caused by the user connecting the machine to another interface. However, if the problem remains, there is a network problem.
3. There is a network problem.
4. There is a network problem. Do the following:
  - Check the error bit rate of the network. If it is high, contact the network and ask them to improve the line.
  - Check the network speed (is it 56 or 64 kbps), and make sure that the bit switch setting is correct. You may also use the dedicated transmission parameters if this problem only occurs when dialling certain numbers.
  - Check that the user dialled the correct number.
5. There is a network problem, or a problem in the machine at the other end.
6. There is a problem in the machine at the other end; ask a technician to check it.
7. The machine at the other end is not a Group 4 fax terminal.
8. The machine is not compatible with the machine at the other end. A compatibility test is needed.

Error codes related with the errors detected by the FCU are listed in the Service Manual of the main body.

## 1.1. D-CANNEL LAYER MANAGEMENT

| Code | Probable Cause                           | Action |
|------|--|--------|
| 7-00 | Link reset                               | 2      |
| 7-01 | Link set-up failed because of time-out.  | 2      |
| 7-02 | Link release failed because of time-out. | 2      |
| 7-03 | Link set-up parameter error              | 2      |

## 1.2. D-CANNEL, LAYER 1

| Code | Probable Cause                        | Action |
|------|---------------------------------------|--------|
| 7-10 | T3 timeout (layer 1 activation error) | 1      |
| 7-11 | No connection on the S0 interface     | 1      |
| 7-12 | Deactivated                           | 1      |

## 1.3. D-CANNEL LINK LAYER

| Code | Probable Cause   | Action   |
|------|--|----------|
| 7-20 | At the start of link set-up, the machine received an unsolicited S (F=1).  | 2        |
| 7-21 | At the start of link set-up, the machine received an unsolicited DM (F=1). | 2        |
| 7-22 | At TEI release, the machine received an unsolicited UA (F=1).              | 2        |
| 7-23 | At the start of link set-up, the machine received an unsolicited DM (F=0). | 2        |
| 7-24 | At TEI release, the machine received an unsolicited UA (F=0).              | 2        |
| 7-25 | SABME received at the start of network link set-up                         | No error |
| 7-26 | N200 retransmission error for SABME  | 2        |
| 7-27 | N200 retransmission error for DISC   | 2        |
| 7-28 | N200 retransmission error for situation enquiry (RR)                       | 2        |
| 7-29 | N(R) sequence number error   | 3        |
| 7-30 | N(S) sequence number error   | 3        |
| 7-31 | FRMR received  | 3        |
| 7-32 | Non-standard frame received  | 3        |
| 7-33 | Abnormal frame length  | 3        |
| 7-34 | N201 error; information field N in the I frame exceeded N201               | 3        |
| 7-35 | T201 timeout; timeout while waiting for checking                           | 3        |
| 7-36 | T202 timeout; timeout while waiting for ID assignment                      | 3        |

## 1.4. D-CHANNEL NETWORK LAYER

| Code | Probable Cause   | Action |
|------|--|--------|
| 7-40 | Insufficient mandatory information elements              | 3      |
| 7-41 | Abnormal LI for a mandatory information element          | 3      |
| 7-42 | T301 timeout; timeout while waiting for R:CONN           | 3      |
| 7-43 | T303 timeout; timeout while waiting for R:CALL-PROC etc. | 3      |
| 7-44 | T304 timeout; timeout while waiting for R:CALL-PROC etc. | 3      |
| 7-45 | T305 timeout; timeout while waiting for R:REL            | 3      |
| 7-46 | T308 timeout; timeout while waiting for R:REL-COMP       | 3      |
| 7-47 | T310 timeout; timeout while waiting for R:ALERT etc.     | 3      |
| 7-48 | T313 timeout; timeout while waiting for R:CONN-ACK       | 3      |
| 7-49 | Internal error   | 3      |
| 7-51 | Release call reference during communication              | 3      |

## 1.5. B-CHANNEL LINK LAYER

| Code | Probable Cause   | Action |
|------|--|--------|
| 7-60 | T3 timeout; timeout while waiting for flag   | 4      |
| 7-61 | T3 timeout; timeout while waiting for SABM during an incoming call                   | 4      |
| 7-62 | T1 timeout x N2; timeout while waiting for UA after sending SABM                     | 5      |
| 7-63 | T1 timeout x N2; timeout while waiting for a response to a transmitted S frame (P=1) | 5      |
| 7-64 | T1 timeout x N2; timeout while waiting for SABM or DISC after sending FRMR           | 5      |
| 7-65 | T1 timeout x N2; timeout while waiting for a response to DISC                        | 5      |
| 7-66 | RNR x N2 (other end busy, RCB counter error)   | 5      |
| 7-67 | Invalid (Ad) frame received  | 5      |
| 7-68 | Invalid short frame received   | 5      |
| 7-69 | Link reset error   | 5      |
| 7-70 | FRMR received  | 5      |
| 7-71 | Non-standard (Cn) frame received   | 5      |
| 7-72 | An S or U frame having an information field was received                             | 5      |
| 7-73 | A frame longer than the maximum N1 length was received                               | 5      |
| 7-74 | An S or I frame having an N(R) error was received                                    | 5      |
| 7-75 | CRC error  | 3      |



## 1.6. B-CANNEL NETWORK LAYER

| Code | Probable Cause  | Action |
|------|---|--------|
| 7-80 | A packet having an abnormal GFI was received  | 6      |
| 7-81 | A packet was received that had a logical channel number different from the logical channel being used for the communication | 6      |
| 7-82 | A packet containing a format error was received   | 6      |
| 7-83 | A packet containing an LI error was received  | 7      |
| 7-84 | A CN packet was received that had a PID different from 02   | 7      |
| 7-85 | Unsupported packet type received  | 7      |
| 7-86 | Abnormal or unsupported facility received   | 7      |
| 7-87 | P(s) sequence number error  | 6      |
| 7-88 | P(r) sequence number error  | 6      |
| 7-89 | A reset using S:RQ or R:RI occurred   | 6      |
| 7-90 | A restart using S:RQ or R:SI occurred   | 6      |
| 7-91 | Call set-up error; in reply to S:CR, R:CI was received to indicate rejection of the call                                    | 7      |
| 7-92 | T20 timeout; timeout while waiting for an SF packet   | 6      |
| 7-93 | T21 timeout; timeout while waiting for a CC packet  | 6      |
| 7-94 | T22 timeout; timeout while waiting for an RF packet   | 6      |
| 7-95 | T23 timeout; timeout while waiting for a CF packet  | 6      |
| 7-96 | T10 timeout; timeout while waiting for the first frame  | 6      |

## 1.7. TRANSPORT LAYER

| Code | Probable Cause  | Action |
|------|---|--------|
| 8-00 | Invalid block received  | 8      |
| 8-01 | TCC block received  | 8      |
| 8-02 | TBR block received  | 8      |
| 8-05 | TCR block; block format error   | 8      |
| 8-06 | TCR block; block size parameter LI error  | 8      |
| 8-07 | TCR block; extended addressing LI error   | 8      |
| 8-08 | TCR block; block size length error  | 8      |
| 8-10 | TCA block; block format error   | 8      |
| 8-11 | TCA block; Tx origin reference data in TCR disagreed with the address reference data in TCA | 8      |
| 8-12 | TCA block; octet 7 did not equal 0  | 8      |
| 8-13 | TCA block; extended addressing LI error   | 8      |
| 8-14 | TCA block; block size exceeded that set by TCR  | 8      |
| 8-15 | TCA block; block size parameter LI error  | 8      |
| 8-20 | TDT block; block format error   | 8      |
| 8-21 | TDT block; octet 3 did not equal either 00 or 80(H)   | 8      |
| 8-22 | TDT block; the end indicator was "Continue" even though there was no field data             | 8      |
| 8-23 | TDT block; an end block with no field data was received after an end indicator of "End"     | 8      |
| 8-26 | Timeout during state 0.2  | 8      |
| 8-27 | Timeout during state 1.1  | 8      |

| Code | Probable Cause           | Action |
|------|--------------------------|--------|
| 8-28 | Timeout during state 0.3 | 8      |

## 1.8. SESSION LAYER

| Code | Probable Cause  | Action |
|------|---|--------|
| 8-30 | Invalid frame received  | 8      |
| 8-31 | RSSN received   | 8      |
| 8-32 | CSA received  | 8      |
| 8-34 | Calling terminal identification error in CSS  | 8      |
| 8-35 | Date and time error in CSS  | 8      |
| 8-36 | Window size error in CSS  | 8      |
| 8-37 | Service identification error in CSS   | 8      |
| 8-38 | Session user data error in CSS  | 8      |
| 8-39 | CSS rejected (new session rejected)   | 8      |
| 8-40 | Called terminal identification error in RSSP  | 8      |
| 8-41 | Date and time error in RSSP   | 8      |
| 8-42 | Date and time in RSSP was not the same as that in CSS   | 8      |
| 8-43 | Window size error in RSSP   | 8      |
| 8-44 | Service identification error in RSSP  | 8      |
| 8-45 | Session user data error in RSSP   | 8      |
| 8-47 | Message synchronization error inside the CCU  | 8      |
| 8-48 | Document task busy  | 8      |
| 8-50 | Ti timeout; non-communication surveillance timer (T.62)   | 8      |
| 8-51 | T2 timeout; timeout while waiting for a response (T.62)   | 8      |
| 8-52 | T3 timeout; CSA timer timeout (T.62)  | 8      |
| 8-53 | G4 board load timer timeout; calling side waited too long for a new session                       | 8      |
| 8-54 | G4 board load timer timeout; calling side waited too long for transport probability               | 8      |
| 8-55 | G4 board load timer timeout; called side waited too long for S:RSSP                               | 8      |
| 8-56 | G4 board load timer timeout; document transmission surveillance timer timeout                     | 8      |
| 8-57 | G4 board load timer timeout; timeout while waiting for a user abort request after a provider fail | 8      |

## 1.9. DOCUMENT LAYER

| Code | Probable Cause   | Action |
|------|--|--------|
| 8-60 | T.62 coding format error (LI error)  | 8      |
| 8-61 | A mandatory PI was absent, or the LI for a mandatory PI was 0                                  | 8      |
| 8-62 | Calling/called terminal identification LI was different from that specified by F.184 (LI = 24) | 8      |
| 8-63 | The LI for session user data exceeded the maximum value (512)                                  | 8      |
| 8-64 | The LI for CDUI was not 0  | 8      |
| 8-65 | Checkpoint and document reference numbers LI error, or they were not in T.61 (ASCII) coding    | 8      |
| 8-66 | The checkpoint reference number differed from the expected value                               | 8      |

| Code | Probable Cause  | Action |
|------|---|--------|
| 8-70 | RDGR received   | 8      |
| 8-71 | A non-standard PDU was received while in calling mode   | 8      |
| 8-72 | A non-standard PDU was received while in called mode    | 8      |
| 8-73 | Abnormal PDU received while in calling state ds1        | 8      |
| 8-74 | 15 consecutive CDCL signals received                    | 8      |
| 8-75 | Session window size control error (size not equal to 0) | 8      |
| 8-76 | Internal error  | 8      |

## 1.10. PRESENTATION LAYER

| Code | Probable Cause   | Action |
|------|--|--------|
| 8-80 | X.209 coding error in session user data (LI error)   | 8      |
| 8-81 | PV error in session user data  | 8      |
| 8-82 | PI error in session user data  | 8      |
| 8-83 | The capabilities in the session user data of CDS/CDC were not the same as those in RDCLP                               | 8      |
| 8-84 | X.209 coding error in the DP (LI error)  | 8      |
| 8-85 | X.209 coding error in the SLD (document descriptor/page descriptor) (LI error)   | 8      |
| 8-86 | SLD object type absent   | 8      |
| 8-87 | PI error in the SLD (document descriptor/page descriptor)  | 8      |
| 8-88 | The capabilities in the SLD (document descriptor/page descriptor) are duplicated or are not the same as those in RDCLP | 8      |
| 8-89 | No document descriptor at the start of the document  | 8      |
| 8-90 | No page descriptor at the start of the page  | 8      |
| 8-91 | Page descriptor PV error   | 8      |
| 8-92 | X.209 coding error in the TU (LI error)  | 8      |
| 8-93 | The TU was absent  | 8      |
| 8-94 | PV error in the TU   | 8      |
| 8-95 | TI error   | 8      |
| 8-96 | X.209 coding nest level > 8, or an LI form error   | 8      |
| 8-97 | CDPB/CDE received while TU/TI not yet completed, or an unexpected PDU was received while analyzing an SLD              | 8      |

## 2. G4CCU STATUS CODES

---

The display of G4CCU status codes is affected by the Real Time Display On/off setting (G4 Parameter Switch E, bit 0).

- If Real Time Display is off (the bit is 0; this is the default setting), there is no indication on the operation panel.
- If Real Time Display is on (the bit is 1), the codes are fully displayed on the operation panel.

The codes are defined in the following pages.

### 2.1. LAYER 1 (PHYSICAL LAYER)

| Code (H) | Status         | Code (H) | Status        |
|----------|----------------|----------|---------------|
| 10       | Ready          | E0       | R: [DISC]     |
| 01       | S: [SETUP]     | E1       | S: [REL]      |
| 02       | R: [CALL_PROC] | E3       | R: [REL_COMP] |
| 03       | R: [CONN]      | E4       | R: [STAT]     |
| 04       | S: [CONN_ACK]  | E5       | R: [STAT_ENQ] |
| 05       | R: [SETUP_ACK] | F0       | S: [DISC]     |
| 06       | R: [ALERT]     | F1       | R: [REL]      |
| 11       | R: [SETUP]     | F2       | S: [REL_COMP] |
| 12       | S: [CALL_PROC] | F3       | S: [STAT]     |
| 13       | S: [CONN]      |          |               |
| 14       | R: [CONN_ACK]  |          |               |

### 2.2. LAYER 2 (LINK LAYER)

| Code (H) | Status                | Code (H) | Status              |
|----------|-----------------------|----------|---------------------|
| 20       | S: SABM, or R: SABM   | D0       | S: DISC, or R: DISC |
| 21       | S: UA, or R: UA       | D1       | S: DM, or R: DM     |
| 22       | S: FRMR, or R: FRMR   |          |                     |
| 28       | S: SABME, or R: SABME |          |                     |

## 2.3. NETWORK LAYER (LAYER 3)

| Code (H) | Status | Code (H) | Status  |
|----------|--------|----------|---------|
| 30       | S: CR  | C2       | S: SQ   |
| 31       | R: CC  | C3       | R: SF   |
| 38       | R: CN  | CA       | R: SI   |
| 39       | S: CA  | CB       | S: SF   |
| 32       | S: GF  | C4       | S: RQ   |
| 3A       | R: GQ  | C5       | R: RF   |
| 3B       | R: GF  | CC       | R: RI   |
| C0       | S: CQ  | CD       | S: RF   |
| C1       | R: CF  | C6       | R: IT   |
| C8       | R: CI  | C7       | R: IF   |
| C9       | S: CF  | CE       | R: DIAG |

## 2.4. TRANSPORT LAYER (LAYER 4)

| Code (H) | Status            | Code (H) | Status            |
|----------|-------------------|----------|-------------------|
| 40       | S: TCR, or R: TCR | 42       | S: TBR, or R: TBR |
| 41       | S: TCA, or R: TCA | 43       | S: TCC or R: TCC  |

## 2.5. SESSION LAYER, SESSION CONTROL LAYER (LAYER 5)

| Code (H) | Status                | Code (H) | Status              |
|----------|-----------------------|----------|---------------------|
| 50       | S: CSS, or R: CSS     | 56       | S: RSUI, or R: RSUI |
| 51       | S: RSSP, or R: RSSP   | A0       | S: CSA, or R: CSA   |
| 52       | S: RSSN, or R: RSSN   | A1       | S: RSAP, or R: RSAP |
| 53       | S: CCCC, or R: CCCC   | A2       | S: CSE, or R: CSE   |
| 54       | S: RSCCP, or R: RSCCP | A3       | S: RSEP, or R: RSEP |

## 2.6. SESSION LAYER, DOCUMENT CONTROL LAYER (LAYER 5)

| Code (H) | Status  | Code (H) | Status                |
|----------|---|----------|-----------------------|
| 60       | S: CDCL, or R: CDCL   | 90       | S: CDE, or R: CDE     |
| 61       | S: RDCLP, or R: RDCLP   | 91       | S: RDEP, or R: RDEP   |
| 62       | S: CDS, or R: CDS   | 92       | S: CDD, or R: CDD     |
| 63       | S: CDC, or R: CDC   | 93       | S: RDDP, or R: RDDP   |
| 64       | S: CDPB, or R: CDPB   | 94       | S: CDR, or R: CDR     |
| 65       | S: RDPBP, or R: RDPBP   | 95       | S: RDRP, or R: RDRP   |
| 70       | S: CDUI, or R: CDUI (Data phase - layer 6 and facsimile data) | 96       | S: RDGR, or R: RDGR   |
|          |   | 97       | S: RDPBN, or R: RDPBN |

### 3. LEDs

There are six LEDs on the G4 Interface board, as shown below.

|       |       |       |       |
|-------|-------|-------|-------|
|       |       | LED 5 | LED 6 |
| LED 1 | LED 2 | LED 3 | LED 4 |

These LEDs give the following information about the status of the machine.

O = ON, -- = OFF

**Initial Settings**

Power-up/Reset

|    |    |    |    |
|----|----|----|----|
|    |    | O  | O  |
| -- | -- | -- | -- |

Initial setting request from FCU

|    |    |    |    |
|----|----|----|----|
|    |    | -- | O  |
| -- | -- | -- | -- |

Initial setting confirmation to FCU

|    |    |    |    |
|----|----|----|----|
|    |    | -- | -- |
| -- | -- | -- | -- |

**Communication**

Layer 1 activated

|   |    |    |    |
|---|----|----|----|
|   |    | -- | -- |
| O | -- | -- | -- |

Layer 2 set

|   |   |    |    |
|---|---|----|----|
|   |   | -- | -- |
| O | O | -- | -- |

B channel connected (ISDN G4)

|   |   |    |    |
|---|---|----|----|
|   |   | -- | -- |
| O | O | O  | -- |

B channel connected (ISDN G3)

|   |   |    |    |
|---|---|----|----|
|   |   | -- | -- |
| O | O | -- | O  |

B channel released

|   |   |    |    |
|---|---|----|----|
|   |   | -- | -- |
| O | O | -- | -- |

Layer 2 released

|   |    |    |    |
|---|----|----|----|
|   |    | -- | -- |
| O | -- | -- | -- |

Layer 1 deactivated

|    |    |    |    |
|----|----|----|----|
|    |    | -- | -- |
| -- | -- | -- | -- |

The following will be displayed if bit 1 of G4 parameter switch E is at 1.

B channel: send I frame (A blinks at this time if bit 1 of G4 parameter switch E is at 1)

|   |   |    |    |
|---|---|----|----|
|   |   | -- | A  |
| O | O | O  | -- |

B channel: receive I frame (B blinks at this time if bit 1 of G4 parameter switch E is at 1)

|   |   |   |    |
|---|---|---|----|
|   |   | B | -- |
| O | O | O | -- |

**Note:** At the start and end of communication, both A and B will blink.

## 4. BACK-TO-BACK TEST

To make a back-to-back test, you need:

- Two machines (both of them must have CiG4 board)
- Cross rosette

The procedure is as follows.

1. Switch off the machines
2. Connect two machines back-to-back using the cross rosette as follows.

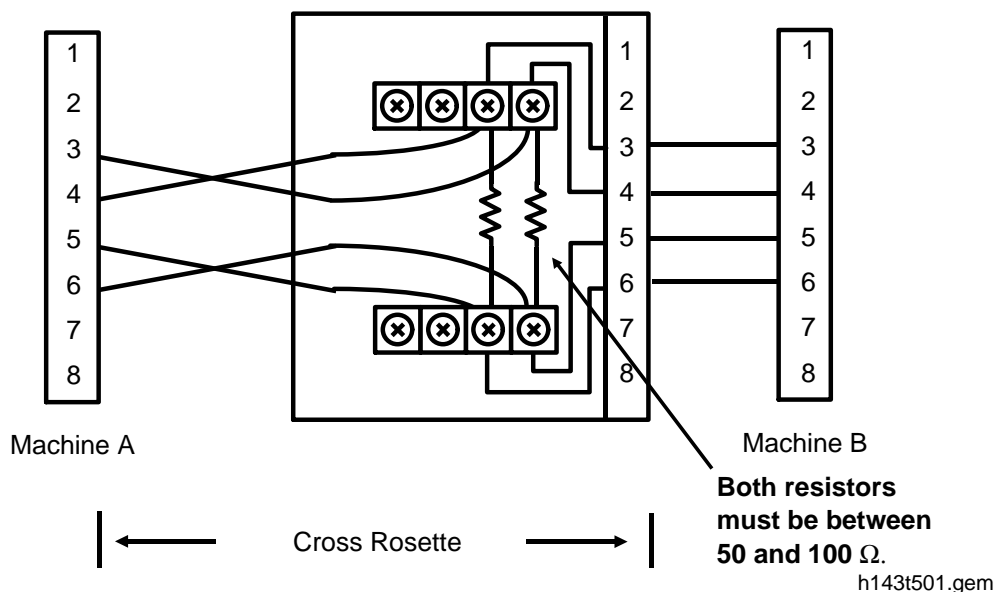

3. Make the following bit switch adjustments:

- In the machine acting in NT mode, set bits 0 and 1 of G4 parameter switch 0D to 1.
- In the machine acting in TE mode, set bit 0 of G4 parameter switch 0D to 0 and bit 1 to 1.

4. Reset the machine by switching it off, waiting a few seconds, then switching back on.

5. Place a document in one of the machines, dial a number, then press Start.

6. After you have finished the test, set bits 0 and 1 of G4 parameter switch 0D back to 0. then reset the machine.

**Note:** The following cannot be tested using this procedure:

- ISDN G3 communication
- P to M

# **APPENDIX**



July 31st, 1996

# APPENDIX A

# 1. D-Channel Layer 1 Dump List

---

## 1.1. How to Print the Dump List

Use this function to print the D-ch. Layer 1 dump list.

1. After entering the service mode,  
press  , then
2. Input the addresses 03B000 to 03B1FF:  
Input 0 - 3 - B - 0 - 0 - 3 - B - 1 -

### List Sample

```
* * * G4 CCU MEMORY DUMP LIST (SEP. 25.1995 4.05PM) * * *
-----
03B000  00 00 00 F2  10 1E 00 F3  01 1C 64 F4  10 12 00 F5
03B010  11 22 00 F6  10 36 00 F7  02 00 08 F7  20 A6 08 F7
03B020  03 81 00 F7  07 34 60 F7  10 32 00 F7  02 00 03 F7
03B030  20 29 03 F7  02 00 18 F7  20 A9 04 F7  20 AB 0B F7
03B040  02 00 04 F7  20 AB 0C F7  02 00 04 F7  02 00 08 F7
03B050  20 A9 04 F7  20 AB 0E F7  02 00 04 F7  02 00 08 F7
03B060  20 A9 04 F7  20 00 03 F7  20 29 03 F7  10 02 7C F3
03B070  10 3E 40 F3  10 1E 00 F3  FF FF FF FF  00 00 FF FF
03B080  FF FF 00 00  00 00 FF FF  FF FF 00 00  00 00 FF FF
03B090  FF FF 00 00  00 00 FF FF -----
      |
      |
      |
```

H143X501.wmf

Refer to "How to Read the Dump List" later in this chapter.

## 1.2. How to Read the Dump List

### 1.2.1. Data Format

The machine logs the details of layer 1 communication whenever an event has taken place. The event can be either a request from the machine, a request from the DSU, a transmission of a signal, or a reception of a signal.

Each log consists of 4 bytes. The first byte indicates the type of event, the second and the third bytes for optional data, which depends on the type of event, and the fourth byte indicates the layer 1 status. The following table explains all types of data formats.

| 1st byte                                      | 2nd byte           | 3rd byte  | 4th byte  |
|---|--------------------|---|---|
| <b>00(H)</b> : TE mode initialization request | <b>00(H)</b>       | <b>00(H)</b>                                      | Layer 1 status  |
| <b>01(H)</b> : Layer 1 activation request     | See note 1         | See note 2  | TE mode<br><b>F1(H)</b> : F1 status<br><b>F2(H)</b> : F2 status<br><b>F3(H)</b> : F3 status<br><b>F4(H)</b> : F4 status<br><b>F5(H)</b> : F5 status<br><b>F6(H)</b> : F6 status<br><b>F7(H)</b> : F7 status<br><b>F8(H)</b> : F8 status |
| <b>10(H)</b> : Layer 1 status has changed     |                    |   |   |
| <b>02(H)</b> : Frame transmission request     | <b>00(H)</b>       | Number of transmitted data bytes (Max. 255 bytes) | NT mode<br><b>C1(H)</b> : G1 status<br><b>C2(H)</b> : G2 status<br><b>C3(H)</b> : G3 status<br><b>C4(H)</b> : G4 status   |
| <b>20(H)</b> : Frame reception indication     | See note 3         | Number of received data bytes (Max. 255 bytes)    |   |
| <b>03(H)</b> : TEI assignment request         | Assigned TEI value | 00(H)   |   |
| <b>04(H)</b> : Layer 1 de-activation request  | See note 4         | See note 2  |   |
| <b>05(H)</b> : Loop back mode request         | <b>00(H)</b>       | <b>00(H)</b>                                      | Refer to the "Layer 1 Activation/Deactivation Procedure" later in this chapter.   |
| <b>06(H)</b> : NT mode initialization request | <b>00(H)</b>       | <b>00(H)</b>                                      |   |
| <b>EE(H)</b> : Communication error            | See note 5         | <b>00(H)</b>                                      |   |

The data "FF FF FF FF" indicates the end of the data.

## Notes

### 1. Status Register Value

| Data (Hex) | Description                      |
|------------|----------------------------------|
| 1E or 1C   | Deactivated or standby           |
| 02 or 00   | INFO0 signal received            |
| 0E or 0C   | Not connected                    |
| 1A or 18   | Error status                     |
| 12 or 10   | Non-synchronized signal received |
| 22 or 20   | INFO2 signal received            |
| 32 or 30   | Priority high                    |
| 36 or 34   | Priority low                     |
| 3E or 3C   | Terminated                       |

### 2. Command Register Value

| Data (Hex) | Description                             |
|------------|---|
| 00         | No command requested                    |
| 40         | Standby request                         |
| 44         | Reset request                           |
| 60         | Priority change request (High priority) |
| 64         | Priority change request (Low priority)  |
| 7C         | Termination request                     |

### 3. Received Frame Status Register

Bit 7 - Not used

Bit 6 - 0: Normal, 1: Received data overflow

Bit 5 - 0: Normal, 1: CRC error

Bit 4 - 0: Normal, 1: Received frame aborted

Bits 3 to 0: Not used

### 4. Interrupt Status Register

Bit 7 - 0: Normal, 1: Frame received

Bit 6 - 0: Normal, 1: Receive buffer full

Bit 5 - Not used

Bit 4 - 0: Normal, 1: Transmission buffer full

Bit 3 - Not used

Bit 2 - 0: Normal, 1: Layer 1 status has changed

Bit 1 - Not used

Bit 0 - 0: Normal, 1: Communication error

### 5. Communication Error Status Register

Bit 7 - 0: Normal, 1: Frame resend

Bit 6 - 0: Normal, 1: Transmission underrun

Bit 5 - Not used

Bit 4 - 0: Normal, 1: Transmission pool overflow

Bits 3 to 0 - Not used

### 1.2.2. Reading the Sample Dump List

#### Line #1

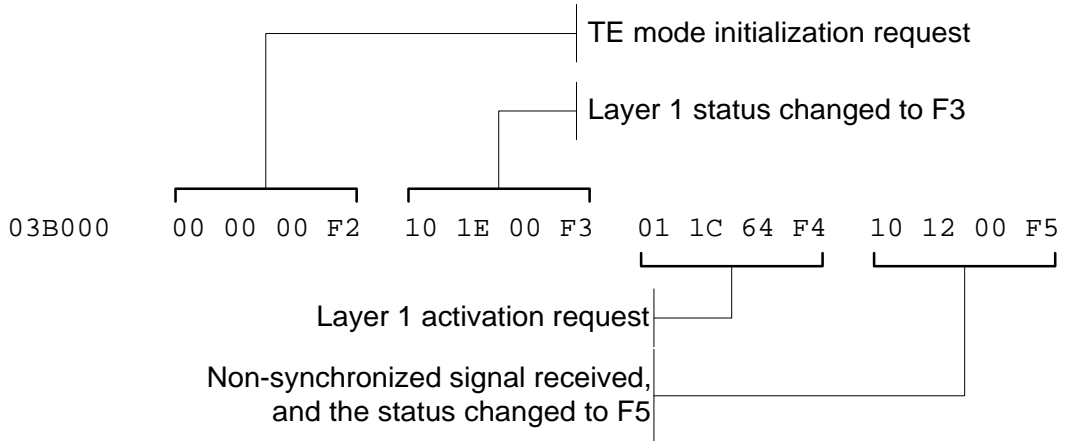

H143X502.wmf

#### Line #2

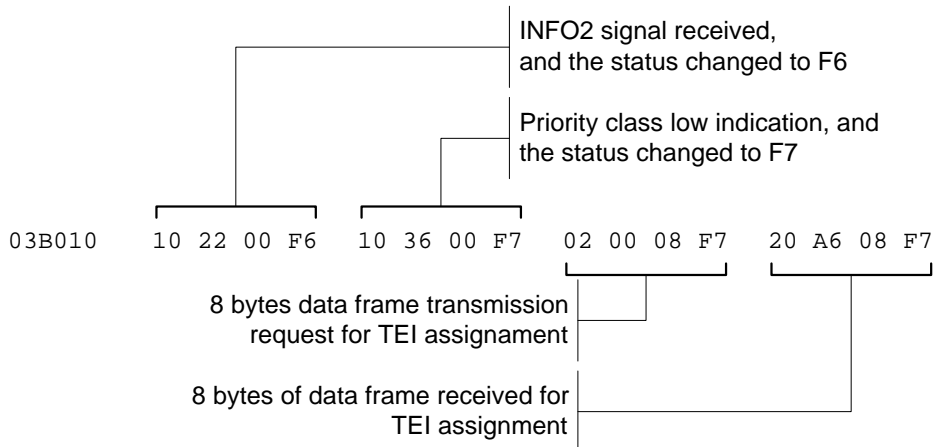

H143X503.wmf

#### Line #3

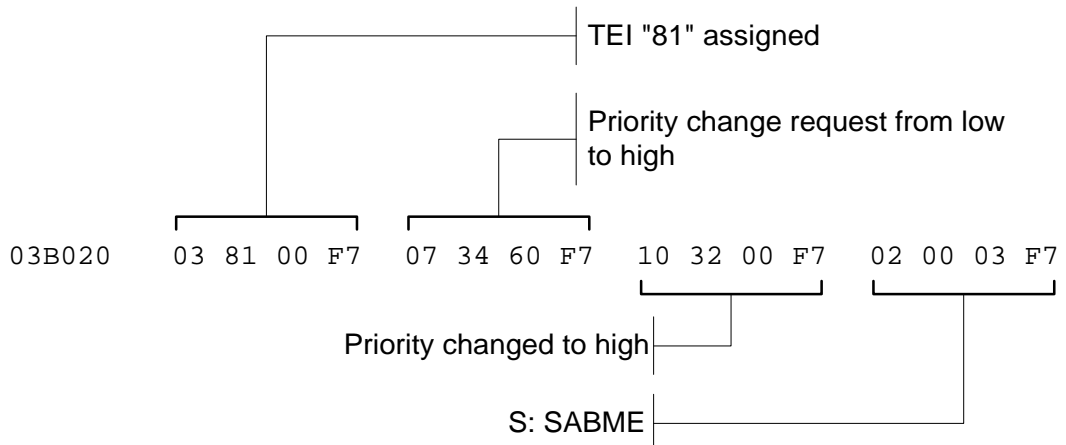

H143X504.wmf

Line #4

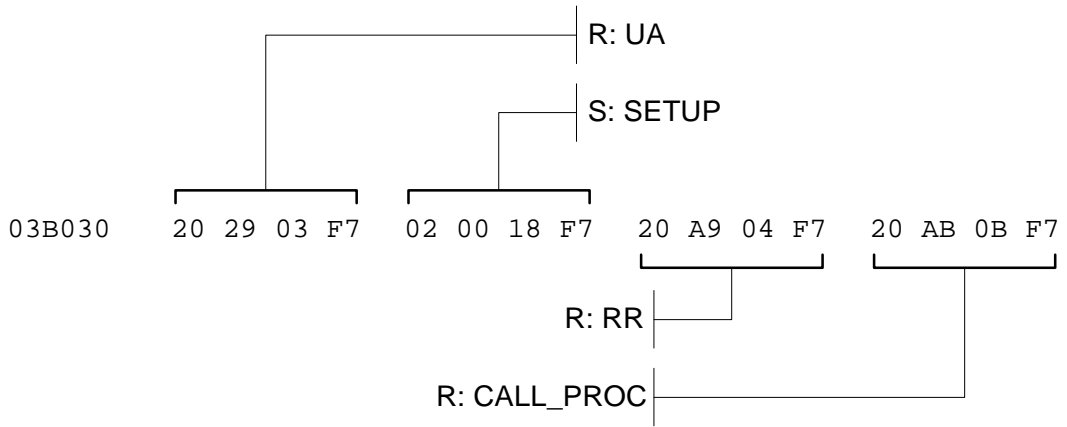

H143X505.wmf

Line #5

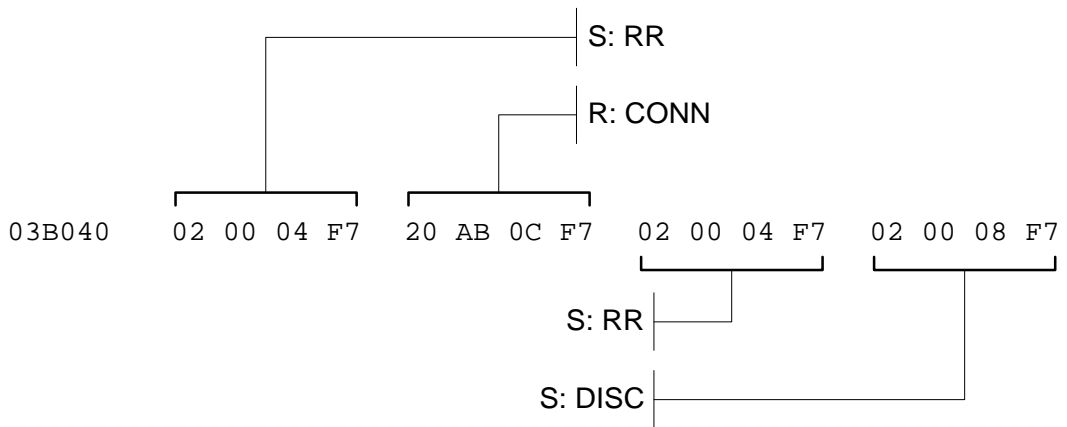

H143X506.wmf

Line #6

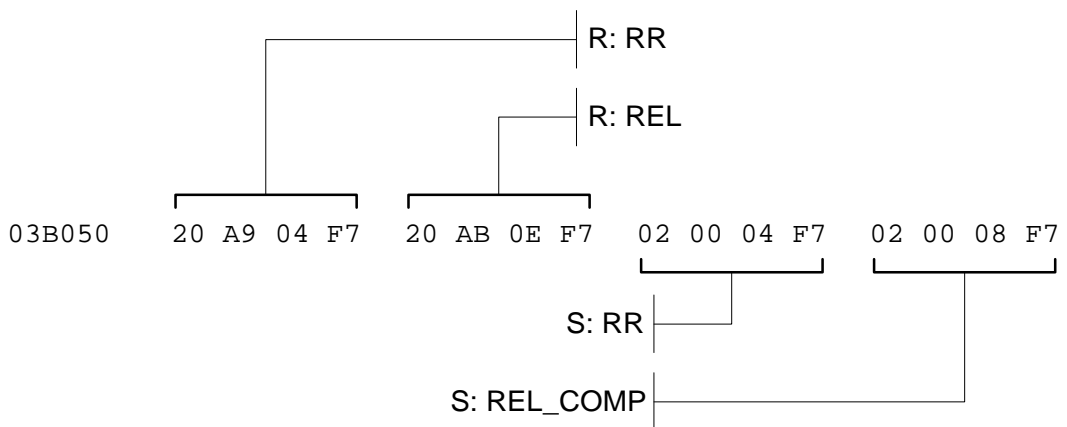

H143X507.wmf

Line #7

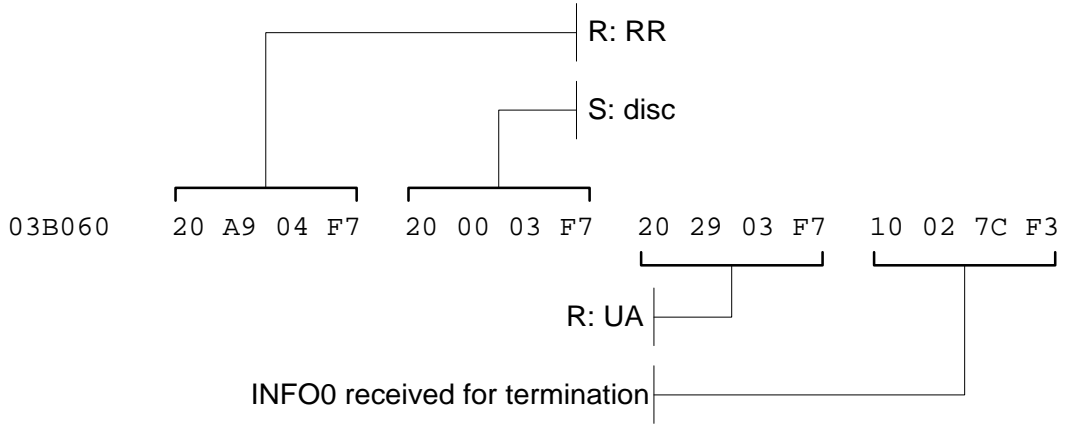

H143X508.wmf

Line #8

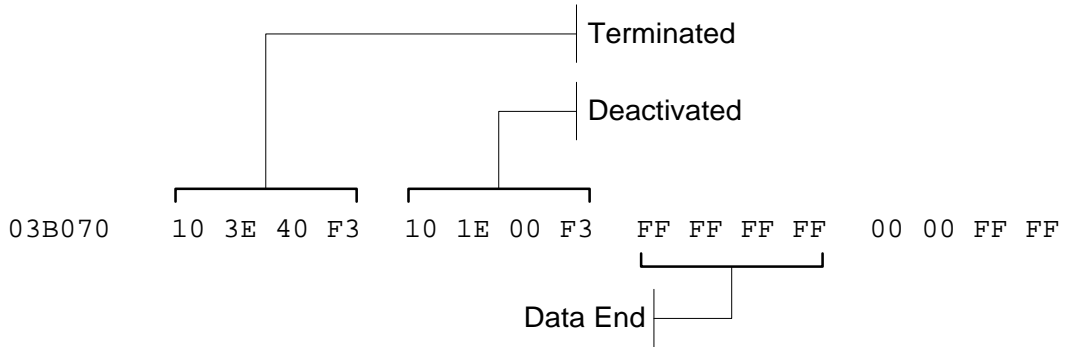

H143X509.wmf

### 1.2.3. Layer 1 Status

The ITU-T I.430 recommendation (the basic user-network interface - Layer 1 specification) specifies layer 1 activation/deactivation procedures.

Before understanding the procedures, the status and INFO signals should be noted.

#### TE (Terminal Equipment) Status

| Status | Description  |
|--------|--|
| F1     | TE is turned off.  |
| F2     | TE is turned on, but no signal is exchanged.                                 |
| F3     | TE is stopped. No signal is exchanged between TE and NT.                     |
| F4     | TE is waiting for the response to INFO1 signal from NT.                      |
| F5     | TE is checking if the signal from the NT is INFO2 or INFO4.                  |
| F6     | TE is waiting for signals from NT after receiving INFO2 signal.              |
| F7     | TE and NT are in synchronized condition.                                     |
| F8     | TE has failed to synchronize to NT, and waiting for the stop request from NT |

#### NT (Network Termination) Status

| Status | Description                              |
|--------|--|
| G1     | NT is stopped.                           |
| G2     | NT is sending INFO2 signal.              |
| G3     | TE and NT are in synchronized condition. |
| G4     | NT is terminating itself.                |

#### INFO Signals

| NT to TE Direction |  | TE to NT direction |  |
|--------------------|--|--------------------|--|
| INFO0              | No signal<br>(11111111...)   | INFO0              | No signal<br>(11111111...)   |
| INFO2              | Activation signal in<br>synchronized condition<br>(B=0, D=0, E=0, A=0) | INFO1              | Activation signal in<br>non-synchronized condition<br>(+0-0111111+0-0) |
| INFO4              | Synchronized frame   | INFO3              | Synchronized frame   |



### 1. Activation Procedure from the TE

In idle "F3" status, the TE send the INFO1 signal to the NT and changes to "F4" status. The NT then changes to "G2" status and sends INFO2 signal to the TE.

The TE changes to "F5" status and stops sending signals to synchronize itself to the signal from the NT.

After the TE has synchronized to the signal, it sends INFO3 signal to the NT and changes to the "F6" status.

The NT then changes to "G3" status and sends INFO4 signal back to the TE to inform that a physical link has been established.

The timers T1, T2 and T3 are used to reset the TE or NT if a correct response has not received before the timers expire.

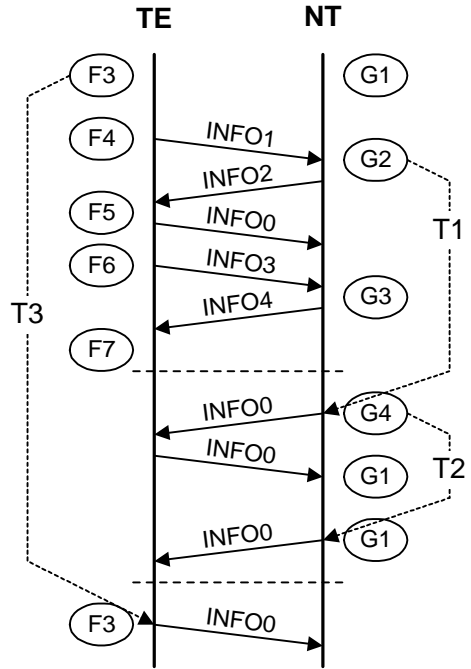

H143X510.wmf

### 2. Activation Procedure from the NT

The procedure starts from the NT by sending INFO2 signal to the TE.

After the TE has synchronized to the signal, it sends INFO3 signal to the NT and changes to the "F6" status.

The NT then changes to "G3" status and sends INFO4 signal back to the TE to inform that a physical link has been established.

The timers T1 and T2 are used to reset the NT if a correct response has not received before the timers expire.

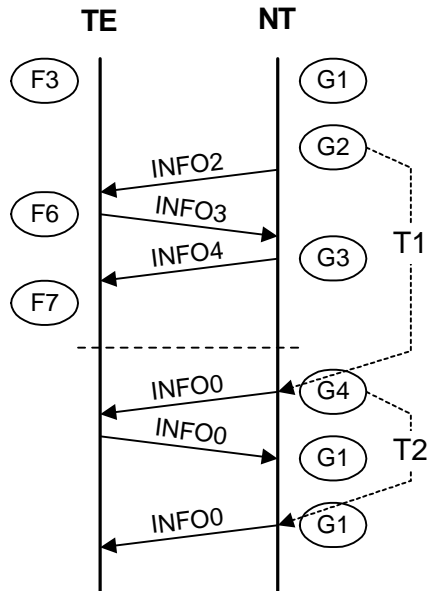

H143X511.wmf

### 3. Termination Procedure from the NT

The termination procedure starts from synchronized status ("F7" status for the TE and "G3" status for the NT).

To terminate the physical connection, the NT just stops sending signals and changes to "G1" status. (The INFO0 signal means no signal is sent from the NT.) Then, the TE also stops sending signals and changes to "F3" status.

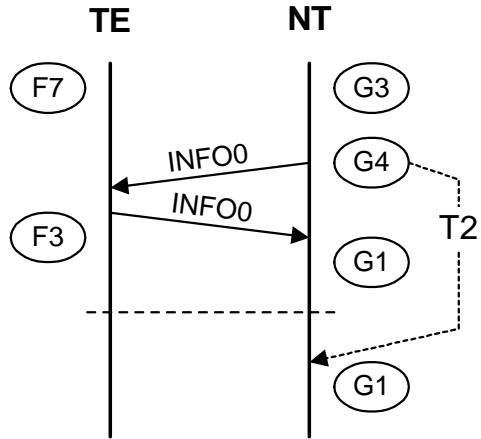

H143X512.wmf

July 31st, 1996

# APPENDIX B

# 1. G4 Parameter Locations

## 1.1. Initial Programming Items Comparison List

**Note:** The model "CGO" is only for the US and Taiwan markets.

| Item                              | CFO        | LHO/CGO    | FX4        | Type 250   |
|-----------------------------------|------------|------------|------------|------------|
| Country code                      | U: F-61    | U: F-61    |            |            |
| Own analog number                 | U: F-61    | U: F-61    | U: F-61    | U: Key Op. |
| Area code prefix                  | U: F-61    | U: F-61    |            |            |
| Own ISDN-G4 number                | U: F-61    | U: F-61    | U: F-61    | U: Key Op. |
| Own ISDN-G3 number                | U: F-61    | U: F-61    | U: F-61    | U: Key Op. |
| Next transfer station             | U: F-61    | U: F-61    |            |            |
| G4 internal switches              | S: F-18-01 | S: F-18-01 | S: F-17-01 | S: F-01-6  |
| G4 parameter switches             | S: F-18-02 | S: F-18-02 | S: F-17-02 | S: F-01-7  |
| Data network international prefix | S: F-18-03 | S: F-18-03 |            |            |
| ISDN international prefix         | S: F-18-04 | S: F-18-04 | S: F-17-03 | S: F-12-1  |
| G4 subscriber number 1            | S: F-18-05 | S: F-18-05 | S: F-17-04 | S: F-12-2  |
| G4 subscriber number 2            | S: F-18-06 | S: F-18-06 | S: F-17-05 | S: F-12-3  |
| IG3 subscriber number 1           | S: F-18-07 | S: F-18-07 | S: F-17-06 | S: F-12-4  |
| IG3 subscriber number 2           | S: F-18-08 | S: F-18-08 | S: F-17-07 | S: F-12-5  |
| Internal Access Unit 1            | S: F-18-09 | S: F-18-09 |            |            |
| Internal Access Unit 2            | S: F-18-10 | S: F-18-10 |            |            |
| G4 subaddress                     | S: F-18-11 | S: F-18-11 | S: F-17-08 | S: F-12-6  |
| IG3 subaddress                    | S: F-18-12 | S: F-18-12 | S: F-17-09 | S: F-12-7  |
| G4 terminal ID                    | S: F-18-13 | S: F-18-13 | U: F-61    | U: Key Op. |
| IG3 CSI                           | S: F-18-14 | S: F-18-14 | U: F-61    | U: Key Op. |
| G4 dump 1 (RAM dump)              | S: F-18-15 | S: F-18-15 | S: F-17-10 | S: F-06-4  |
| G4 dump 2 (Protocol dump)         | S: F-18-16 | S: F-18-16 | S: F-17-11 | S: F-05-2  |
| G4 parameter list                 | S: F-18-17 | S: F-18-17 | S: F-17-12 | S: F-02-2  |
| Service level password            | 1991       | 1991       | 1995       | 1988-Start |

**U:** User level function

**S:** Service level function

**Key Op.:** Key operator mode (User Tools - Fax - 6 - #)

## 1.2. Switch Locations Comparison List

**Note:** The model "CGO" is only for the US and Taiwan markets.

### 1. Communication Parameter Display

| Model        | Switch Location         | Setting       |
|--------------|-------------------------|---------------|
| CFO          | Bit switch 00, bit 7    | 0: Off, 1: On |
| LHO/CGO      | Bit switch 00, bit 7    | 0: Off, 1: On |
| FX4/Type 250 | System switch 00, bit 5 | 0: Off, 1: On |

### 2. Default Communication Mode

| Model        | Switch Location         | Setting      |
|--------------|-------------------------|--------------|
| CFO          | 000153(H), bit 2        | 0: G3, 1: G4 |
| LHO/CGO      | 080053(H), bit 2        | 0: G3, 1: G4 |
| FX4/Type 250 | System switch 0A, bit 0 | 0: G3, 1: G4 |

### 3. Network Used for G3 Transmission

| Model        | Switch Location         | Setting          |
|--------------|-------------------------|------------------|
| CFO          | 000153(H), bit 3        | 0: PSTN, 1: ISDN |
| LHO/CGO      | 080053(H), bit 3        | 0: PSTN, 1: ISDN |
| FX4/Type 250 | System switch 0A, bit 6 | 0: PSTN, 1: ISDN |

### 4. Network Used for G3 transmission in G4-to-G3 Fallback

| Model        | Switch Location         | Setting          |
|--------------|-------------------------|------------------|
| CFO          | 000153(H), bit 3        | 0: PSTN, 1: ISDN |
| LHO/CGO      | 080053(H), bit 3        | 0: PSTN, 1: ISDN |
| FX4/Type 250 | System switch 0A, bit 7 | 0: PSTN, 1: ISDN |

### 5. Automatic G4-to-G3 Fallback

| Model        | Switch Location                | Setting                 |
|--------------|--------------------------------|-------------------------|
| CFO          | 00015C(H), bit 0               | 0: Enabled, 1: Disabled |
| LHO/CGO      | 08005C(H), bit 0               | 0: Enabled, 1: Disabled |
| FX4/Type 250 | Communication switch 07, bit 0 | 0: Enabled, 1: Disabled |

## 6. Specified Two Step Transfer

| Model        | Switch Location        | Setting                 |
|--------------|------------------------|-------------------------|
| CFO          | 00015C(H), bit 1       | 0: Disabled, 1: Enabled |
| LHO/CGO      | 08005C(H), bit 1       | 0: Disabled, 1: Enabled |
| FX4/Type 250 | Function not available |                         |

## 7. Cable Equalizer for ISDN Transmission

| Model        | Switch Location             | Setting      |              |                |
|--------------|-----------------------------|--------------|--------------|----------------|
| CFO          | Bit switch 08, bits 6 and 7 | <b>Bit 7</b> | <b>Bit 6</b> | <b>Setting</b> |
| LHO/CGO      |                             | 0            | 0            | None           |
|              |                             | 0            | 1            | Low            |
|              |                             | 1            | 0            | Medium         |
|              | 1                           | 1            | High         |                |
| FX4/Type 250 | G3 switch 09, bits 0 and 1  | <b>Bit 1</b> | <b>Bit 0</b> | <b>Setting</b> |
|              |                             | 0            | 0            | None           |
|              |                             | 0            | 1            | Low            |
|              |                             | 1            | 0            | Medium         |
|              |                             | 1            | 1            | High           |

## 8. Cable Equalizer for ISDN Reception

| Model        | Switch Location             | Setting      |              |                |
|--------------|-----------------------------|--------------|--------------|----------------|
| CFO          | Bit switch 0A, bits 6 and 7 | <b>Bit 7</b> | <b>Bit 6</b> | <b>Setting</b> |
| LHO/CGO      |                             | 0            | 0            | None           |
|              |                             | 0            | 1            | Low            |
|              |                             | 1            | 0            | Medium         |
|              | 1                           | 1            | High         |                |
| FX4/Type 250 | G3 switch 09, bits 2 and 3  | <b>Bit 3</b> | <b>Bit 2</b> | <b>Setting</b> |
|              |                             | 0            | 0            | None           |
|              |                             | 0            | 1            | Low            |
|              |                             | 1            | 0            | Medium         |
|              |                             | 1            | 1            | High           |

July 31st, 1996

# APPENDIX C

# 1. Conditions for Receiving a Call

**BC:** Bearer Capability

**HLC:** Higher Layer Compatibility

**SA:** Subaddress

| Tx Terminal | Setup   |       |                       | Response     | Condition   |
|-------------|---------|-------|-----------------------|--------------|---|
|             | BC      | HLC   | Called No./ Called SA |              |   |
| G4 Fax      | Digital | G4    | Not included          | G4 reception |   |
|             | Digital | G4    | Included              | G4 reception | If called no. and called subaddress match the G4 subscriber no.         |
|             |         |       |                       | No response  | If called no. and called subaddress do not match the G4 subscriber no.  |
|             | Digital | N/A   | Not included          | G4 reception | If G4 Parameter Switch 01, bit 1 = 0.                                   |
|             |         |       |                       | No response  | If G4 Parameter Switch 01, bit 1 = 1.                                   |
|             | Digital | N/A   | Included              | G4 reception | If called no. and called subaddress match the G4 subscriber no.         |
|             |         |       |                       | No response  | If called no. and called subaddress do not match the G4 subscriber no.  |
|             | G3 Fax  | 3.1k  | G2/G3                 | Not included | G3 reception  |
| 3.1k        |         | G2/G3 | Included              | G3 reception | If called no. and called subaddress match the IG3 subscriber no.        |
|             |         |       |                       | No response  | If called no. and called subaddress do not match the IG3 subscriber no. |
| 3.1k        |         | N/A   | Not included          | G3 reception | If G4 Parameter Switch 01, bit 1 = 0.                                   |
|             |         |       |                       | No response  | If G4 Parameter Switch 01, bit 1 = 1.                                   |
| 3.1k        |         | N/A   | Included              | G3 reception | If called no. and called subaddress match the IG3 subscriber no.        |
|             |         |       |                       | No response  | If called no. and called subaddress do not match the IG3 subscriber no. |



| Tx Terminal | Setup          |        |                       | Response     | Condition   |
|-------------|----------------|--------|-----------------------|--------------|---|
|             | BC             | HLC    | Called No./ Called SA |              |   |
| G3 Fax      | Speech         | G2/G3  | Not included          | G3 reception |   |
|             | Speech         | G2/G3  | Included              | G3 reception | If called no. and called subaddress match the IG3 subscriber no.            |
|             |                |        |                       | No response  | If called no. and called subaddress do not match the IG3 subscriber no.     |
|             | Speech         | N/A    | Not included          | No response  | If G4 Internal Switch 14, bit 0 = 0, and G4 Parameter Switch 01, bit 1 = 0. |
|             |                |        |                       | G3 reception | If G4 Internal Switch 14, bit 0 = 1, and G4 Parameter Switch 01, bit 1 = 0  |
|             |                |        |                       | No response  | If G4 Internal Switch 14, bit 0 = 0, and G4 Parameter Switch 01, bit 1 = 1. |
|             |                |        |                       | No response  | If G4 Internal Switch 14, bit 0 = 1, and G4 Parameter Switch 01, bit 1 = 1. |
|             | Speech         | N/A    | Included              | G3 reception | If called no. and called subaddress match the IG3 subscriber no.            |
|             |                |        |                       | No response  | If called no. and called subaddress do not match the IG3 subscriber no.     |
|             | Tele-<br>phone | Speech | TEL                   | Not included | No response   |
| Speech      |                | TEL    | Included              | No response  |   |
| Speech      |                | N/A    | Not included          | No response  | If G4 Internal Switch 14, bit 0 = 0, and G4 Parameter Switch 01, bit 1 = 0. |
|             |                |        |                       | G3 reception | If G4 Internal Switch 14, bit 0 = 1, and G4 Parameter Switch 01, bit 1 = 0  |
|             |                |        |                       | No response  | If G4 Internal Switch 14, bit 0 = 0, and G4 Parameter Switch 01, bit 1 = 1. |
|             |                |        |                       | No response  | If G4 Internal Switch 14, bit 0 = 1, and G4 Parameter Switch 01, bit 1 = 1. |
| Speech      |                | N/A    | Included              | G3 reception | If called no. and called subaddress match the IG3 subscriber no.            |
|             |                |        |                       | No response  | If called no. and called subaddress do not match the IG3 subscriber no.     |

| Tx Terminal    | Setup |     |                       | Response     | Condition   |
|----------------|-------|-----|-----------------------|--------------|---|
|                | BC    | HLC | Called No./ Called SA |              |   |
| Tele-<br>phone | 3.1k  | TEL | Not included          | No response  |   |
|                | 3.1k  | TEL | Included              | No response  |   |
|                | 3.1k  | N/A | Not included          | G3 reception | If G4 Parameter Switch 01, bit 1 = 0.                                   |
|                |       |     |                       | No response  | If G4 Parameter Switch 01, bit 1 = 1.                                   |
|                | 3.1k  | N/A | Included              | G3 reception | If called no. and called subaddress match the IG3 subscriber no.        |
|                |       |     |                       | No response  | If called no. and called subaddress do not match the IG3 subscriber no. |